

MAN 4164047
Rev. B 03-2009



544946B
JR SODCUTTER 5.5HP HONDA 18"



OP / PARTS MANUAL

CALIFORNIA

Proposition 65 Warning

Diesel engine exhaust and some of its constituents are known to the State of California to cause cancer, birth defects and other reproductive harm.

⚠ WARNING

The engine exhaust from this product contains chemicals known to the State of California to cause cancer, birth defects or other reproductive harm.

CALIFORNIA

Proposition 65 Warning

Battery posts, terminals, wiring insulation, and related accessories contain lead and lead compounds, chemicals known to the State of California to cause cancer and birth defects or other reproductive harm.
WASH HANDS AFTER HANDLING.

IMPORTANT MESSAGE

Thank you for purchasing this Schiller Grounds Care, Inc. product. You have purchased a world class product, one of the best designed and built anywhere.

This machine comes with a Operation, Safety and Parts Manual. The useful life and good service you receive from this machine depends to a large extent on how well you read and understand this manual. Treat your machine properly, lubricate and adjust it as instructed, and it will give you many years of reliable service.

Your safe use of this Schiller Grounds Care, Inc. product is one of our prime design objectives. Many safety features are built in, but we also rely on your good sense and care to achieve accident-free operation. For best protection, study the manual thoroughly. Learn the proper operation of all controls. Observe all safety precautions. Follow all instructions and warnings completely. Do not remove or defeat any safety features. Make sure those who operate this machine are as well informed and careful in its use as you are.

See a Schiller Grounds Care, Inc. dealer for any service or parts needed. Schiller Grounds Care, Inc. service ensures that you continue to receive the best results possible from Schiller Grounds Care, Inc. products. You can trust Schiller Grounds Care, Inc. replacement parts because they are manufactured with the same high precision and quality as the original parts.

Schiller Grounds Care, Inc. designs and builds its equipment to serve many years in a safe and productive manner. For longest life, use this machine only as directed in the manual, keep it in good repair and follow safety warnings and instructions. You'll always be glad you did.

**Schiller Grounds Care, Inc.
One Bob Cat Lane
Johnson Creek, WI 53038-0469**

TABLE OF CONTENTS	PAGE
SAFETY	2-5
SET-UP	6
LABELS	7
CONTROLS	8, 9
OPERATION	10, 11
ADJUSTMENTS	12, 13
MAINTENANCE/SERVICE	14-21
STORAGE	22
TROUBLESHOOTING	23
SPECIFICATIONS	24
PARTS SECTION	25
DRIVE ASSEMBLY AND SIDE COVER	FIGURE 1 26, 27
GEAR CASE	FIGURE 2 28, 29
SIDE ARMS, PITMAN ARMS, AND HANDLES	FIGURE 3 30, 31
HANDLEBAR ASSEMBLY	FIGURE 4 32, 33

NOTICE !!!

Unauthorized modifications may present **extreme** safety hazards to operators and bystanders and could also result in product damage.

Schiller Grounds Care, Inc. strongly warns against, rejects and disclaims any modifications, add-on accessories or product alterations that are not designed, developed, tested and approved by Schiller Grounds Care, Inc. Engineering Department. Any Schiller Grounds Care, Inc. product that is altered, modified or changed in any manner not specifically authorized after original manufacture—including the addition of “after-market” accessories or component parts not specifically approved by Schiller Grounds Care, Inc. will result in the Schiller Grounds Care, Inc. Warranty being voided.

Any and all liability for personal injury and/or property damage caused by any unauthorized modifications, add-on accessories or products not approved by Schiller Grounds Care, Inc. will be considered the responsibility of the individual(s) or company designing and/or making such changes. Schiller Grounds Care, Inc. will vigorously pursue full indemnification and costs from any party responsible for such unauthorized post-manufacture modifications and/or accessories should personal injury and/or property damage result.



This symbol means:
ATTENTION!
BECOME ALERT!

Your safety and the safety of others is involved.

Signal word definitions:

The signal words below are used to identify levels of hazard seriousness. These words appear in this manual and on the safety labels attached to Schiller Grounds Care, Inc. machines. For your safety and the safety of others, read and follow the information given with these signal words and/or the symbol shown above.

DANGER

DANGER indicates a hazardous situation which, if not avoided, **WILL** result in death or serious injury.

WARNING

WARNING indicates a hazardous situation which, if not avoided, **COULD** result in death or serious injury.

CAUTION

CAUTION indicates a hazardous situation which, if not avoided, **COULD** result in minor or moderate injury. It may also be used to alert against unsafe practices or property damage.

CAUTION

CAUTION used without the safety alert symbol indicates a potentially hazardous situation which, if not avoided, **MAY** result in property damage.

Schiller Grounds Care, Inc.

One Bobcat Lane
Johnson Creek, WI 53038 U.S.A.
Phone: 920-699-2000
Fax: 920-699-3683

MODEL NUMBER

SERIAL NUMBER

MODEL NUMBER: This number appears on sales literature, technical manuals and price lists.

SERIAL NUMBER: This number appears only on your mower. It contains the model number followed consecutively by the serial number. Use this number when ordering parts or seeking warranty information.

JR SODCUTTER

PREPARING FOR SAFE OPERATION

Operator preparation and training

Read the Operation & Safety Manual

- If an operator or mechanic cannot read English, it is the owner's responsibility to explain this material to them. If any portion of this material is unclear, contact your factory representative for clarification.
- Become familiar with the safe operation of the equipment, operator controls and safety signs. Be prepared to stop the engine quickly in an emergency. Do not operate or allow another person to operate this machine if there are any questions about safety.
- All operators and mechanics should be trained. The owner is responsible for training the users.
- Wear appropriate clothing, including safety goggles or safety glasses with side shields when operating. Do not operate barefoot or wearing open sandals. Long hair, loose clothing or jewelry may get tangled in moving parts.
- Wear hearing protection.
- Wear safety glasses.
- Never allow underage children, unskilled or improperly trained people to operate this equipment. Local regulations can restrict the age of the operator.
- Keep warning labels and this operator's manual legible and intact. Replacement labels and manuals are available from the factory.
- Do not operate machine while under the influence of drugs or alcohol.
- The owner/user can prevent and is responsible for accidents or injuries occurring to themselves, other people or property.



SITE PREPARATION AND CIRCUMSTANCES

- Evaluate the terrain to determine how to safely perform the job. Only use accessories and attachments approved by the manufacturer.
- Clear the area to be cut of objects such as rocks, toys, wire or other debris that may be thrown or get tangled in the sod cutter.
- Be sure the area is clear of pets and people, especially young children. Never assume they will remain where you last saw them. Stop the machine if any enter the area.
- Cut sod only in daylight or in good artificial light.

MACHINE PREPARATION

- Check operator presence interlock system and brake operation. Adjust or repair any problems before using.
- Do not tamper with or defeat safety devices. Keep guards, shields and interlock safety devices in place and in proper working condition. They are for your protection.
- Keep all fasteners such as nuts, bolts and pins well secured.
- Visually inspect blade and bolts for wear or damage. Replace worn or damaged blades and bolts.
- Verify that machine and attachments, if any, are in good operating condition.
- Do not engage blade until ready to cut sod.

STORAGE SAFETY

- Stop the engine and allow to cool before storing.
- Drain the fuel tank outdoors only.
- Store fuel in an approved container in a cool, dry place.
- Keep the machine and fuel containers in a locked storage place to prevent tampering and to keep children from playing with them.
- Do not store the machine or fuel container near heating appliances with an open flame, such as a water heater, or an appliance with a pilot light.
- Keep gasoline storage area free of grass, leaves and excessive grease to reduce fire hazard.
- Clean grass and debris from cutting units, drives, mufflers and engine to help prevent fires.

OPERATING SAFELY

IN GENERAL

- Use extra care when loading or unloading the machine into a trailer or truck.
- Use caution when making turns and crossing roads and sidewalks. Stop blade when not cutting sod.
- Do not run the engine in an enclosed area where dangerous carbon monoxide fumes can collect.
- Never leave a machine unattended. Always turn off blade and stop engine when leaving the operator position. When leaving the machine be sure the wheel drive clutch is engaged.
- Use extreme caution when reversing or pulling machine towards you.

STARTING

- Start according to instructions in this manual or on the machine.
- Before attempting to start the engine, make sure the master clutch is disengaged.
- When starting the engine, make sure hands and feet are clear of the blade.
- Do not change engine governor settings or overspeed the engine. Operating the engine at excessive speed can increase the hazard of personal injury.



OPERATING ON SLOPES

USE EXTRA CARE WHEN WORKING ON SLOPES

- Do not operate on slopes if uneasy or uncertain. Ultimate responsibility for safe operation on slopes rests with the operator.
- Do not operate on steep slopes.
- Keep all movement on the slopes slow and gradual.
- Do not cut sod near drop-offs, ditches or embankments. The machine could suddenly turn over if a wheel runs over the edge or an edge caves in.
- Do not turn on slopes unless necessary, and then turn slowly and downhill when possible.
- Be sure of your footing on slopes.

INTERRUPTING OPERATION

- Before leaving the operator's position:
 - Park on level ground.
 - Disengage the master clutch.
 - Shut off the engine.
- Disengage the master clutch and wait until the blade stops moving then disengage the blade clutch:
 - when not cutting sod;
 - for transport;
 - when crossing surfaces other than grass.
- Stop the engine, disengage the master clutch and wait until the blade stops moving:
 - before refueling;
 - before making blade adjustment .
- Stop the engine, disengage the master clutch, and disconnect the spark plug wire(s):
 - before clearing blockages;
 - before checking, cleaning or working on the machine;
 - after striking a foreign object. Inspect the machine for damage and make repairs before restarting;
 - if the machine begins to vibrate abnormally: shut off machine immediately. Inspect and make repairs as needed before restarting;
 - except for repairs or adjustments as specifically noted, such as for carburetor adjustment, where the engine must be running. Keep hands and feet clear of moving parts in these circumstances.
- Allow the blade to come to a complete stop when stopping operation to clear blockages, unclog, inspect the machine, do maintenance or repair.
- Reduce the throttle setting during engine shut-down and, if the engine is provided with a shut-off valve, turn the fuel off at the conclusion of operation.

JR SODCUTTER

MAINTENANCE SAFETY

In general

- Maintain machine according to manufacturer's schedule and instructions for maximum safety and best results.
- Park machine on level ground.
- Never allow untrained personnel to service machine.
- Adjust or repair only after the engine has been stopped and the blade has stopped moving.
- Replace parts if worn, damaged or faulty. For best results, always replace with parts recommended by the manufacturer.
- Do not dismantle the machine without releasing or restraining forces which may cause parts to move suddenly.
- Provide adequate support, e.g. jack stands for lifted machine or parts if working beneath.
- Do not put hands or feet near or under rotating parts.
- Clean up spilled oil or fuel thoroughly.
- Replace faulty mufflers.
- To reduce fire hazards, keep the engine, muffler, and fuel storage area free of grass, leaves, debris buildup or grease.

MAINTENANCE AND ADJUSTMENTS

- Disconnect spark plug wire(s) before doing any maintenance.
- Particular care must be taken when adjusting the carburetor while the engine is running. Keep hands and feet clear. Shut off PTO.
- When working underneath lifted parts or machines, make sure adequate support is provided.
- Do not dismantle the machine without releasing or restraining forces which can cause parts to move suddenly.
- Keep all nuts, bolts and screws tight to be sure the equipment is in safe working condition.
- Replace worn or damaged parts for safety.

Blades



The sod cutter blade is sharp and can cut. Use extra caution when handling. Remove obstructions with care. Wrap the blade or wear gloves.



- Only replace blade. Never straighten or weld.
- Keep other persons away from blades.

Fuel



Gasoline and diesel fuels are flammable; gasoline vapors are explosive. Use extra care when handling.



- Store only in containers specifically designed for fuel.
- When refueling or checking fuel level:
 - Stop the engine and allow to cool;
 - Do not smoke;
 - Refuel outdoors only;
 - Use a funnel;
 - Do not overfill;
 - If fuel is spilled, do not attempt to start the engine until the spill is cleaned up and vapors have cleared.

Sparks from static electricity can start fires or cause explosions. Flowing fuel can generate static electricity. To prevent static electricity sparks:

- Keep containers electrically grounded. Do not fill containers in a vehicle or on a truck or trailer bed with a plastic liner. Fill containers on the ground away from the vehicle.
- When practical, remove gas powered equipment from the truck or trailer and refuel it on the ground. If equipment must be refueled on the truck or trailer, refuel from a portable container rather than a dispenser nozzle.
- Keep the dispenser nozzle in contact with the rim of the fuel tank or container opening until fueling is complete. Do not use a nozzle lock-open device.
- Replace caps on fuel cans and tanks securely.

SET-UP

JR SODCUTTER

SET-UP









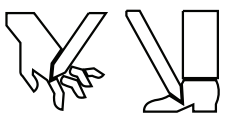

- To prevent injury, wear eye protection and stand clear when cutting banding. Banding is under tension and may snap back when cut.
- 1. Remove crate top, sides and plastic covering unit. Remove the banding attaching the Jr. Sodcutter to the pallet.
- 2. Roll the Jr. Sodcutter off the pallet. The unit can also be driven off the pallet, but first read the Safety, Controls, and Operation sections of this manual, then check the oil and add gas.
- 3. Dispose of pallet, crate, plastic and banding in a responsible manner.

JR SODCUTTER

<p>BLADE ADJUSTMENTS HARD SOIL OPERATION: 1. TIP BLADE FORWARD BY LOOSENING LOCKING LEVER (BLACK HANDLE RIGHT SIDE "H" FRAME). PUSH "H" FRAME FORWARD AS REQUIRED AND LOCK LEVER. DEPTH OF CUT: 1. LOOSEN UPPER RIGHT HAND LOCKING LEVER. TIP MACHINE FORWARD AND MOVE CENTER DEPTH CONTROL LEVER TO DESIRED DEPTH. LOCK IN POSITION BY ROTATING LOCKING LEVER CLOCKWISE. 2. LOOSEN DEPTH STOP LOCKING LEVER AT CENTER OF "H" FRAME. RAISE DEPTH STOP UNTIL IT CONTACTS DEPTH CONTROL LEVER AND LOCK IN PLACE. 3. ADJUST BLADE TO CUT SOD 3/4 TO 1 INCH THICK.</p> <p>TRANSPORTING MACHINE TO MOVE WITHOUT POWER: 1. DISENGAGE DRIVE WHEEL SHIFTER LEVER (ON FRONT-RIGHT SIDE OF MACHINE) BY ROTATING DOWNWARD. TO MOVE MACHINE UNDER POWER: 1. DISENGAGE CUTTING BLADE SHIFTER LEVER (ON FRONT-RIGHT SIDE OF MACHINE) BY ROTATING DOWNWARD. 2. ENGAGE DRIVE WHEEL SHIFTER LEVER (ON FRONT-RIGHT SIDE OF MACHINE) BY ROTATING UPWARD. 3. WITH ENGINE RUNNING, HOLD OPERATOR PRESENT LEVER AGAINST HANDLEBAR AND PUSH CLUTCH LEVER FORWARD TO THE ENGAGED POSITION.</p> <p>STARTING ENGINE 1. FILL FUEL TANK WITH REGULAR GASOLINE. 2. PULL CLUTCH LEVER BACK TO DISENGAGED POSITION. 3. SET THROTTLE TO 1/2 OPEN POSITION AND MOVE STOP SWITCH TO "ON" POSITION. 4. SET CHOKE AND START ENGINE.</p> <p>SOD CUTTING INSTRUCTIONS 1. MAKE REQUIRED BLADE ADJUSTMENTS AS STATED ABOVE. 2. START ENGINE PER INSTRUCTIONS ABOVE AND SET THROTTLE TO FULL SPEED. 3. ENGAGE DRIVE WHEELS BY ROTATING SHIFTER LEVER ON FRONT RIGHT SIDE OF MACHINE UPWARD. 4. ENGAGE CUTTING BLADE BY ROTATING SHIFTER LEVER ON REAR RIGHT SIDE OF MACHINE UPWARD. 5. WITH MACHINE TIPPED FORWARD ON FRONT BUMPER AND OPERATOR PRESENT LEVER HELD AGAINST HANDLEBAR, PUSH CLUTCH LEVER FORWARD. AT THE SAME TIME LOWER THE MACHINE SO BLADE ENTERS THE GROUND. 6. TO STOP MACHINE, PULL BACK FIRMLY ON CLUTCH LEVER. THIS APPLIES A BRAKE. 7. STOP ENGINE BY MOVING STOP SWITCH TO "OFF" POSITION.</p>	<p>OPERATING INSTRUCTIONS</p>
---	--------------------------------------

4124337

 <p>WARNING</p>

<p>-MOVING BLADE CAN CUT</p> <p>-KEEP HANDS AND FEET AWAY FROM MOVING PARTS</p> <p>-STOP ENGINE BEFORE SERVICING</p>
<p>4164033</p>

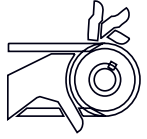
 ENGAGE	 <p>WARNING</p>	 DISENGAGE
 MASTER CLUTCH	<p>BEFORE STARTING OR SERVICING:</p> <p> Read and Understand the Operator's Manual and Labels.</p> <p>-Be sure the machine is in safe operating condition. -Make sure the Master Clutch is disengaged.</p> <p>BEFORE LEAVING MACHINE:</p> <p>-Disengage the Master Clutch. -Turn the engine switch to the OFF position.</p>	    
<p>4164032</p>		

 <p>WARNING</p>

<p>ROTATING PARTS CAN ENTANGLE, CUT AND CRUSH</p> <p>-Keep hands away from moving parts. -Do not operate without guards and shield in place. -Disconnect spark plug and read manual before performing any service or maintenance.</p>
<p>4163592</p>

4163592

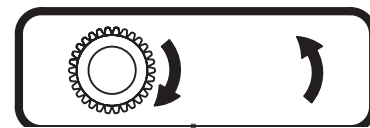

524485

Rotate lever counter clockwise to engage sodcutter blade drive.
 Rotate lever clockwise to disengage sodcutter blade drive.



524486

Rotate lever counter clockwise to engage wheel drive.
 Rotate lever clockwise to disengage wheel drive.

CONTROLS

JR SODCUTTER

MASTER CLUTCH CONTROL LEVER(A)

Engages / disengages drive belt. Applies brake to drive belt when pulled FIRMLY to rear.

THROTTLE CONTROL (B)

Controls engine speed.

ENGINE SWITCH

Move to "ON" position to start engine. Move to "OFF" position to stop the engine.

OPERATOR PRESENCE CONTROL (C)

With master clutch control engaged, engine will stop if operator presence lever is not depressed.

BLADE DEPTH CONTROL LEVER (D)

Raises or lowers cutting blade.

BLADE DEPTH CONTROL LOCKING LEVER (E)

Locking lever holds blade depth control in desired position.

BLADE ANGLE LOCKING LEVER (F)

Locks blades.

DEPTH STOP (G)

Allows resetting of blade depth to the previous cutting height.

HOUR METER - (H)

Shows how many hours that the engine has run. The far right digit is tenths of an hour (1/10).

-The wire from the hourmeter is wrapped around the spark plug wire four (4) turns and secured with Ty-raps.

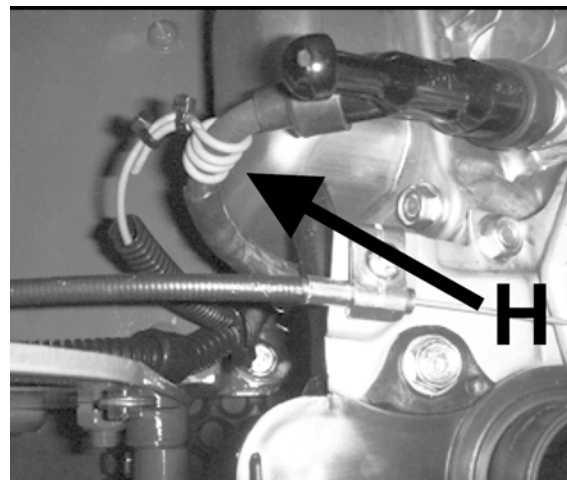
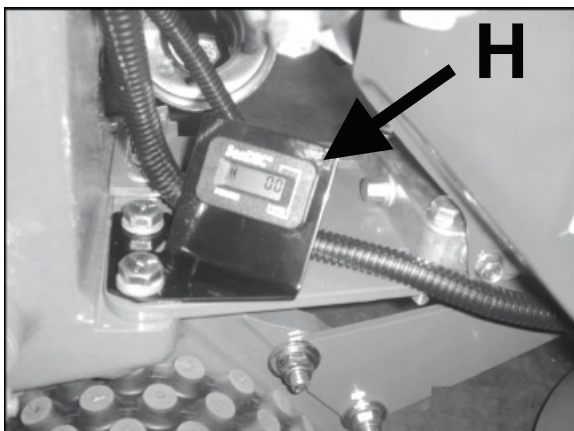
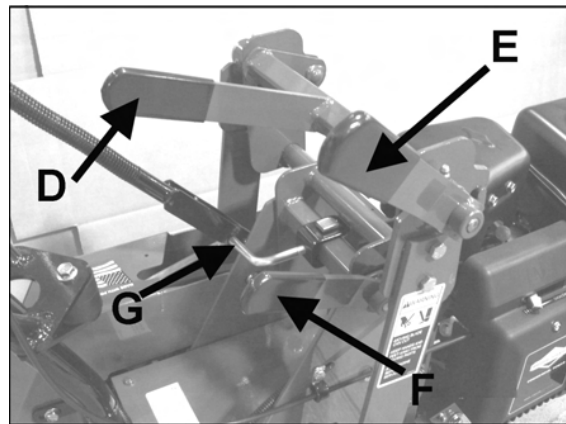
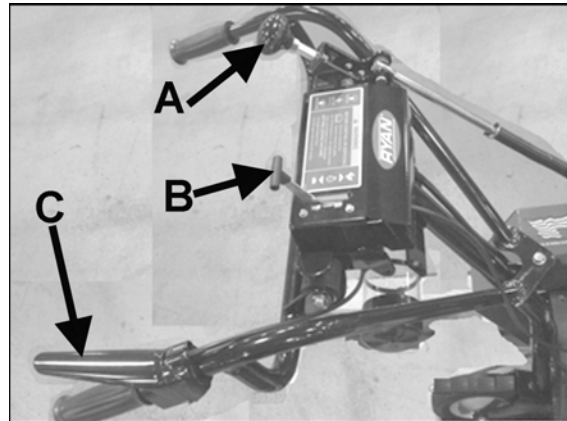

JR SODCUTTER

BLADE AND WHEEL SHIFTER HANDLES -(H & J)
Engage or disengage blade for cutting and gears for driving Sodcutter.

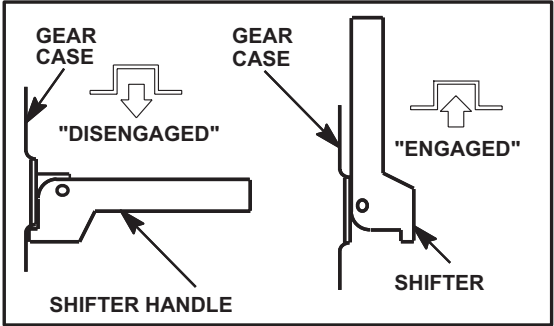
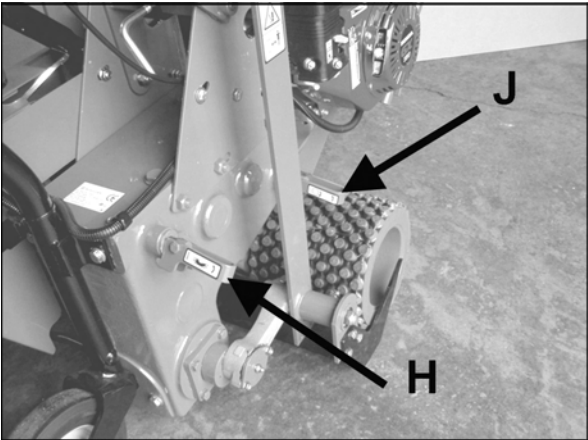

PRE-OPERATION CHECK LIST (OPERATOR'S RESPONSIBILITY)

- Review and follow all safety rules and safety decal instructions.
- Check that all safety decals are installed and in good condition. Replace if damaged.
- Check to make sure all shields and guards are properly installed and in good condition.
- Check that all hardware is properly installed and secured.
- Check to be sure engine is free of dirt and debris. Pay particular attention to the cooling fins, governor parts and muffler. Clean air intake screen. Check air cleaner; service is necessary.
- Inspect area. Remove stones or other hard objects that might cause damage.
- Check that there are no underground utilities in work area.
- Check all lubrication points and grease as instructed in manual.
- Perform a functional check of the safety interlock system each time you operate the unit. If it doesn't work, repair before using the machine.

BEFORE STARTING THE ENGINE

1. Be familiar with the controls, how each functions, and what each operates.
- 2.. Check engine oil level. Add oil if necessary, following the engine manufacturer's recommendations. Refer to engine manual supplied with machine.
3. Open the fuel valve under the fuel tank.
4. Fill the fuel tank with the amount and type of fuel recommended by the engine manufacturer.
5. **CHOKE:** For cold starts, set the throttle lever to the half-open position and move the choke to the ON position. For warm starts set the throttle to the half-open position and the choke to the OFF position.

OPERATOR PRESENCE INTERLOCK SYSTEM

To start the engine:

- The master clutch must be disengaged.

To operate the machine:

- The operator must hold down the operator presence lever or engaging the master clutch will kill the engine.

WARNING

Gasoline is extremely flammable and highly explosive under certain conditions. BE SURE to install fuel cap after refueling.



Fill fuel tank with good quality, clean, unleaded regular gasoline to the level recommended by the engine manufacturer.

TO CHECK OR ADD FUEL:

- Use a funnel to avoid spilling.
- Do it outdoors.
- Do not smoke.
- Stop the engine; allow to cool.
- Do not overfill.
- Clean up spilled fuel.

JR SODCUTTER

STARTING THE ENGINE

1. Move the engine switch to the "ON" position.
2. Pull the recoil starter to start the engine.
3. If the choke is ON when the engine starts, gradually back it off until the engine runs with no choke at all.

MOVING OF UNIT

To move unit without running blade:

1. Place blade shifter handle in "disengaged" position (handle will point straight out from unit) See **Figure 1**.
2. Set engine speed to slow.
3. Engage drive shifter handle.
4. Depress operator presence control.
5. Engage master clutch control lever.
6. Adjust throttle to desired walking speed.

To move unit **without running the engine**, put drive shifter handle and clutch control lever in the "disengaged" position. Push unit to move it.

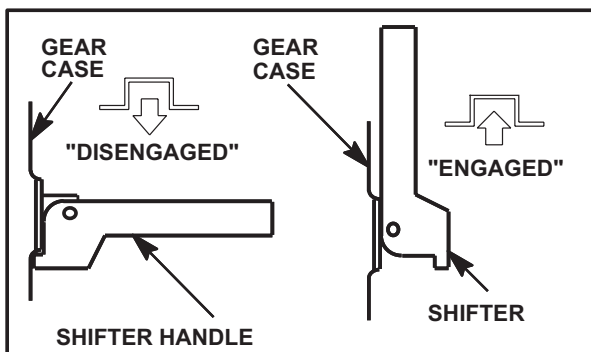

CUTTING SOD

WARNING: Underground utilities. Electrocution, explosion, service disruption risk.

Before beginning any work, check with the local authorities for underground utility location and depth. Do not operate where there is any risk of contacting underground utilities. Contacting buried utilities could result in a service outage. Contacting buried electrical wires could result in electrocution. Contacting a buried gas line could result in an explosion.

This precaution is especially important when using attachments such as the mole blade or trencher which operate at greater depths.

1. Move machine to the area where sod is to be cut. With the engine off and the master clutch disengaged, stand on the right side of the machine. Loosen the Blade Depth Control Locking Lever with your right hand, then use the handle bar to tip the machine forward and hold it with your left hand. Lower the Blade Depth Control Lever with your right hand until it hits the preset Depth Stop. Tighten the Locking Lever.
2. Start the engine, then engage the wheel drive and the blade drive with the Wheel Drive Shifter Lever and the Blade Drive Shifter Lever.
3. Adjust the throttle to full speed. With the machine tipped forward, engage the Master Clutch. The machine will start moving forward and the blade drive will operate. Lower the machine into the sod and cut for a short distance.
4. Stop the machine and check the sod thickness. Adjust the Depth Stop and blade if necessary. See Adjustment section.
5. Continue cutting. At the end of each pass lift up on the handle to raise the blade out of the sod and turn around for the next pass.

ADJUSTMENTS

JR SODCUTTER

DRIVE BELT ADJUSTMENT

Keep belt free of oil and dirt, and adjusted to proper tension at all times.

Belt tension is adjusted by loosening four (4) engine mounting bolts and shifting engine on the base.

Belt tension is correct when the distance between the roll pin and sleeve on the master clutch rod is 1" to 1 1/4" (25-30mm) when the master clutch is engaged.

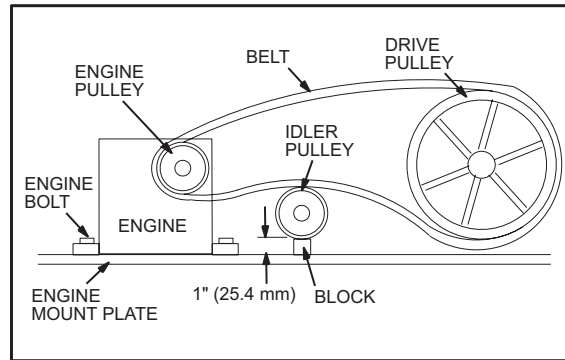

BRAKE BAND ADJUSTMENT

When adjusted properly:

- With the Master Clutch Control Lever engaged, the brake band is not braking the large drive pulley.
- When the Master Clutch Control Lever is disengaged, there will be some braking occurring on the large drive pulley.
- When the Master Clutch Control Lever is disengaged, and pulled back firmly, the brake will fully stop the large drive pulley.

1. For less braking, loosen the locknut, unscrew the adjusting screw, then retighten the locknut.
2. For more braking, loosen the locknut, turn the adjusting screw in, then retighten the locknut.

Start the machine, and check for proper operation. Readjust if necessary. IF the engine kills when engaging the Master clutch Control Lever, the brake may be set too tight.

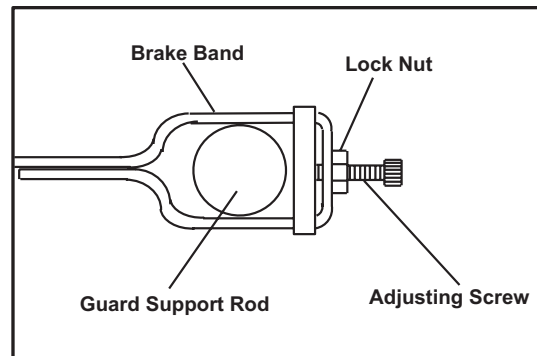

ADJUSTING DEPTH OF CUT

3/4" (20mm) is a good general starting depth of cut. Depth of cut can be varied from there depending on conditions and what you are trying to accomplish.

1. Make an initial depth setting. Park the machine on a hard surface. Loosen depth control locking lever E and power depth control lever D until the blade rests on the surface.
2. Loosen the depth gauge lock F and set top of depth gauge G 3/4" (20mm) below the top of the depth crossbar. Tighten the depth gauge lock to secure the depth gauge setting.
3. Use your left hand to tip the machine forward while lowering the depth control lever D until the depth control crossbar hit the Depth Stop G. Tighten the locking lever E to lock in the depth setting, make a trial run in turf. Check the depth of cut.

4. Re-adjust the depth gauge G and depth control lever D if necessary.

NOTE: Numbers on depth gauge do not necessarily represent thickness of sod being cut. The numbers are useful as a reference for making changes.

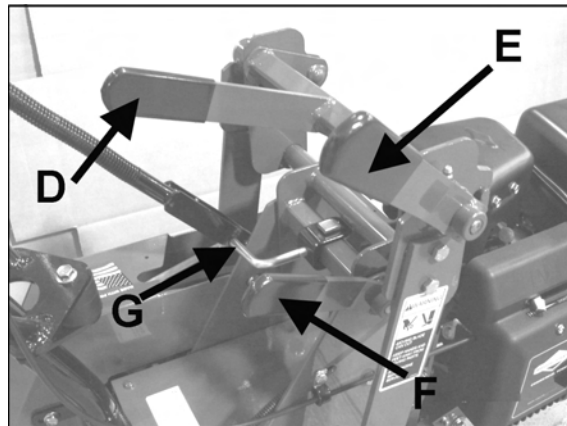

ADJUSTING OPERATOR PRESENCE CONTROL

1. To adjust operator presence cable, pull clutch control handle **A** rearward as far as possible.
2. Press operator presence handle (right handlebar) down as far as possible.
3. Adjust cable until the pivot arm **C** contacts the arm extending from the operator presence switch **B**.
4. Tighten cable clamp to secure cable. Check for proper operation.

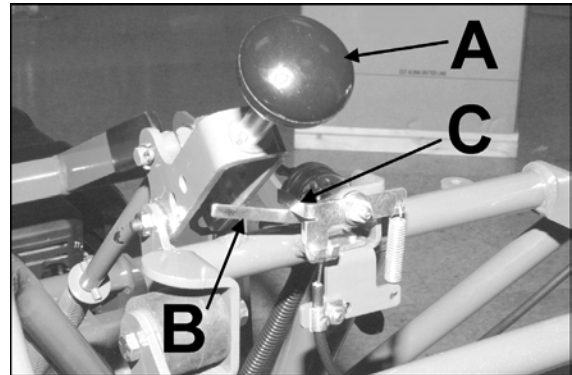

Cover removed for clarity

BLADE ANGLE (PITCH)

Under normal operating conditions, blade angle is minimal (blade bottom is flat). In extremely hard soil or when cutting with a dull blade, the blade may want to ride out of the ground. It may then help to adjust blade angle forward (see Adjusting Blade Angle below). A short trial run will indicate which is the best blade angle.

NOTE: Extreme blade angles put extra stress on the side arms. To reduce stress on the machine, operate with the flattest blade angle that gives satisfactory results.

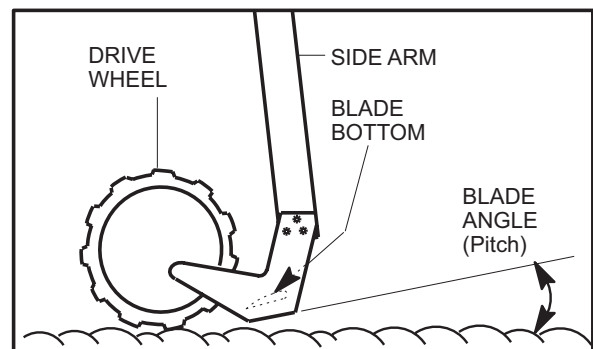

ADJUSTING BLADE ANGLE (PITCH)

1. Loosen blade angle control locking lever **F** and move H-frame forward or backward until blade is at desired angle of pitch.
2. Tighten blade angle control locking lever **F**.

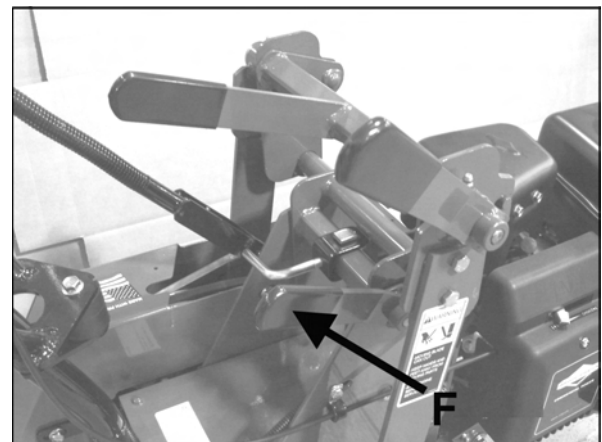

⚠ WARNING

When replacement parts are required, use genuine **Schiller Grounds Care, Inc.** parts or parts with equivalent characteristics, including type, strength and material. Failure to do so may result in product malfunction and possible injury to the operator and/or bystanders.

Carbon monoxide present in the exhaust is an odorless and deadly gas. Never start or run the engine inside where exhaust fumes can collect. Provide enough fresh air to keep fumes from getting too strong.

Replace any warning decal that becomes illegible immediately.

⚠ WARNING

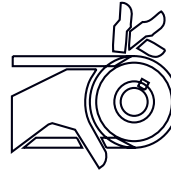

ROTATING PARTS CAN ENTANGLE, CUT AND CRUSH

- Keep hands away from moving parts.**
- Do not operate without guards and shield in place.**
- Disconnect spark plug and read manual before performing any service or maintenance.**

4163592

DAILY MAINTENANCE

Operator Presence System

For the engine to run, the Operator Presence Lever must be held when the Master Clutch Control is engaged.

To Check:

1. Start the engine and run at 1/2 throttle with the master clutch disengaged.
2. Engage the master clutch holding the Operator Presence Lever. Release the operator presence lever and the engine should stop.

Repair the machine before using if the Operator Presence System does not kill the engine.

Blades:

Check for damage. Replace any broken, cracked or otherwise damaged blades. Do not weld or straighten blades. Replace or sharpen dull blades. See Sharpening instructions.

Hardware:

Tighten any nuts and bolts that are found loose. Replace any broken or missing cotter pins. Repair any other problems before operating.

Engine:

See engine manual for change intervals and oil specifications. See engine manual for air cleaner service intervals and service procedure.

Lubrication:

The gear case is initially filled with 3 1/2 pints (1.7 L) of EP 140 Gear Lube. Do not add to this amount unless oil is changed or lost through leakage. Gear case drain plug **D**.

On all pressurized lubrication fittings use a good grade of Lithium Based lubricant.

The Jr. Sodcutter has 6 lubrication fittings. Lubricate pitman arms (1 each side) and side arms (1 each side) after every 4 hours of use.

Lubricate side arm pivots (1 each side - top of unit) after every 8 hours of use.

Check gear case lubricant level using dipstick **E** located on top of gear case. Check lube with dipstick sitting on threads, do not screw in.

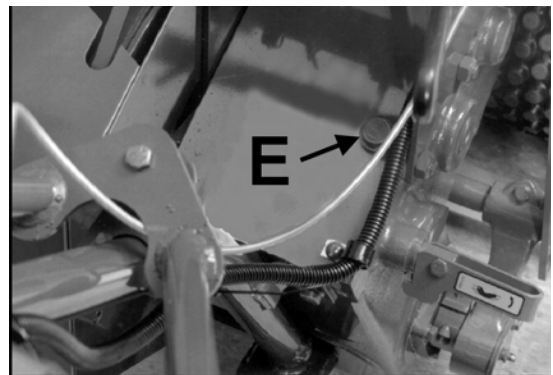
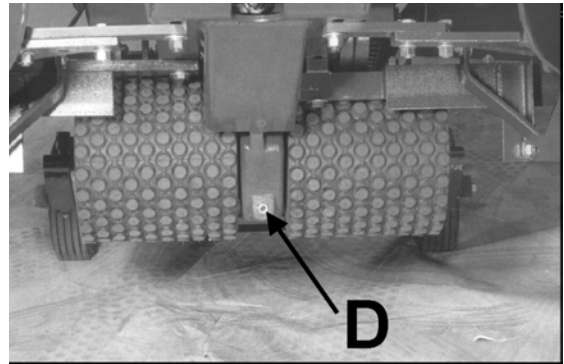

BLADE SHARPENING

1. Hand file bottom blade at 45° angle until no flat remains.
2. To keep cutting edge less than 1/16" (1.5mm) on 45° angle, grind milled surface back at 15° to less than 1/16" (1.5mm).
3. Hand file side blades at 45° until no flat remains.
4. To keep cutting edge less than 1/16" (1.5mm) on 45° angle, grind milled surface back at 15° to less than 1/16" (1.5mm).

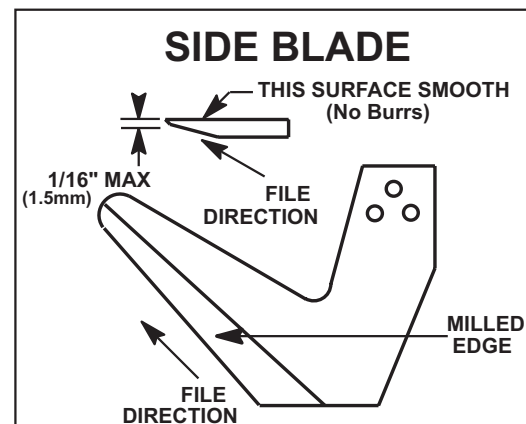
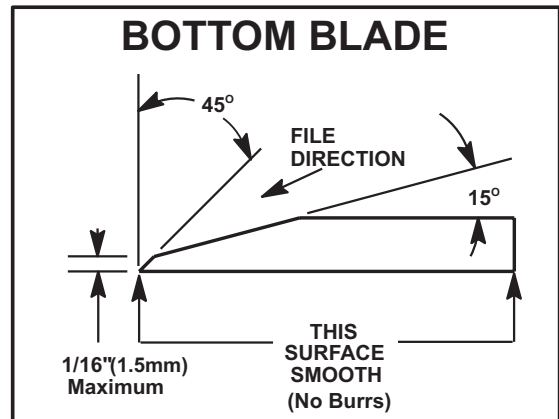

DRIVE BELT REPLACEMENT

1. Remove shield on left side of unit.
2. Remove nut securing brake band to clutch control rod.
3. Remove cotter pin on outside of guard support rod and move brake band over to nut on rod.
4. Loosen two bolts **A** securing belt guide to provide clearance when removing belt.
5. Install new belt in reverse procedure. Route the belt as shown.
6. Adjust belt and brake band. See Adjustment Section.

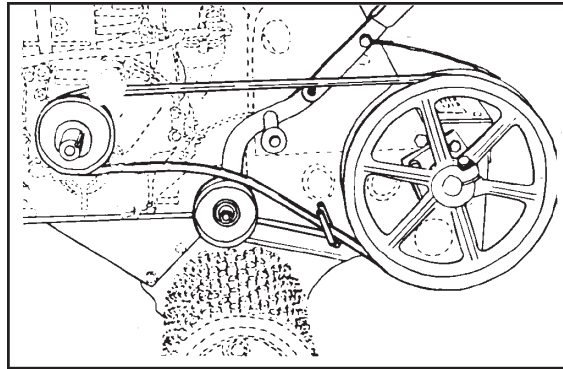
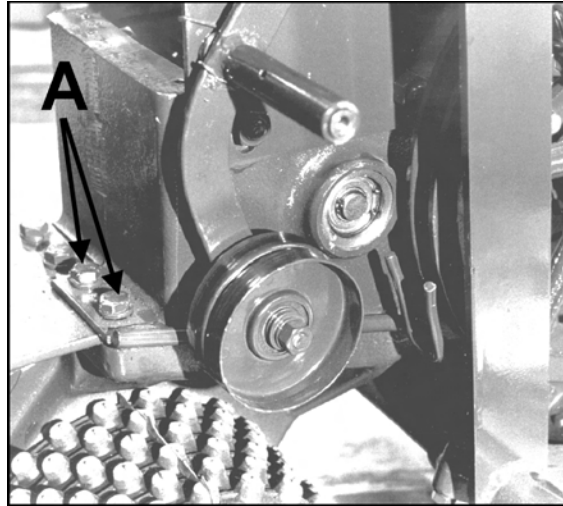

DRIVE CHAIN REMOVAL

1. Raise unit, place on adequate supports and remove belt guard.
2. Remove four (4) screws securing gear case cover.
3. Remove throttle cable from engine and lay behind cam case.
4. Remove dipstick from cover.
5. Remove screw, flat washer, nut and bushing from right lower side of "H" frame.
6. Using a screwdriver, lift gear case cover to break sealant bond and remove cover.
7. Drain oil out of front cavity on case, and turn drive wheels until master link is on top of sprocket.
8. Connect new chain to old with master link. Rotate drive wheels until new chain is pulled around. Remove old chain and connect new chain with a new master link.
9. Complete installation by reversing procedure. Clean mating surfaces on case and cover. Apply 3M Scotch Grip 847 or an equivalent adhesive to case cover before installation.

DRIVE WHEEL CHAIN SPROCKET SHAFT

1. Follow steps 1 thru 7 in drive chain removal section.
2. Remove master link and remove chain from top sprocket.
3. Remove both drive wheels and axle keys.
4. Remove seal in case and snap ring retaining bearing in case.
5. Install axle nut on end of shaft, opposite the side of snap ring previously removed.
6. Using a soft hammer (lead, brass, etc.), drive shaft out of case. Sprocket can now be removed by lifting up on chain.
7. Top sprocket and chain should be checked for wear and replaced if necessary.
8. Reassemble in reverse procedure using new seals and gaskets.

BRAKE BAND REPLACEMENT AND ADJUSTMENT

1. Remove belt guard.
2. Remove old brake band. Retain all hardware.
3. Install new brake band with the large loop and hardware at the lower mounting point (on guard support rod).
4. Loosen the lock nut and the adjustment screw on the new brake band. Engage the Clutch Control lever and tighten the adjustment screw until the brake band is pulled snug against the belt. (See Brake Band Adjustment, pg. 12) Tighten the lock nut on brake adjustment screw. Make a test run. Stop engine and re-adjust brake band if necessary.
5. Re-install belt guard using original hardware.

NOTE: Make sure that cotter pin does not interfere with drive belt.

Routine brake band adjustment is necessary as the band and belt wear.

If brake band is not correctly attached to clutch control link, idler arm will rotate backward away from belt and no drive will occur.

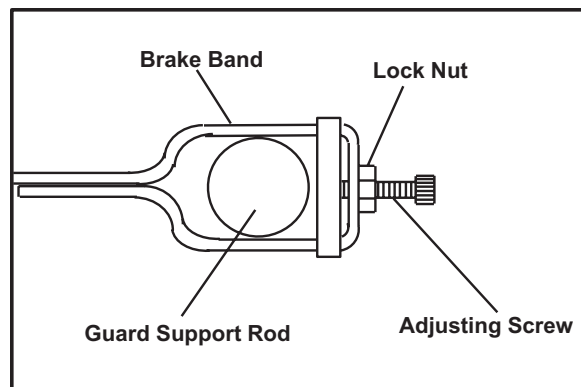

UPPER DRIVE SPROCKET & SHAFT

1. Follow steps 1 thru 6 in drive chain removal section.
2. Remove master link from chain. Chain does not need to be removed from lower sprocket.
3. Remove drive shifter assembly from gear case.
4. Remove blade and side arms from pivot brackets for easier access.
5. Remove plugs on both ends of shaft.
6. Remove snap rings **B** from left bearing.
7. Using a punch and soft hammer (lead, leather, etc.), drive shaft out left side of unit and remove large gear.
8. Using a bearing puller or slide hammer, remove bearing. Shaft is now removable through cam case cover opening.
9. Dog clutch half is removable from gear by removing snap ring.
10. Assemble in reverse procedure.
11. After installing blade shifter assembly, adjust dog clutch to provide .015" (0.39 mm) clearance between clutch faces, as shown.
12. Apply 3M Scotch Grip adhesive or an equivalent to gear case cover before installation.

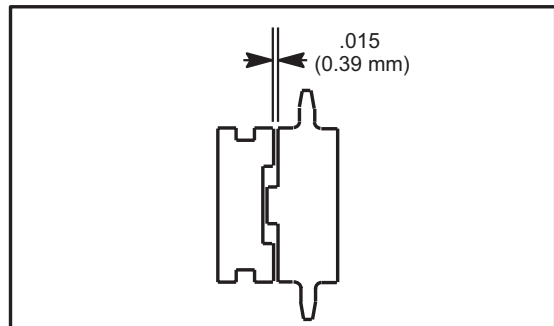
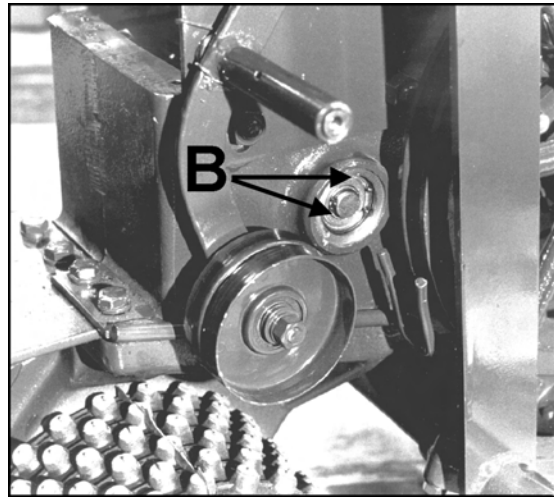

BLADE DRIVE CHAIN REPLACEMENT

NOTE: To prevent small components from falling down into oil cavities and causing damage to unit, cover opening with clean rags, cardboard, etc.

1. Follow steps 1 thru 6 in drive chain removal section.
2. Remove bottom screw on bearing cage to drain

oil from rear cavity.

3. Rotate pulley shaft until master link is to front of top sprocket. Remove master link.
4. Rotate blade drive shaft until chain is free.
5. Install new chain in reverse procedure. Use 3M Scotch Grip 847 or an equivalent adhesive on case cover and bearing retainer screw.

PULLEY SHAFT

1. Follow steps 1 thru 4 in belt replacement section and steps 2 thru 6 in drive chain removal section.
2. Remove blade from unit and remove left side arm.
3. Remove blade shifter assembly.
4. Turn pulley until master link is on top of sprocket. Remove chain from top sprocket.
5. Remove belt pulley and key.
6. Remove four (4) bearing cage screws and pull gears out left side of unit. Dog clutch and double sprocket will slide off as shaft is removed.
7. To remove gear and bearing, remove snap ring, slide gear off shaft and remove key. Remove bearing snap ring and remove bearing.
8. Assemble in reverse procedure. After blade shifter assembly is installed, adjust dog clutch to provide .015" (0.39 mm) clearance between clutch faces, as shown.
9. Apply 3M Scotch Grip 847 adhesive or equivalent to gear case cover before installation.

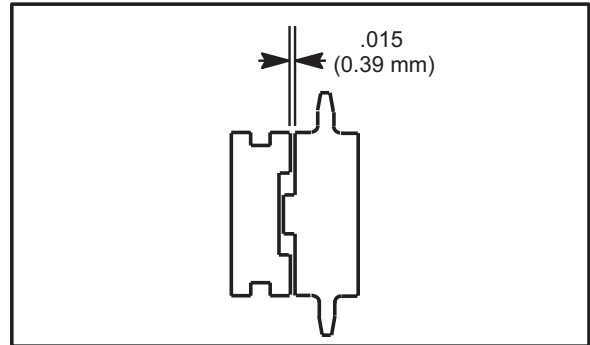
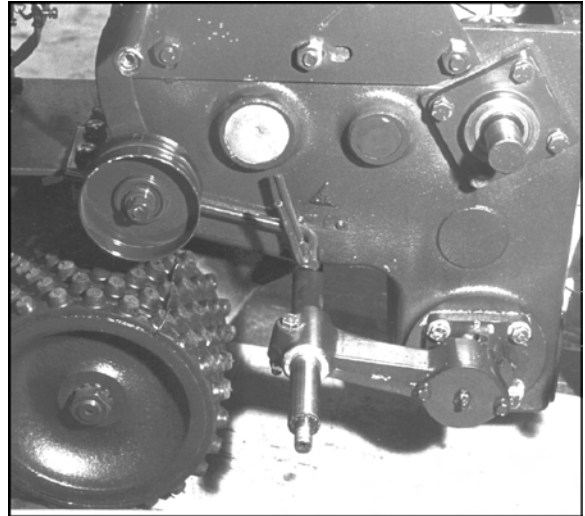

BLADE SPROCKET SHAFT

1. Follow steps 1 thru 6 in pulley shaft section.
2. Loosen clamp screw on left pitman arm **C** and remove from shaft.
3. Loosen clamp screw in eccentric assembly **D** and remove.
4. Remove two (2) top screws securing the other side arm assembly. Side arm, shaft and pitman arm, are now removable by pulling side arm out.
5. Remove eccentric and both bearing cages **E**. Put a pan under rear portion of case to catch oil from case cavity.
6. Push shaft to left of case, lift right end of shaft out of case with bearings and sprocket intact.
7. To remove sprocket, press bearing from shaft, and slide sprocket off.
8. Assemble in reverse procedure. After blade shifter assembly is installed, adjust dog clutch to provide .015" (0.39 mm) clearance between clutch faces, as shown.

NOTE: End play on shaft must not exceed .005 (.127 mm) clearance and should rotate freely when bearing cages are tightened. Shim as required to obtain correct clearance.

9. Apply 3M Scotch Grip 847 adhesive or equivalent to gear case cover before installation.

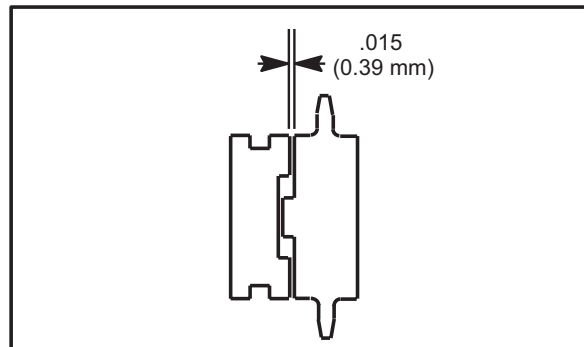
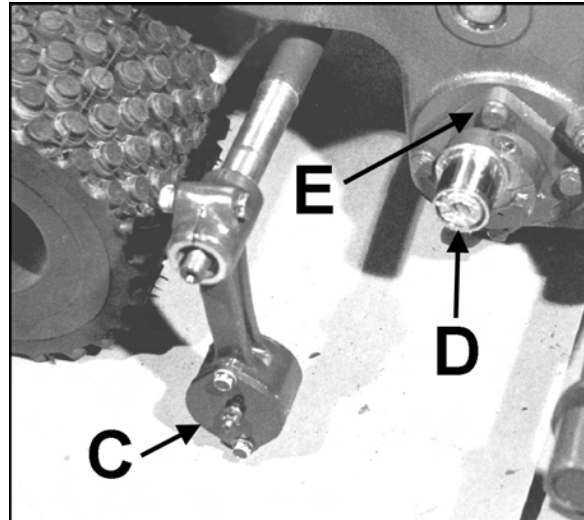

IDLER GEAR SHAFT

1. Remove belt guards.
2. Follow steps 2 thru 6 in drive chain removal section.
3. Remove plug from right side of unit.
4. Remove snap ring **C** from groove by small gear **B** to left end of shaft **A**.
5. Move small gear **B** to left side (from operators position) of case.
6. Move shaft **A** out right side of case until large gear clears shaft for removal.
7. Remove key from shaft and slide snap rings **C** off end of shaft.
8. Small gear **B** will slide off as shaft is removed from gear case.
9. Assemble in reverse procedure. Apply 3M Scotch Grip 847 adhesive or equivalent to gear case cover before installation.

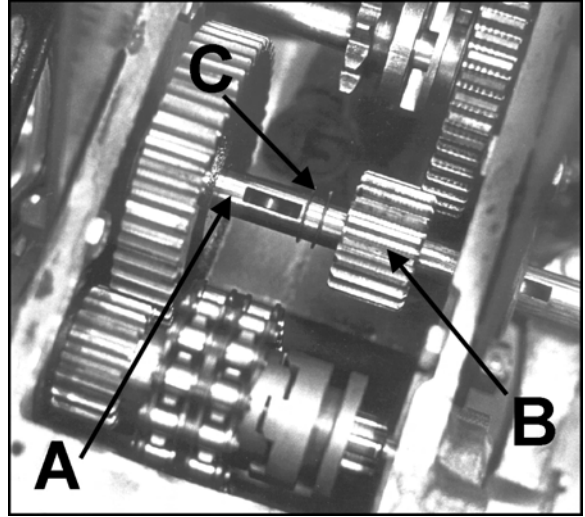

STORAGE INSTRUCTIONS

WARNING

To prevent possible explosion or ignition of vaporized fuel, do not store equipment with fuel in tank or carburetor in enclosure with open flame (for example, a furnace or water heater pilot light).

Daily Storage

1. Check engine oil level and air filter element daily.
2. Check oil level in gear case.
3. Close fuel valve at bottom of fuel tank.
4. Clean cutting blade (grass, dirt, etc.).

EXTENDED STORAGE

Before the equipment is put into storage for any period exceeding 30 days:

1. Drain all fuel from fuel tank and lines (use a hose or fuel line, routed from fuel tank shut-off to proper container).
2. Start engine and run until all fuel is used from the carburetor float bowl.
3. While engine is warm, drain the crankcase oil and refill with the proper weight of oil corresponding to the season when the equipment will next be used.
4. Remove the spark plug and squirt a small quantity of engine oil into the cylinder. Turn the engine over a few times to distribute the oil.
5. Lubricate all lubrication fittings.
6. Clean and oil cutting blade to prevent rust.

To put equipment into operation after an extended storage:

1. Fill fuel tank with clean fresh fuel.
2. Check crankcase oil level, and start engine.
3. Check fuel system for fuel leaks.

POSSIBLE PROBLEM	PROBABLE CAUSE	REMEDY
Blade will not stay in ground.	A. Bottom of blade is rounded off. B. Blade angle is not properly set.	A. Sharpen or replace blade. See page 15. B. Adjust blade angle. See page 13.
Root hair pinning on side or bottom of blade.	A. Some types of turf and soil make this a problem.	A. Keep the blade extra sharp and ground back at a low angle.
Belt jumps off.	A. Wrong type of belt construction. B. Too much slack when belt tightener is disengaged.	A. Use only the special Ryan factory belt. B. Slide engine forward and readjust control rod.
Locking levers not tight when pulled to limit of travel.	A. Thread wear on locking nut. B. Locking nut not properly adjusted.	A. Replace locking nut. B. Tighten locking nut on opposite end of tie rod.
Belt grabs in pulleys and unit creeps when clutch is not engaged.	A. Belt is old and frayed, or is not the type sent out with the unit. B. Rust or paint in pulley grooves. C. Engine set too far forward.	A. Replace with factory construction belt, designed for belt tightener clutches. B. Clean and polish pulleys. C. Move engine back.
Idler does not engage belt when clutch lever is moved forward.	A. Brake band is not attached to clutch link or is broken.	A. Reattach upper end of brake band to clutch link or replace brake band.

SPECIFICATIONS

Jr. Sodcutter

Models: 544946B.....Jr. Sodcutter - 12 inch		Cutting width:	
		544946B	18" (457 mm)
Engine		Blade pitch:	
Model.....	4 cycle 5.5 H.P. Honda Model GX160-K1QX2, GX160 OHV 9.9 cu. in. (163 cc)	Hand lever adjustment.....	variable 0° to 9°
Starter.....	Recoil	Blade speed:	
Governor.....	3500 RPM + 100 RPM, no load		1225 oscillations/min @ 3500 engine RPM
Clutch.....	spring loaded belt tightener type		
Vibration		Dimensions:	
Handlebar vibration level (in Z-axis)	2.94:1	Width.....	24" (600 mm)
		Length.....	49" (1244 mm)
Reduction		Height.....	33" (838 mm)
Engine to blade.....	2.94:1	Wheelbase.....	19" (483 mm)
Engine to drive wheels.....	55.8:1		
Wheels:		Weight:	
Drive.....	8" (203 mm) Dia. w/knobby tread vulcanized to hub	544944B.....	305 lbs. (138 Kg)
Rear.....	8 x 1.75 semi-pneumatic tires with pre-packed ball bearings	TOUCH -UP PAINT:	
			16OZ. (0.5L) Spray can, order P/N 65334
Drive:			
Engine to gear case.....	"A" section belt		
Gear case to drive shaft and blade drive.....	roller chain		
Gear case:			
Lubrication.....	EP140 Gear lube		
Capacity.....	3 1/2 Pints (1.7L)		

PARTS SECTION

DRIVE ASSEMBLY AND SIDE COVER

JR SOD CUTTER

FIGURE 1

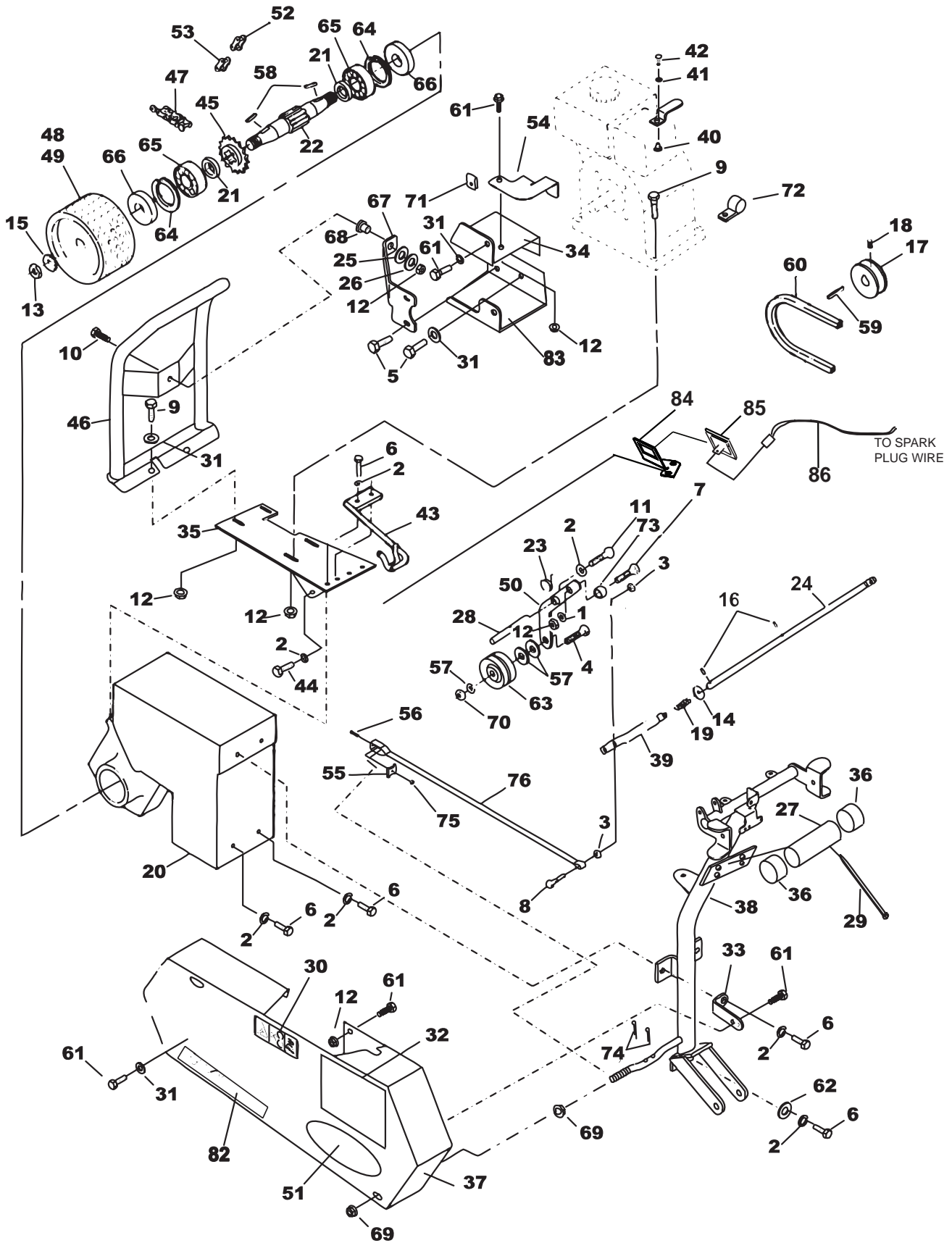

DRIVE ASSEMBLY AND SIDE COVER

JR SOD CUTTER

FIGURE 1

ITEM	PART NO.	DESCRIPTION	QTY	ITEM	PART NO.	DESCRIPTION	QTY
1-1	103867	WSHR, .31.69.06 YS FLT	1	1-49	547424.7	WHEEL AY 18" (USED ON 544845E & 544945A)	2
1-2	64006-05	LOCKWSHR-HELICAL 1/2	13				
1-3	F1002	NUT, JAM 1/4-20 UNC ZP	2				
1-4	64123-67	BLT-HEX 3/8-16X2	1	1-50	547428.7	IDLER ARM AY	1
1-5	64139-01	BLT-WLF 5/16-24X3/4	4	1-51	413976	LABEL-RYAN	1
1-6	64123-50	BOLT-HEX 3/8-16X1	12	1-52	548480	HALF LINK	A/R
1-7	64123-68	BOLT-HEX 5/16-18X1	5	1-53	4117675	LINK AY, #50 CONNECT	A/R
1-8	306418	SCRW, .25-20 1.125 YS HX	1	1-54	524610.7	BRACKET, BELT GUIDE	1
1-9	64139-23	BLT-WLF 5/16-18 X 1-3/4	4	1-55	524574	NUT, BRAKE BAND	1
1-10	548902	SCRW, .31-18 1.00 YS HSF	1	1-56	800888	SCRW, #10-32 1.00 BS NE (ITEMS 55, 56, 75 & 76 ARE AVAILABLE IN BRAKE BAND KIT 540274)	1
1-11	64123-15	BOLT-3/8-16X3/4 HEX	1				
1-12	64141-6	NUT, 5/16-18	4	1-57	306981	WSHR, .41 .81 .06 YS FLAT	6
1-13	307665	NUT, .75-16 YS HX JAM	2	1-58	64164-10	1/4X1/4X1-1/4 MACH KEY	2
1-14	64163-67	WASHER-.516X1X12GA	2	1-59	64164-11	KEY-3/16x3/16x1-1/4 SQ END	1
1-15	309799	LWSHR, .75 ZS SHKPRF EX	2	1-60	524582	BELT, V A SECT. 66" LONG	1
1-16	316938	PIN, SPIROL.188 1.000 PS	2	1-61	64139-06	BLT-WLH 5/16-18X5/8	6
1-17	517137	PULLEY, 4" DIA "A" SIZE	1	1-62	548164	WSHR, .41.81.07 YS FLT	1
1-18	64044-18	SCREW-SET 5/16-18 x 5/16	2	1-63	548942	PULLEY, PLAIN IDLER 3.25"	1
1-19	518535.7	SPRING	1	1-64	548952	RING, INTRNL RETAINING	2
1-20	520671.7	GEARCASE	1	1-65	548953	BRG, BALL 1.38 2.83.67	2
1-21	520722	SPACER	2	1-66	548954	SEAL, OIL 1.38 SHAFT	2
1-22	520723	SHAFT	1	1-67	524773.2	BRACE, GUARD	1
1-23	520785	SPRING	1	1-68	2702464	BUSHING, ISOLATION	1
1-24	521062.7	ROD	1	1-69	64141-13	NUT WLF 1/2-13	2
1-25	838496	WASHER, .25 1.00.125 FLAT	1	1-70	800698	NUT, 38-16 HX FLG CRWN	5
1-26	64163-29	WASHER-21/64 X 1 X 11GA	1	1-71	800889	NUT, .31-18 SPD J W/NUT	2
1-27	38541	TUBE, DOCUMENT 2.75OD	1	1-72	48228A	CABLE CLIP-INSULATED	3
1-28	521087	SHAFT	1	1-73	819337	BUSHING	1
1-29	65286-5A	TIE-CABLE 14 1\2	2	1-74	306956	COTTER PIN	2
1-30	4163592	DECAL, WARNING HANDS	1	1-75	64025-14	NUT-HEX #10-32	1
1-31	64163-55	WASHER .328X.75X14 GA	5	1-76	524573.7	BAND, BRAKE	1
1-32	4124337	DECAL, INFORMATION	1	1-77*	524775	FILTER, AIR CLEANER	1
1-33	520773.7	BRACKET	1	1-78*	524776	FILTER, AIR PRE-CLEANER	1
1-34	4163910.7	BRACKET, BELT GUARD, TOP	1	1-79*	540385	KIT, SPARK ARRESTOR (ITEMS 77-79 USED ON BRIGGS & STRATTON ENGINES ONLY)	1
1-35	524473.2	PLATE, ENGINE MOUNT	1				
1-36	38061A	CAP, VINYL	2	1-80*	524777	FILTER, AIR W/PRE-CLNR	1
1-37	4163353	S-GUARD ASSY	1	1-81*	540374	SPARK ARESTOR W/SCRW (ITEMS 80, 81 USED ON HONDA ENGINES ONLY)	1
1-38	540212.7	HANDLEBAR AY, MOUNT	1				
1-39	545247.7	CLEVIS AY	1				
1-40	831888	SWIVEL	1	1-82	4133034	LABEL-JR SOD CUTTER	1
1-41	831889	WASHER, SWIVEL	1	1-83	4163911.7	BRKT-BELT GUARD, BTM	1
1-42	831890	SCRW, SWIVEL THROTTLE (ITEMS 40-42 USED ON HONDA ENGINES ONLY)	1	1-84	4163415.7	MOUNT-HOUR METER	1
1-43	545380.2	GUIDE AY, BELT	1	1-85	4163411	METER-HOUR, INDUCTIVE	1
1-44	64123-87	BOLT-HEX 3/8-16X1-3/4	2	1-86	4163407	WIRE LEAD-HOUR METER	1
1-45	545626	SPROCKET AY	1				
1-46	540244.2	GUARD AY, FRONT	1				
1-47	547398	CHAIN AY, #50 RLR	1				
1-48	547408.7	WHEEL AY 12" (USED ON 544844E & 544944A)	2				

* NOT ILLUSTRATED

GEAR CASE

JR SOD CUTTER

FIGURE 2

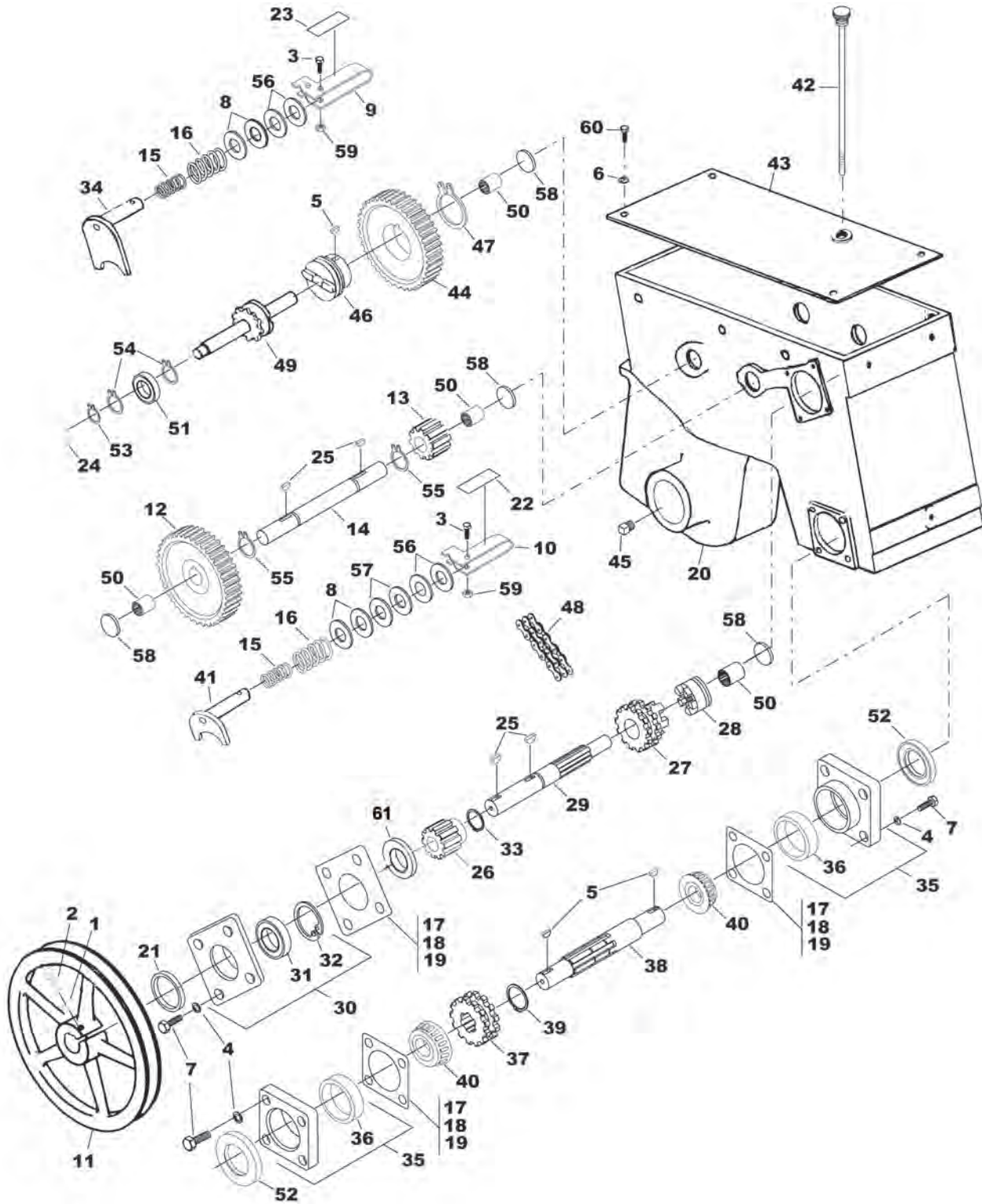

JR SOD CUTTER

FIGURE 2

ITEM	PART NO.	DESCRIPTION	QTY	ITEM	PART NO.	DESCRIPTION	QTY
2-1	64006-03	WSHR, 3/8 HELICAL LOCK	1	2-43	546037.7	COVER AY, GEAR CASE	1
2-2	64123-67	BLT-HEX 3/8-16X2	1	2-44	519404	GEAR,DRIVE	1
2-3	64123-80	BLT-HEX 1/4-20X1-1/4	2			(INCLUDES ITEMS 45-47)	
2-4	64006-02	LCKWSHER-HELICAL 5/16	12	2-45	548775	PLUG.25-18NPTF HS	1
2-5	64164-19	KEY WOODRUFF.19X.75 #9	3	2-46	516222	HUB	1
2-6	64006-01	LOCKWASHER-1/4 HELICAL	4	2-47	548329	RING,EXT LOCK 1.61ID.06T	1
2-7	64123-68	BOLT-HEX 5/16-18X1	12	2-48	546937	CHAIN, #50 DOUBLE	1
2-8	515891	SHIM,.64 1.25.010 YS	4	2-49	547427	SPROCKET & SHAFT AY	1
2-9	515896.7	HANDLE-WHEEL SHIFTER	1	2-50	548080	BRG.NDL.75 1.00.75	4
2-10	515897.7	HANDLE-BLADE SHIFTER	1	2-51	548096	BRG,BALL.59 1.38.43 "SS"	1
2-11	515901.7	PULLEY	1	2-52	548272	SEAL,OIL 1.00 SHAFT	2
2-12	516145	GEAR	1	2-53	548321	RING,EXT RET.56ID.037	1
2-13	516150	GEAR	1	2-54	548323	RING, INTRNL RETAINING	2
2-14	516156	SHAFT	1	2-55	548324	RING,EXT RET.691ID	2
2-15	516194	SPRING	2	2-56	548477	WASHER	4
2-16	516196	SPRING	2	2-57	548478	WSHR,.641 1.188.04 YS FLT	5
2-17	520238	SHIM .005 (.13MM)	A/R	2-58	548482	PLUG,EXPANSION 1.25 YS	4
2-18	520239	SHIM .010 (.25MM)	A/R	2-59	548597	LOCKNUT, UNI-TORQUE	2
2-19	520240	SHIM .020 (.51MM)	A/R	2-60	548726	SCRW,.25-20.75 YS RS	4
2-20	520671.7	GEARCASE	1	2-61	4139759	SPACER-GEAR	1
2-21	521941	SPACER,1.00 1.12.66	1				
2-22	524485	DECAL, BLADE SHIFTER	1				
2-23	524486	DECAL, WHEEL SHIFTER	1				
2-24	548931	PLUG,EXPANSION 1.75 YS	1				
2-25	64164-28	KEY-#808 WOODRUFF	4				
2-26	4139758	GEAR	1				
2-27	516162	SPROCKET, CLUTCH	1				
2-28	516172	CLUTCH	1				
2-29	516173	SHAFT	1				
2-30	544215	CAGE ASSY,BEARING	1				
		(INCLUDES ITEMS 31, 32)					
2-31	548131	BRG,BALL 1.00 2.00.50 "DA"	1				
2-32	548326	RING,INT RET 2.21OD.06	1				
2-33	548327	RING-LOCK	1				
2-34	544217.7	SHIFTER AY	1				
2-35	545050	CAGE AY,BEARING	1				
		(INCLUDES ITEM 36)					
2-36	814474	CUP,TPRD RLR BRG	1				
2-37	516160	SPROCKET	1				
2-38	521253	SHAFT-ECCENTRIC	1				
2-39	548336	LOCK RING (KC)	1				
2-40	814473	CONE,TPRD RLR BRG 1.00	2				
2-41	545710	SHAFT AY	1				
2-42	546033.7	DIPSTICK AY	1				

SIDE ARMS, PITMAN ARMS AND HANDLES

JR SOD CUTTER

FIGURE 3

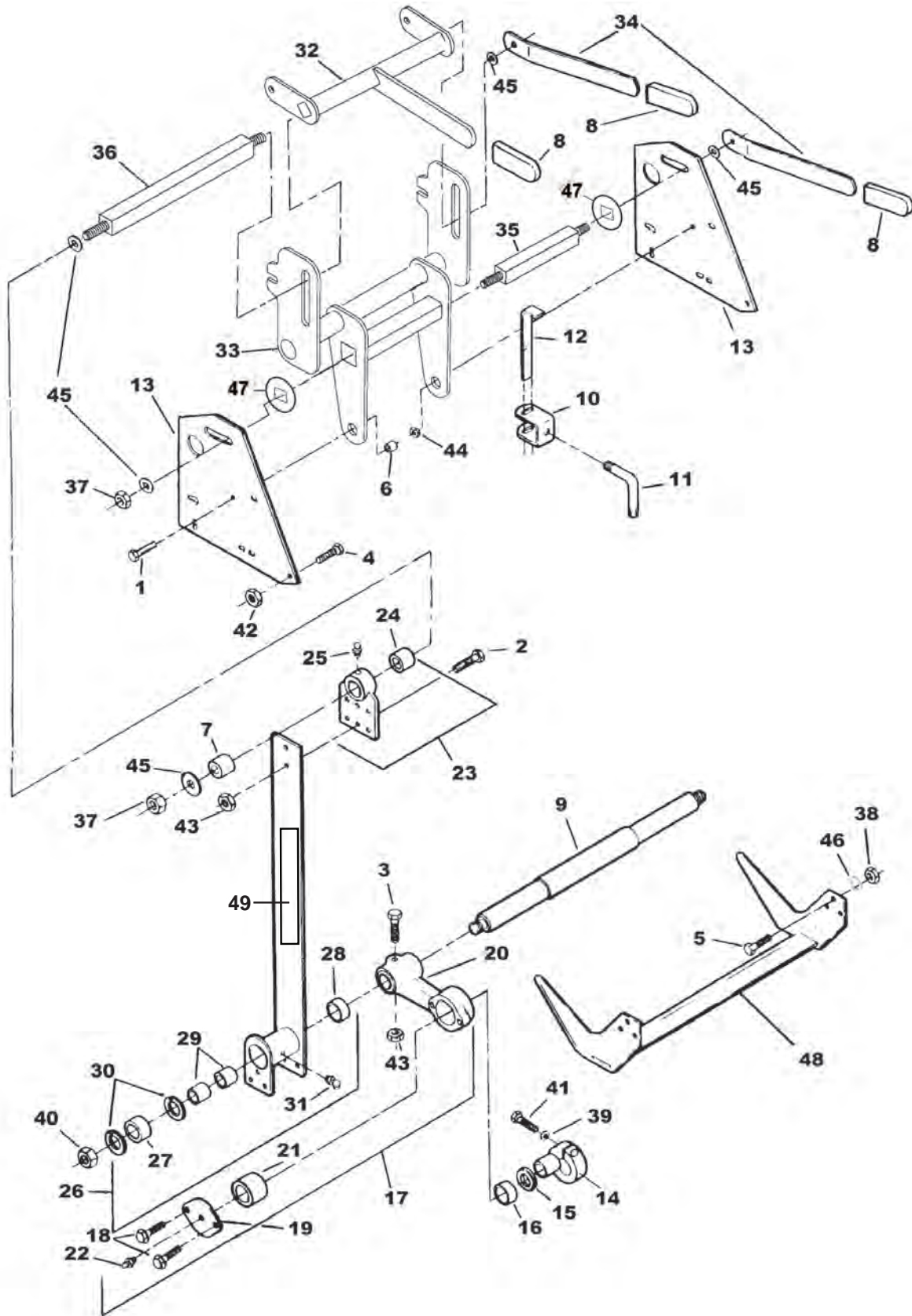

SIDE ARMS, PITMAN ARMS AND HANDLES

JR SOD CUTTER

FIGURE 3

ITEM	PART NO.	DESCRIPTION	QTY	ITEM	PART NO.	DESCRIPTION	QTY
3-1	64123-50	BOLT-HEX 3/8-16X1	2	3-39	548183	LWSHR,.31.09 HI-COLLAR	2
3-2	64123-68	BOLT-HEX 5/16-18X1	4	3-40	800198	NUT,.5-20 YS HX CRNLCK	2
3-3	64123-61	BLT-HEX 5/16-18X1-3/4	2	3-41	800513	SCRW-SCKT 5/16-18-1-1/4	2
3-4	328018	SCRW,.44-14 1.12 YS HX	6	3-42	548056	NUT,.44-14 YS HX UNITORQ	6
3-5	515011	SCRW,.31-24 1.00 ZS HX	6	3-43	64268-02	NUT-FL NYLNLCK 5/16-18	6
3-6	515729	BUSHING	2	3-44	64268-03	NUT-FL NYLNLCK 3/8-16	5
3-7	516067	BUSH,STL.515X.874X1.015	2	3-45	830287	WSHR,FLAT	6
3-8	4135868	COVER,HANDLE	3	3-46	64006-02	LOCKWSHR-HELICAL 5/16	6
3-9	521435.7	SHAFT, LOWER	1	3-47	4113281	WASHER, SPCL .531 SQ	2
3-10	521469.7	CLAMP, SADDLE	1	3-48	4132717.7	BLADE-SOD CUTTER, 18"	1
3-11	521470	HANDLE,LOCKING	1	3-49	4164033	LABEL-CHF VERT	2
3-12	521471	GAGE,DEPTH (PLATING)	1				
3-13	521472.2	BRACKET, PIVOT	2				
3-14	545436	ECCENTRIC AY	2				
		(INCLUDES ITEMS 15 & 16)					
3-15	521424	RING	1				
3-16	548814	RACE, INNER	1				
3-17	545437	ARM AY	2				
		(INCLUDES ITEMS 18-22)					
3-18	112050	TSCRW,.25-20.62 YS HW	2				
3-19	521425.2	PLATE - COVER	1				
3-20	521427.2	ARM, PITMAN	1				
3-21	521428	BRG,NDL 1.25 1.62 1.06	1				
3-22	85010-03	FITTING (KC)	1				
3-23	545443.2	BRACKET AY	2				
		(INCLUDES ITEMS 24, 25)					
3-24	521429	BRONZE BEARING	1				
3-25	548224	FITTING,GREASE 1/4 SPCL	1				
3-26	4153500	ARM AY, SIDE	2				
		(INCLUDES ITEMS 27-31, 49)					
3-27	521436	BALL BEARING	1				
3-28	521438	GREASE SEAL	1				
3-29	548138	BRG,NDL.88 1.12 1.00	2				
3-30	548340	LOCK RING (KC)	2				
3-31	35027N	FTG, GREASE 90D.25-28	1				
3-32	540209.2	LEVER AY	1				
3-33	540210.2	FRAME AY, H	1				
3-34	545449.2	HANDLE AY	2				
3-35	524549.2	ROD,TIE LOWER	1				
3-36	524550.2	ROD,TIE UPPER	1				
3-37	64151-7	LOCKNUT, 1/2-13 HEX	2				
3-38	64025-03	NUT-HEX 5/16-24	6				

HANDLEBAR ASSEMBLY JR SOD CUTTER

FIGURE 4

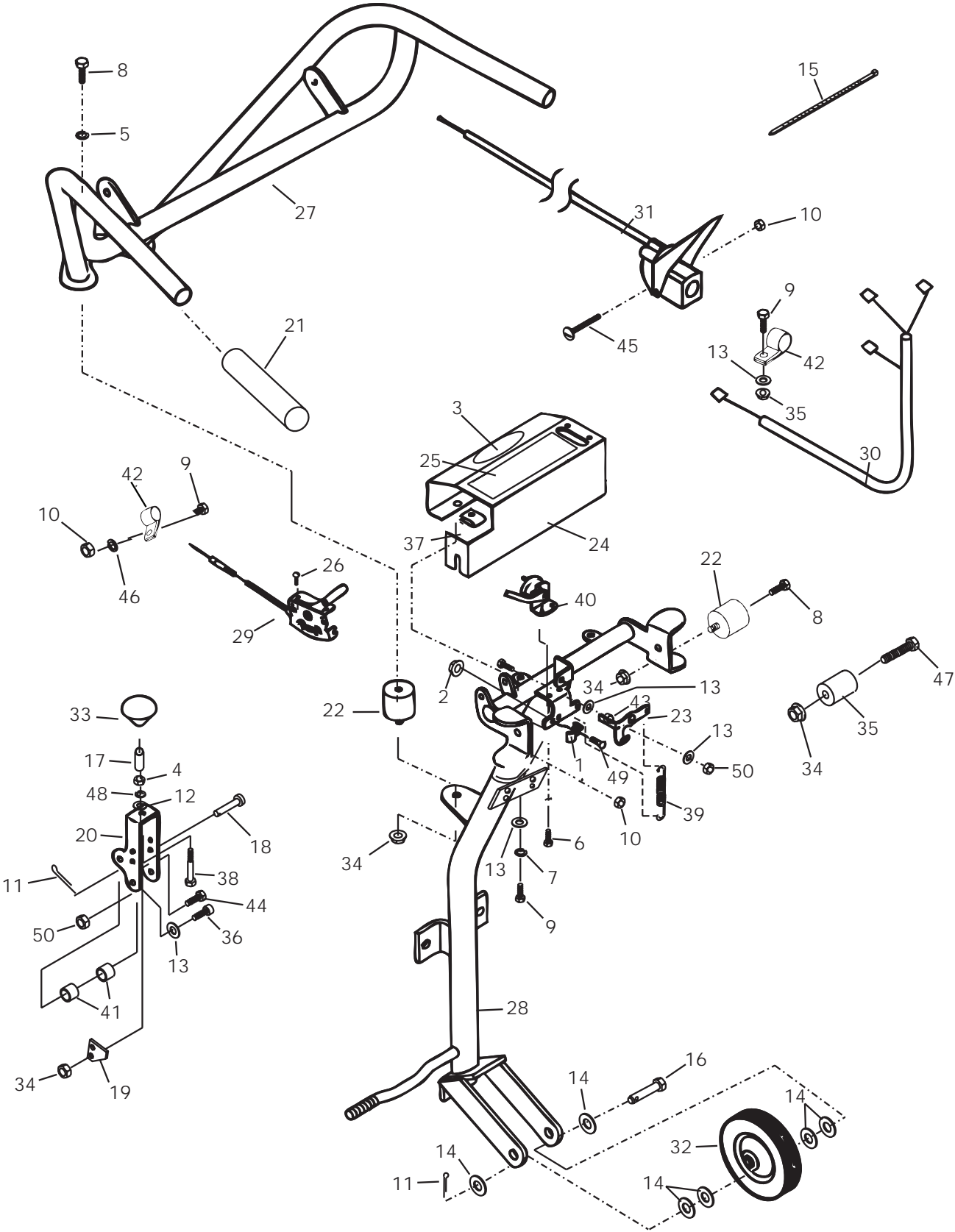

JR SOD CUTTER

FIGURE 4

ITEM	PART NO.	DESCRIPTION	QTY	ITEM	PART NO.	DESCRIPTION	QTY
4-1	111898	CLAMP,CABLE	1	4-45	800896	TSCRW,.190-24.75	1
4-2	64025-15	NUT-HEX #10-24 KEPS	1	4-46	64163-55	WASHER .328X.75X14 GA	1
4-3	4161125	LABEL-RYAN	1	4-47	306464	SCRW,.31-18 2.50 YS HX	3
4-4	64025-04	NUT-3/8-24 HEX	1			(OPTIONAL- USED TO ATTACH ITEM 35)	
4-5	64006-02	LCKWSHER-HELICAL 5/16	2	4-48	64163-61	WSHR .81X.406X16GA	1
4-6	64197-015	BLT-TDFM 10-32X1/2 TORX	2	4-49	64152-46	SCREW-SLT HH 10-24X1/2	1
4-7	64006-01	LCKWSHER-1/4 HELICAL	2	4-50	64229-01	NUT-NYLON 1/4-20	3
4-8	548901	SCRW,.31-18.50 YS HSF G5	3				
4-9	64123-89	BOLT-HEX 1/4-20X3/4	8				
4-10	64151-17	LOCKNUT, HEX	4				
4-11	64140-1	COTTER PIN-1/8X1	3				
4-12	64006-03	WSHR, 3/8 HELICAL LOCK	1				
4-13	64163-03	WSHR-.256IDX62ODX18GA.	6				
4-14	64163-67	WASHER-.516X1X12GA	6				
4-15	65286-4A	TIE,CABLE 11-5/8 BLACK	3				
4-16	515726	SHAFT	1				
4-17	516544	BUSHING (PLATING)	1				
4-18	516634	PIN,CLEVIS.38 1.75 YS	1				
4-19	4135035.7	FLAT-SWITCH ACTIVATION	1				
4-20	522585.7	HANDLE,CONTROL	1				
4-21	522727	GRIP,HANDLE	2				
4-22	829148	MOUNT,ISOLATION	3				
4-23	524472	ARM, PIVOT (PLATING)	1				
4-24	540347	COVER-W LABELS	1				
4-25	4164032	LABEL-CONTROL PANEL1					
4-26	64152-18	TSCRW,#8-18.50 SLF-DRL	2				
4-27	540211.7	HANDLEBAR AY	1				
4-28	540212.7	HANDLEBAR AY, MOUNT	1				
4-29	540326	CONTROL AY,THROTTLE	1				
4-30	540229	WIRE AY	1				
4-31	540232	CONTROL AY, KILL SWITCH	1				
4-32	4124195	WHEEL AY, 8X1.25 SOLID	1				
4-33	548171	KNOB	1				
4-34	64141-6	NUT, 5/16-18	5				
4-35	524551	SPACER	3				
		(OPTIONAL - MAY BE USED IN PLACE OF ITEM 22 WITH ITEM 47)					
4-36	800492	CAPSCREW,HEX (KC)	1				
4-37	800495	NUT,.25-20 BS SPD "U"	2				
4-38	800883	SCRW,.38-24 2.25 YS HX	1				
4-39	805421	SPRING,EXTENSION	1				
4-40	806800	SWITCH,STOP LIGHT	1				
4-41	524577	BUSHING, .328X.63X.41	2				
4-42	48228A	CABLE CLIP-INSULATED	4				
4-43	814585	BUSHING	1				
4-44	64139-06	BOLT-WLH 5/16-18X5/8	2				