



**936600**

**48" HYDRO MID-FX541 KAW FLOATING SIDE DISCHARGE**

**936601**

**52" HYDRO MID-FX600 KAW FLOATING SIDE DISCHARGE**

**936602**

**61" HYDRO MID-FX651 KAW FLOATING SIDE DISCHARGE**

**MAN 4169432**  
Rev. A 01-2014



---

# **OPERATOR'S / PARTS MANUAL**

**CALIFORNIA**

**Proposition 65 Warning**

Diesel engine exhaust and some of its constituents are known to the State of California to cause cancer, birth defects and other reproductive harm.

**⚠ WARNING**

The engine exhaust from this product contains chemicals known to the State of California to cause cancer, birth defects or other reproductive harm.

**Californie Proposition 65 Avertissement**

Les échappements des moteurs diesel et certains de leurs composés sont reconnus par l'Etat de Californie pour être cancérigènes, provoquer des défauts congénitaux et d'autres dangers en matière de reproduction.

**⚠ AVERTISSEMENT**

L'émission du moteur de ce matériel contient des produits chimiques que l'Etat de Californie considère être cancérigènes, provoquer des défauts congénitaux et d'autres dangers en matière de reproduction.

**California Advertencia de la Proposicion 65**

El estado de California hace saber que los gases de escape de los motores diesel y algunos de sus componentes producen cáncer, defectos de nacimiento y otros daños en el proceso de reproducción humana.

**⚠ ADVERTENCIA**

El estado de California hace saber que los gases de escape de este producto contienen productos químicos que producen cáncer, defectos de nacimiento y otros daños en el proceso de reproducción humana.

**CALIFORNIA**

**Proposition 65 Warning**

Battery posts, terminals, wiring insulation, and related accessories contain lead and lead compounds, chemicals known to the State of California to cause cancer and birth defects or other reproductive harm.

**WASH HANDS AFTER HANDLING.**

## IMPORTANT MESSAGE

Thank you for purchasing this Schiller Grounds Care, Inc. product. You have purchased a world class mowing product, one of the best designed and built anywhere.

This machine comes with an Operation and Safety Manual and a separate Setup, Parts and Maintenance Manual. The useful life and good service you receive from this machine depends to a large extent on how well you read and understand these manuals. Treat your machine properly, lubricate and adjust it as instructed, and it will give you many years of reliable service.

Your safe use of this Schiller Grounds Care, Inc. product is one of our prime design objectives. Many safety features are built in, but we also rely on your good sense and care to achieve accident-free operation. For best protection, study the manuals thoroughly. Learn the proper operation of all controls. Observe all safety precautions. Follow all instructions and warnings completely. Do not remove or defeat any safety features. Make sure those who operate this machine are as well informed and careful in its use as you are.

See a Schiller Grounds Care, Inc. dealer for any service or parts needed. Schiller Grounds Care, Inc. service ensures that you continue to receive the best results possible from Schiller Grounds Care, Inc. products. You can trust Schiller Grounds Care, Inc. replacement parts because they are manufactured with the same high precision and quality as the original parts.

Schiller Grounds Care, Inc. designs and builds its equipment to serve many years in a safe and productive manner. For longest life, use this machine only as directed in the manuals, keep it in good repair and follow safety warnings and instructions. You'll always be glad you did.

**Schiller Grounds Care, Inc.**  
**One Bob Cat Lane**  
**Johnson Creek, WI 53038-0469**

TABLE OF CONTENTS .....	PAGE
SAFETY.....	2-7
LABELS.....	8-10
CONTROLS.....	11, 12
OPERATION.....	13-15
LUBRICATION.....	16
MAINTENANCE .....	17-19
MAINTENANCE CHART/RECORD .....	20, 21
HEIGHT OF CUT.....	22-24
BELT REPLACEMENT .....	25
ADJUSTMENTS .....	26-29
SPECIFICATIONS.....	30-32
PARTS SECTION.....	33
UPPER ENGINE DECK ASSY .....	FIGURE 1 .....34, 35
LOWER ENGINE DECK ASSY/CLUTCH.....	FIGURE 2 .....36, 37
DRIVE WHEELS / CUTTERDECK MOUNTING .....	FIGURE 3 .....38, 39
PARKING BRAKE / DOCUMENT TUBE .....	FIGURE 4 .....40, 41
UPPER HANDLE.....	FIGURE 5 .....42, 43
TRACTION CONTROLS .....	FIGURE 6 .....44, 45
ELECTRIC START BATTERY .....	FIGURE 7 .....46, 47
HYDRAULICS .....	FIGURE 8 .....48, 49
CASTER ASSY.....	FIGURE 9 .....50, 51
HEIGHT OF CUT ASSY .....	FIGURE 10 .....52, 53
POWER UNIT DECALS .....	FIGURE 11 .....54, 55
WIRING SCHEMATIC-ELECTRIC START .....	FIGURE 12 .....56, 57
WIRE DIAGRAM-ELECTRIC START .....	FIGURE 13 .....58, 59
HYDROGEAR PUMP .....	FIGURE 14 .....60, 61
MOUNTING-48" FIXED DECK.....	FIGURE 15 .....62, 63
MOUNTING-52" FIXED DECK.....	FIGURE 16 .....64, 65
MOUNTING-61" FIXED DECK.....	FIGURE 17 .....66, 67
CHUTE, BAFFLES, EDGES.....	FIGURE 18 .....68, 69

**NOTICE !!!**

Unauthorized modifications may present **extreme** safety hazards to operators and bystanders and could also result in product damage.

Schiller Grounds Care, Inc. strongly warns against, rejects and disclaims any modifications, add-on accessories or product alterations that are not designed, developed, tested and approved by Schiller Grounds Care, Inc. Engineering Department. Any Schiller Grounds Care, Inc. product that is altered, modified or changed in any manner not specifically authorized after original manufacture—including the addition of “after-market” accessories or component parts not specifically approved by Schiller Grounds Care, Inc.—will result in the Schiller Grounds Care, Inc. Warranty being voided.

Any and all liability for personal injury and/or property damage caused by any unauthorized modifications, add-on accessories or products not approved by Schiller Grounds Care, Inc. will be considered the responsibility of the individual(s) or company designing and/or making such changes. Schiller Grounds Care, Inc. will vigorously pursue full indemnification and costs from any party responsible for such unauthorized post-manufacture modifications and/or accessories should personal injury and/or property damage result.



This symbol means:  
**ATTENTION!**  
**BECOME ALERT!**

Your safety and the safety of others is involved.

**Signal word definitions:**

The signal words below are used to identify levels of hazard seriousness. These words appear in this manual and on the safety labels attached to Schiller Grounds Care, Inc. machines. For your safety and the safety of others, read and follow the information given with these signal words and/or the symbol shown above.

**⚠ DANGER**

**DANGER** indicates an imminently hazardous situation which, if not avoided, **WILL** result in death or serious injury.

**⚠ WARNING**

**WARNING** indicates a potentially hazardous situation which, if not avoided, **COULD** result in death or serious injury.

**⚠ CAUTION**

**CAUTION** indicates a potentially hazardous situation which, if not avoided, **MAY** result in minor or moderate injury. It may also be used to alert against unsafe practices or property damage.

**CAUTION**

**CAUTION** used without the safety alert symbol indicates a potentially hazardous situation which, if not avoided, **MAY** result in property damage.

***Schiller Grounds Care, Inc.***

One Bobcat Lane  
Johnson Creek, WI 53038 U.S.A  
Phone: 920-699-2000  
Fax: 920-699-3683

**MODEL NUMBER**

**SERIAL NUMBER**

**MODEL NUMBER:** This number appears on sales literature, technical manuals and price lists.

**SERIAL NUMBER:** This number appears only on your mower. It contains the model number followed consecutively by the serial number. Use this number when ordering parts or seeking warranty information.

## PREPARING FOR SAFE OPERATION

### Operator preparation and training

#### Read the Operation & Safety Manual

Read the operator's manual carefully. All rotary grass cutters are potentially dangerous. No person should operate the machine unless they are familiar with the controls and the proper use of the machine.



- If an operator or mechanic cannot read English, it is the owner's responsibility to explain this material to them. If any portion of this material is unclear, contact your factory representative for clarification.
- Become familiar with the safe operation of the equipment, operator controls and safety signs. Know how to stop the engine and attachments quickly in an emergency. Do not operate or allow another person to operate this machine if there are any questions about safety.
- All operators and mechanics should be trained. The owner is responsible for training the users.
- Wear appropriate clothing, including long trousers and safety goggles or safety glasses with side shields when operating mower. Do not operate barefoot or wearing open sandals. Long hair, loose clothing or jewelry may get tangled in moving parts.
- Wear hearing protection.
- Never allow underage children, unskilled or improperly trained people operate this equipment. Local regulations can restrict the age of the operator.
- Data indicates that those operators age 60 years and above are involved in a large percentage of riding mower-related injuries. Those operators should evaluate their ability to operate the riding mower safely enough to protect themselves and others from injury.
- Do not carry passengers, especially small children. They may fall off and be seriously injured.
- Keep warning labels and this operator's manual legible and intact. Replacement labels and manuals are available from the factory.



- Do not operate machine while under the influence of drugs or alcohol.
- The owner/user can prevent and is responsible for accidents or injuries occurring to themselves, other people or property.

### Site preparation and circumstances

- Evaluate the terrain to determine what accessories and attachments are needed to properly and safely perform the job. Only use accessories and attachments approved by the manufacturer.
- Clear the area to be mowed of objects such as rocks, toys, wire or other debris that may be picked up or thrown by the mower.
- Be sure the area is clear of pets and people, especially young children. Never assume they will remain where you last saw them. Stop the machine if any enter the area.
- Mow only in daylight or in good artificial light.
- Do not mow wet grass as tires may lose traction.

## Machine preparation

### Before using machine for the first time, check engine and hydraulic fluid levels and lubricate all points.

- Check operator presence interlock system and brake operation. Adjust or repair any problems before using.
- Do not tamper with or defeat safety devices. Keep guards, shields and interlock safety devices in place and in proper working condition. They are for your protection.
- Keep all fasteners such as nuts, bolts and pins well secured.
- Visually inspect blades, blade bolts and the cutter assembly for wear or damage. Replace worn or damaged blades and bolts to preserve balance.
- Verify that machine and attachments, if any, are in good operating condition.
- Do not engage blades until ready to mow.

## OPERATING SAFELY

### In general

- Use extra care when loading or unloading the machine into a trailer or truck.
- Slow down and use caution when making turns and crossing roads and sidewalks. Stop blades if not mowing.
- Do not run the engine in an enclosed area where dangerous carbon monoxide fumes can collect.
- Do not place your foot on the ground while operating the machine.
- Before operating, lower the discharge chute, install the mulcher or put the entire grass catcher in place.
- Keep clear of the discharge opening at all times. Never direct the discharge toward a bystander. Stop operation if someone approaches.
- Keep washout ports and other mower housing service openings closed when mowing.
- Never leave a machine unattended. Always turn off blades, set parking brake, stop engine and remove key before dismounting.

## Starting

- Start only according to instructions in this manual or on the machine.
- Before attempting to start the engine, make sure:
  - the parking brake is on;
  - the PTO is disengaged;
  - the traction drive is in NEUTRAL.
- When starting the engine, make sure hands and feet are clear of the blades.
- Do not start the machine while standing in front of the discharge chute or with the chute directed at someone.
- Do not engage PTO at full throttle. Throttle to idle or lowest possible engine speed.
- Do not change engine governor settings or overspeed the engine. Operating the engine at excessive speed can increase the hazard of personal injury.

## MANUEVERING SAFELY

### In general

- Slow down before turning.
- Use extreme caution when reversing or pulling the mower towards you. Be sure the area behind is clear. Always look behind and down for small children and pets before and during backing.
- Be aware when approaching blind corners, shrubs, trees, tall grass or other objects that may obscure vision.
- If tires lose traction, disengage the blades. If on a slope, head downhill.
- Go slow when using a trailing seat.
- Walk, never run.

## Interrupting operation

- Before leaving the operator's position:
  - Park on level ground.
  - Disengage the PTO.
  - Set the parking brake.
  - Shut off the engine and remove the key.
- Disengage the PTO and wait until the blades quit rotating:
  - before raising cutterdeck;
  - when not mowing;
  - for transport;
  - when crossing surfaces other than grass.
- Stop the engine, disengage the PTO, set parking brake and wait until the blades quit rotating and lower cutting unit:
  - before refueling;
  - before removing grass catcher;
  - before making height adjustment unless the adjustment can be made from the operator's position.
- Stop the engine, disengage the PTO, set parking brake and disconnect the spark plug wire(s) or remove the key:
  - before clearing blockages or unclogging chute;
  - before checking, cleaning or working on the machine;
  - after striking a foreign object. Inspect the machine for damage and make repairs before restarting;
  - if the machine begins to vibrate abnormally: shut off machine immediately. Inspect and make repairs as needed before restarting;
  - except for repairs or adjustments as specifically noted, such as for carburetor adjustment, where the engine must be running. Keep hands and feet clear of moving parts in these circumstances.
- Allow the blades to come to a complete stop when stopping operation to clear blockages, unclog, inspect the machine, do maintenance or repair.
- Reduce the throttle setting during engine shut-down and, if the engine is provided with a shut-off valve, turn the fuel off at the conclusion of mowing.

## Mowing slopes



Slopes are a major factor in loss-of-control and tip over accidents that sometimes lead to severe injury or death. All slopes require extra caution.

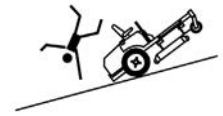

- Do not mow on slopes if uneasy or uncertain. Ultimate responsibility for safe operation on slopes rests with the operator.
- Do not mow excessively steep slopes.
- On zero turn machines, mow across slopes, not up and down.
- Avoid starting or stopping on a slope. If tires lose traction, disengage the blades and proceed slowly straight down the slope.
- With walk behind machines, mow across slopes, **not** up and down. With ride-on machines, mow up and down slopes, **not** across, except zero turn machines. Zero turn machines should mow across slopes.
- Keep all movement on the slopes slow and gradual. Do not make sudden changes in speed or direction.
- Do not turn on slopes unless necessary, and then turn slowly and downhill when possible.
- Stay away from slopes if the ground is loose or if caught in the rain during mowing.
- Use lower speeds on a slope to avoid stopping or shifting.
- Use extra care with grass catchers or other attachments. These can change the stability of the machine.
- Remove obstacles such as rocks, tree limbs etc.
- Avoid driving over obstacles such as ruts, holes, rocks and roots whenever possible. Be alert to dips and rises. Uneven terrain can overturn a mower or cause it to slide. Tall grasses can hide obstacles.
- Do not mow dropoffs, ditches or embankments. The machine could suddenly turn over if a wheel runs over the edge or an edge caves in.
- Do not mow slopes when grass is wet. Reduced traction could cause sliding.

## MAINTENANCE SAFETY

### In general

- Maintain machine according to manufacturer's schedule and instructions for maximum safety and best mowing results.
- Park machine on level ground.
- Never allow untrained personnel to service machine.
- Adjust or repair only after the engine has been stopped and the blades have quit rotating.
- Inspect grass catcher components regularly. If worn, damaged or deteriorated, they may expose moving parts or allow objects to be thrown.
- Replace parts if worn, damaged or faulty. For best results, always replace with parts recommended by the manufacturer.
- Disconnect battery or remove spark plug wire(s) before making any repairs. Disconnect the negative terminal first and the positive last. Reconnect positive first and negative last.
- Do not dismantle the machine without releasing or restraining forces which may cause parts to move suddenly.
- Provide adequate support, e.g. jackstands for lifted machine or parts if working beneath.
- Do not put hands or feet near or under rotating parts.
- Clean up spilled oil or fuel thoroughly.
- Replace faulty mufflers.
- To reduce fire hazards, keep the engine, muffler, battery compartment and fuel storage area free of grass, leaves, debris buildup or grease.
- Hydraulic fluid can penetrate skin, use paper to check for leaks. Relieve hydraulic pressure before disconnecting hoses. Make sure connections are tight and hoses are in good condition.

### Blades

- Mower blades are sharp and can cut. Use extra caution when handling. Remove obstructions with care. Wrap the blade(s) or wear gloves.
- Be aware that rotating one blade on multiblade mowers can cause other blades to rotate.
- Only replace blades. Never straighten or weld them.
- Keep other persons away from blades.



### Fuel

- Gasoline and diesel fuels are flammable; gasoline vapors are explosive. Use extra care when handling.
- Store only in containers specifically designed for fuel.
- When refueling or checking fuel level:
  - Stop the engine and allow to cool;
  - Do not smoke;
  - Refuel outdoors only;
  - Use a funnel;
  - Do not overfill;
  - If fuel is spilled, do not attempt to start the engine until the spill is cleaned up and vapors have cleared.



Sparks from static electricity can start fires or cause explosions. Flowing fuel can generate static electricity. To prevent static electricity sparks:

- Keep containers electrically grounded. Do not fill containers in a vehicle or on a truck or trailer bed with a plastic liner. Fill containers on the ground away from the vehicle.
- When practical, remove gas powered equipment from the truck or trailer and refuel it on the ground. If equipment must be refueled on the truck or trailer, refuel from a portable container rather than a dispenser nozzle.
- Keep the dispenser nozzle in contact with the rim of the fuel tank or container opening until fueling is complete. Do not use a nozzle lock-open device.
- Replace caps on fuel cans and tanks securely.



## BATTERY

Battery acid is caustic and fumes are explosive and can cause serious injury or death.

To reduce the risk of personal injury when working near a battery:

- When working with battery acid, use protective equipment such as, but not limited to, goggles, face shield, rubber gloves and apron.
- Avoid leaning over a battery.
- Do not expose a battery to open flames or sparks.
- Be sure batteries with filler caps are properly filled with fluid.
- Do not allow battery acid to contact eyes or skin. Flush any contacted area with water immediately and get medical help.
- Use AGM charger. Charge batteries in an open, well ventilated area, away from sparks and flames. Unplug charger before connecting or disconnecting from battery.

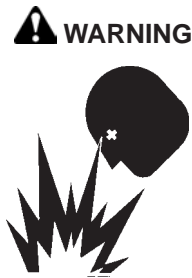

## STORAGE SAFETY

- Stop the engine and allow to cool before storing.
- Drain the fuel tank outdoors only.
- Store fuel in an approved container in a cool, dry place.
- Keep the machine and fuel containers in a locked storage place to prevent tampering and to keep children from playing with them.
- Do not store the machine or fuel container near heating appliances with an open flame such as a water heater or an appliance with a pilot light.
- Keep gasoline storage area free of grass, leaves and excessive grease to reduce fire hazard.
- Clean grass and debris from cutting units, drives, mufflers and engine to help prevent fires.

## JUMP STARTING

1. Be sure the jumper cables are in good condition. Turn off the ignition and all electrical accessories on both machines.
2. Position the machine with a good (charged) battery next to but not touching the machine with the dead battery so jumper cables will reach.
3. When making cable connections:
  - make sure the clamps do not touch anywhere except to intended metal parts,
  - Never connect a positive ("+" or red) terminal to a negative ("- " or black) terminal.
  - Make sure the cables won't get caught in any parts after the engines are started.
4. Connect one end of the first jumper cable to the **positive** terminal on one battery. Connect the other end to the **positive** terminal on the other battery.
5. Connect one end of the other cable to the **negative** terminal of the machine with a good (charged) battery. Make the final connection on the engine of the machine to be started, away from the battery.
6. Start the vehicle with the good battery, then the machine with the discharged battery.
7. Remove the cables in the exact reverse order of installation. When removing each clamp, take care it does not touch any other metal parts while the other end remains attached.

## HYDRAULIC SYSTEM

The machine's hydraulic system operates under high pressure.

- When checking for leaks, do not use your hands to attempt to find a leak. Instead, use cardboard or paper.
- Escaping hydraulic fluid can be under sufficient pressure to penetrate skin and cause serious injury.
- If hydraulic fluid is injected into the skin, it must be promptly removed by a doctor familiar with this form of injury or gangrene may result.
- Check that all hydraulic fluid connections are tight and all hydraulic hoses and lines are in good condition before applying pressure to the system.





**WARNING**

**-DO NOT OPERATE WHERE FLYING DEBRIS MAY INJURE PEOPLE OR DAMAGE PROPERTY. KEEP PEOPLE AND PETS AT A SAFE DISTANCE.**

**-DO NOT USE IF THERE ARE ANY DOUBTS ABOUT SAFETY.**

**-KEEP LABELS, GUARDS AND SHIELDS IN PLACE. REPLACE IF LOST OR DAMAGED. REPLACE OPERATORS MANUAL IF LOST OR DAMAGED.**

**-OBEY SAFETY INSTRUCTIONS. FAILURE TO DO SO MAY CAUSE INJURY TO YOURSELF OR OTHERS.**

**-DO NOT DEFEAT INTERLOCKS. CHECK OPERATION DAILY.**

**-DO NOT ALLOW CHILDREN, UNSKILLED OR UNTRAINED PERSONS TO OPERATE MACHINE.**

**-DISCONNECT SPARK PLUG WIRE(S) BEFORE DOING ANY MAINTENANCE.**

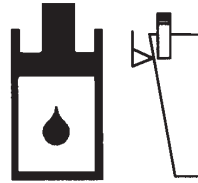

**HYDRAULIC OIL  
FILL TO LEVEL  
INDICATED WITH  
10W30 OIL.**



**WARNING**



**HIGH PRESSURE FLUID:  
-LEAKS CAN PENETRATE SKIN.**

**-SEEK IMMEDIATE MEDICAL ATTENTION FOR OIL PENETRATION INJURY.**

**-SEE OPERATORS MANUAL FOR PROPER METHOD OF LOCATING LEAKS, OR SERVICING HYDRAULIC SYSTEM.**

2000661



**ADVERTENCIA**

1. Leer el manual del operador. No permitir que personas no capacitadas para ello usen la máquina.
2. Mantener los protectores en su lugar y sus tornillos debidamente fijados.
3. Antes de limpiar, ajustar o reparar este equipo, apagar todos los mandos, aplicar el freno de estacionamiento y apagar el motor.
4. Mantener las manos, los pies y la ropa alejados de las piezas en movimiento.
5. No conducir como pasajero ni llavar pasajeros en máquinas sin asiento para ello.
6. Mantener a las demás personas alejadas durante el funcionamiento de la máquina.
7. Si no sabe leer inglés, solicitarle a otra persona que le lea y explique el contenido de las etiquetas y del manual de la máquina.

340830

**IMPORTANT**

- Close fuel valve before transporting.**
- Flooding can cause hard starting and engine damage.**
- See Operators Manual.**

2000571





**Operator's  
Manual**



**Inflate tires  
to 14 psi  
(1.0 kg/cm²)**

2000673

	<p><b>⚠ DANGER</b></p> <p><b>ROTATING BLADES</b></p> <p>KEEP HANDS AND FEET AWAY</p> <p>STOP ENGINE AND LET BLADES STOP BEFORE REMOVING GRASS COLLECTOR OR UNCLOGGING.</p>		<p><b>⚠ WARNING</b></p> <p><b>THROWN OBJECTS</b></p> <ul style="list-style-type: none"> <li>- KEEP AREA CLEAR OF PEOPLE AND PETS.</li> <li>- REMOVE OBJECTS BLADE MAY STRIKE AND THROW.</li> <li>- STOP BLADES TO CROSS GRAVEL AREAS.</li> <li>- DO NOT OPERATE WITHOUT CHUTE, MULCHER OR ENTIRE GRASS COLLECTOR IN PLACE.</li> </ul> <p>4164269</p>
---	--	---	--

**⚠ WARNING**



- ROTATING PARTS.  
- DO NOT OPERATE WITH COVER REMOVED

2000577

**⚠ WARNING**



**TO CHECK OR ADD FUEL:**

- Do it outdoors.
- Stop engine. Allow to cool.
- Do not smoke.
- Clean up spilled fuel.
- Do not overfill.
- Fill to one inch below bottom of filler neck.

2000570

**THIS PRODUCT IS MANUFACTURED UNDER ONE OR MORE U.S. PATENTS. FIND PATENTS BY MODEL NUMBER AT [WWW.SGCPATENTS.SCHILLERGC.COM](http://WWW.SGCPATENTS.SCHILLERGC.COM)**

4169490

**⚠ WARNING**



**SPARKS OR FLAME CAN START EXPLOSION. DISCONNECT (-)NEGATIVE TERMINAL FIRST. RECONNECT (-)NEGATIVE TERMINAL LAST.**

2000590

**⚠ WARNING ⚠**

- REMOVE DEBRIS BUILDUP. DEBRIS UNDER BELT COVER OR NEAR MUFFLER CAN CAUSE FIRES.
- BLADES CONTINUE TO ROTATE FOR A FEW SECONDS AFTER BLADES ARE TURNED OFF.
- BLADES MUST BE AT LEAST 1/8" ABOVE BOTTOM OF HOUSING.
- ALL BLADES MUST BE IDENTICAL. CHECK BLADE BOLTS DAILY FOR TIGHTNESS.
- INSPECT FOR DAMAGE AFTER STRIKING A FOREIGN OBJECT. MAKE REPAIRS BEFORE RESTARTING OPERATION.
- FIND AND REPAIR CAUSE OF ANY ABNORMAL VIBRATION.

2000572

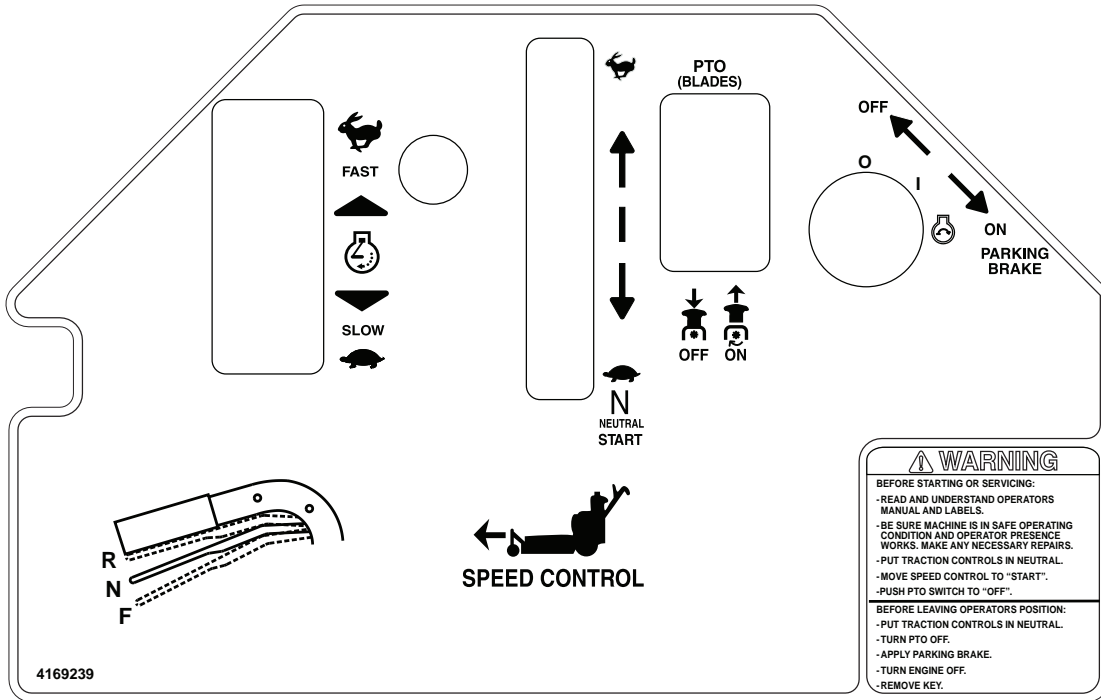

**WARNING**

BEFORE STARTING OR SERVICING:  
 - READ AND UNDERSTAND OPERATORS MANUAL AND LABELS.  
 - BE SURE MACHINE IS IN SAFE OPERATING CONDITION AND OPERATOR PRESENCE WORKS. MAKE ANY NECESSARY REPAIRS.  
 - PUT TRACTION CONTROLS IN NEUTRAL.  
 - MOVE SPEED CONTROL TO "START".  
 - PUSH PTO SWITCH TO "OFF".

BEFORE LEAVING OPERATORS POSITION:  
 - PUT TRACTION CONTROLS IN NEUTRAL.  
 - TURN PTO OFF.  
 - APPLY PARKING BRAKE.  
 - TURN ENGINE OFF.  
 - REMOVE KEY.

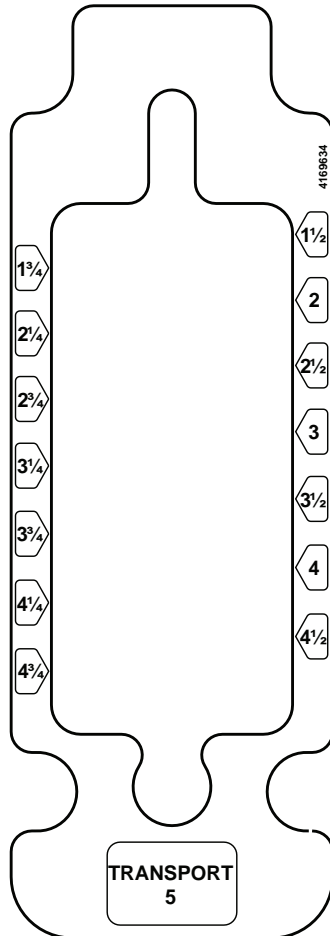

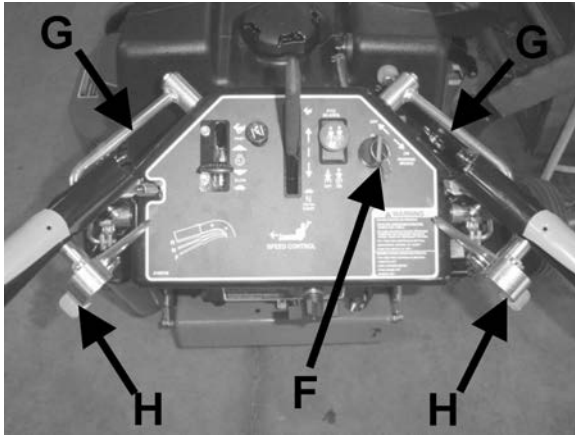

## KEYSWITCH (F)

Electric start models: Turn key to right and hold until machine starts. When machine starts, let go of key and it will return to run position. Turn key to left to stop engine.

**HOUR METER (M)** - Records accumulated time the machine is in operation and provides service alerts. Push and release MODE button to toggle between functions. Provided service alerts include change engine oil and filter, change hydraulic oil, and service air filter. When the service time is approaching, an alert message will flash temporarily, interrupting whatever mode the meter is in. This will continue until the alert is reset. When the service interval reaches "0" hours, the word "NOW" replaces the hours remaining. To reset the service alert, depress and hold down the mode button for 6 seconds while in the alert to be cleared.

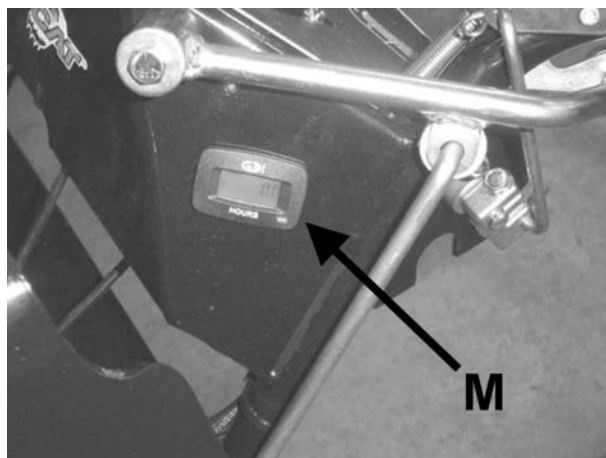

## TRACTION CONTROL LEVERS (G)

### TRACTION LOCKS (H)

The traction locks provide a neutral position when pulled back and locked with traction control levers.

**To release:** pull the traction control levers up enough to push forward on the locks.

### NOTE:

- Squeezing the traction levers past the neutral position will cause the machine to back up)
- Both traction control levers must be released at the same time in order to go straight ahead. Using one traction control lever will cause the machine to turn to one side.
- When using the locks to provide a neutral position be sure the traction control rods are fully seated in the rear notch of the traction locks. Failure to do this may result in serious injury.

The traction control levers have **five** functions:

1. To provide a neutral position to stop the machine or to start the engine. Squeeze the levers enough to engage the traction lever locks by moving the tops of the locks towards the handgrip, then release the levers.
2. To engage the drive to wheels: gradually release the traction control levers to the speed set by the speed control and throttle.
3. To stop: pull the levers up to neutral.
4. To steer the unit: pulling up on the R.H. lever will initiate a R.H. turn and pulling up on the L.H. lever will initiate a L.H. turn.
5. To back up: squeeze the levers equally past neutral. This may be done any time the engine is running and the speed selector is not set in neutral, allowing instant forward/reverse operation and zero turning with one wheel driving forward and one wheel driving backward. Releasing the traction lever from reverse automatically returns the machine to neutral or the preset forward speed, depending on where the traction locks are set.

**NOTE:** There is a noticeable difference in the force required at the traction levers in the transition from neutral to reverse.

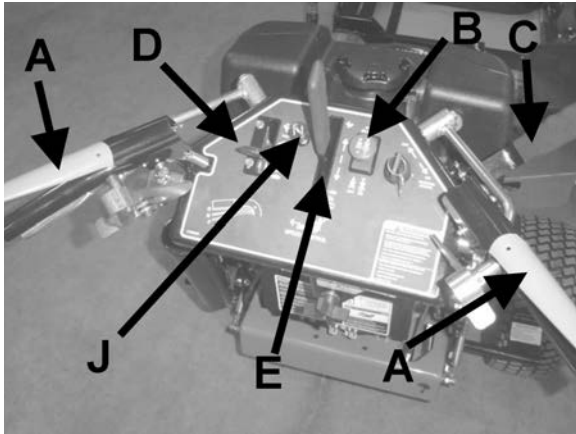

### OPERATOR PRESENT CONTROLS (A)

The control levers must be held down for PTO operation and to shift the speed control out of neutral. If the PTO switch is on or speed control is shifted from neutral and the control levers are released, the engine will kill. On electric start models the control levers must be released, the blades must be off and the speed control must be in neutral for the engine to start.

### PTO SWITCH (B)

- DO NOT START CUTTING BLADES UNTIL READY TO START MOWING.
- DO NOT ENGAGE PTO AT FULL THROTTLE. SET ENGINE SPEED MIDWAY BETWEEN HIGH IDLE AND LOW IDLE FOR ENGAGEMENT.
- Disengage drive to cutting blades whenever you stop or leave the operators position.
- Shut off engine and remove spark plug wire before making adjustments or unplugging mower.
- The drive to the cutters is engaged when the PTO switch is pulled up toward the operator (**ON**) and disengaged by pushing the PTO switch back down (**OFF**).

### PARKING BRAKE (C)

Pull lever back to engage parking brake. Push lever forward to disengage parking brake.

### THROTTLE CONTROL (D)

By moving the throttle lever forward towards the engine, the engine speed is increased until the maximum governed rpm is obtained. By moving the throttle lever fully back, the engine will idle down. On engines with an integrated choke, Moving the throttle lever forward to the detent gives maximum governed rpm. Moving it past the detent, chokes the engine.

### SPEED SELECTOR (E)

The speed selector levers in the center of the control panel set the maximum forward and reverse speeds. The further the levers are moved forward, the faster the maximum preset speed. The levers must be moved forward for both forward and reverse speeds. Speed changes can be done on the go. The operator present levers must be held down or the engine will kill when the speed control levers are moved out of the neutral position.

### TRACKING ADJUSTMENT KNOB (I)

The tracking adjustment knob provides on-the-go tracking control to correct for any hydraulic circuit or linkage differences from one side to the other.

To correct tracking:

1. Rotate the tracking adjustment knob to the right to make the machine track to the right.
2. Rotate the tracking adjustment knob to the left to make the machine track to the left.

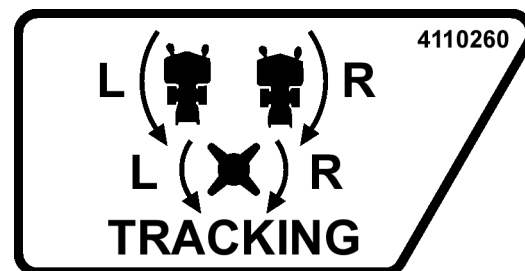

### CHOKE (J)

Provided with engines that do not have the integrated choke/throttle D. Pull up on choke control to engage choke when starting the engine. Push down on choke control to open choke after engine starts.

## PRE-OPERATION CHECK LIST (OWNER'S RESPONSIBILITY)

- \_\_\_ Review and follow all safety rules and safety decal instructions.
- \_\_\_ Check that all safety decals are installed and in good condition. Replace if damaged.
- \_\_\_ Check to make sure all shields and guards are properly installed and in good condition. Be sure that either the discharge shield or complete vacuum attachment is installed.
- \_\_\_ Check that all hardware is properly installed and secured.
- \_\_\_ Check that equipment is properly and securely attached to power unit.
- \_\_\_ Check to be sure engine is free of dirt and debris. Pay particular attention to the cooling fins, governor parts and muffler. Clean air intake screen. Check air cleaner; service if necessary.
- \_\_\_ Never allow riders.
- \_\_\_ Inspect area and remove stones, branches or other hard objects that might be thrown, causing injury or damage.
- \_\_\_ Clean area around oil fill dipstick. Remove dipstick and check to be sure oil is in operating range (between marks on dipstick). Add oil if necessary but **Do Not Overfill**. Install dipstick assembly firmly until cap bottoms out on tube. Dipstick assembly must always be secured into fill tube when engine is running.
- \_\_\_ Check all lubrication points and grease as instructed in manual.
- \_\_\_ Check hydrostatic fluid level. Check to be sure cooling fins on hydrostat are clean.
- \_\_\_ Perform a functional check of the safety interlock system each time you operate the unit.

## FUELING

- Fill fuel tanks with good quality, clean, unleaded gasoline. Do not use hi-test fuel.
- Use a funnel to avoid spillage.

### WARNING



 **WARNING**

---



**TO CHECK OR ADD FUEL:**

- Do it outdoors
- Do not smoke
- Stop engine; allow to cool
- Fill to one inch below bottom of filler neck
- Do not overfill
- Clean up spilled fuel

## BEFORE STARTING THE ENGINE

- Be familiar with all controls, how each functions and what each operates.
- Check the engine oil level and add if necessary. Open the fuel valves under each fuel tank. Select which tank to draw fuel from with the fuel selector valve.
- **Choke:** For cold starts, set the throttle lever to the half-open position and pull the choke out to the ON position. For warm starts set the throttle to the half-open position and the choke to the OFF position.

## OPERATOR PRESENCE INTERLOCK SYSTEM

To start the engine:

- The PTO switch must be **OFF**.
- Both traction levers must be in the neutral lock position.
- The parking brake must be **ON**.

To operate the machine:

1. The operator must be in the seat or engaging the PTO will kill the engine.
2. The parking brake must be **OFF** and the operator must be in the seat, or moving a traction lever from the neutral lock position will kill the engine.

## STARTING THE ENGINE

1. For Recoil Starter: Pull the rope operated recoil starter firmly. Allow the rope to recoil slowly before releasing the handle. For Electric start, turn the key to operate electric starter to start the engine. Release the key when the engine starts.
2. If the engine does not start immediately, do not crank for more than 10 seconds at a time. Allow 60 seconds for the starter motor to cool down between starting attempts to prevent the starter motor from burning out.
3. If the choke is ON when the engine starts, gradually back it off until the engine runs with no choke at all.

## OPERATING THE MACHINE

- Practice at slow engine and travel speeds with the PTO off until fully familiar with the controls.
- For normal cutting the throttle should be set at the full open position. By using the traction levers to speed up or slow down the machine during use, maximum control and cutting efficiency can be maintained.
- Using the machine at less than full throttle in heavy conditions will cause the engine to labor and result in excessive wear to the engine and hydraulic system. that wheel to back up.
- To change speeds, depress the operator present controls then move speed control levers to desired speed.

## DRIVING

1. With the PTO disengaged, move the parking brake to OFF.
2. Move both traction levers out of neutral lock.
3. Push both traction levers forward evenly to drive forward in a straight line. Pull both traction levers back evenly to drive backward in a straight line.
4. **Steering** - Move one lever forward and one back.

### Turns during forward movement:

- **Right turn** - move the right traction lever back toward neutral to slow the right drive wheel.
- **Left turn** - move the left traction lever back toward neutral to slow the left drive wheel.

### Turns during reverse movement:

- **Reverse right turn** - move the right traction lever forward toward neutral to slow the right drive wheel.
- **Reverse left turn** - move the left traction lever forward toward neutral to slow the left drive wheel.

### CAUTION

Use caution when making turns. Slow down before making sharp turns to help maintain control and to prevent torn turf from skidding or spinning tires. To help prevent turf damage, keep both drive tires moving whenever a turn is made.

**TIP:** The best way to make a sharp "zero" turn is to come to a stop, get the machine moving in reverse with both drive wheels and then powering the machine around with the outside wheel. This technique keeps the drive tires turning and results in less turf damage.

## DRIVING THE MACHINE IN TRANSPORT

1. With the PTO switch disengaged, and the operator present controls depressed, move the speed selector lever to give the required forward speed.
2. Release the traction lever locks and gradually engage both traction control levers together.

**NOTE:** Engaging only one traction lever will cause the machine to turn to one side. Squeezing one traction lever past neutral will cause the machine to back up to one side.



## CUTTING

1. Place the discharge chute in the down position or correctly fit a grass collector or mulcher plate.
2. Sit in the seat.
3. Start the engine.
4. Turn the blades on by pulling up on the PTO switch. Do not start the blades at full throttle. Instead, use the slowest throttle setting that will allow the engine to pick up the blade load to reduce the wear on the belts and electric clutch.
5. After the blades are rotating, set the throttle to maximum. Use the traction levers to obtain the required cutting speed, to steer around obstacles and to turn at the end of a cut.

## CUTTING TIPS

- When mowing large areas, start by turning to the right so that clippings will be discharged away from shrubs, fences, driveways, etc. After two or three rounds, mow in the opposite direction, left hand turns, until finished.
- If grass is extremely tall, it should be mowed twice, the first cut relatively high, the second cut to the desired height.
- Use the left side of the mower for trimming.
- Choose cutting directions so that clippings are thrown onto areas that already have been cut. This method results in the most even distribution of clippings and more uniform, better appearing cuts.
- Use a different mowing pattern each time a property is cut where possible. This helps prevent rutting and leads to a more uniform cut by keeping the grass from always laying the same way.

## TO STOP THE MACHINE

1. Pull traction levers up to neutral.
2. Engage the traction lever locks in neutral position.
3. Disengage the cutterdeck with PTO switch.
4. Move speed control to neutral.
5. Close the throttle to slow the engine, turn engine off with the keyswitch.

NOTE: When the machine is transported by truck or trailer or left to stand unused, the fuel valve (under the fuel tank) should be turned off. This avoids the possibility of flooding should any dirt get under the carburetor float needle. Leaving the fuel valve open can allow severe flooding which may ruin the engine by diluting the oil.

## PUSHING THE MACHINE WITH THE ENGINE STOPPED:

Open dump valve **V** on each pump by turning counter clockwise two revolutions. Move the machine and close dump valve **V** by turning clockwise until valve is firmly seated.

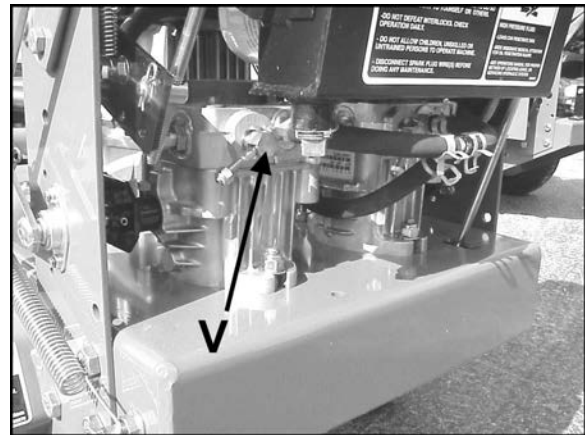

	<h3>WARNING</h3>
	<p><b>THROWN OBJECTS</b></p> <ul style="list-style-type: none"> <li>- KEEP AREA CLEAR OF PEOPLE AND PETS.</li> <li>- REMOVE OBJECTS BLADE MAY STRIKE AND THROW.</li> <li>- STOP BLADES TO CROSS GRAVEL AREAS</li> <li>- DO NOT OPERATE WITHOUT CHUTE, MULCHER OR ENTIRE GRASS CATCHER IN PLACE.</li> </ul>

	<h3>DANGER</h3>
	<p><b>ROTATING BLADES</b></p> <ul style="list-style-type: none"> <li>- KEEP HANDS AND FEET AWAY.</li> <li>- STOP ENGINE AND LET BLADES STOP BEFORE REMOVING GRASS COLLECTOR OR UNCLOGGING.</li> </ul>

## MACHINE LUBRICATION

Every 50 Working Hours - Lubricate the following points with grease:

- 1) Caster wheel pivots (2 points)
- 2) Neutral eccentric pin (2 points)
- 3) Idler pivot bearings:
  - a) Engine to cutterdeck belt tensioner
  - b) Cutterdeck belt tensioner
  - c) Hydro drive belt tensioner
- 4) Pull arms (4 points)
- 5) Deck lift pivots (4 points)
- 6) HOC handle pivot (1 point)

**NOTE:** The spindles used on these machines use a superior sealed bearing which does not require relubrication.

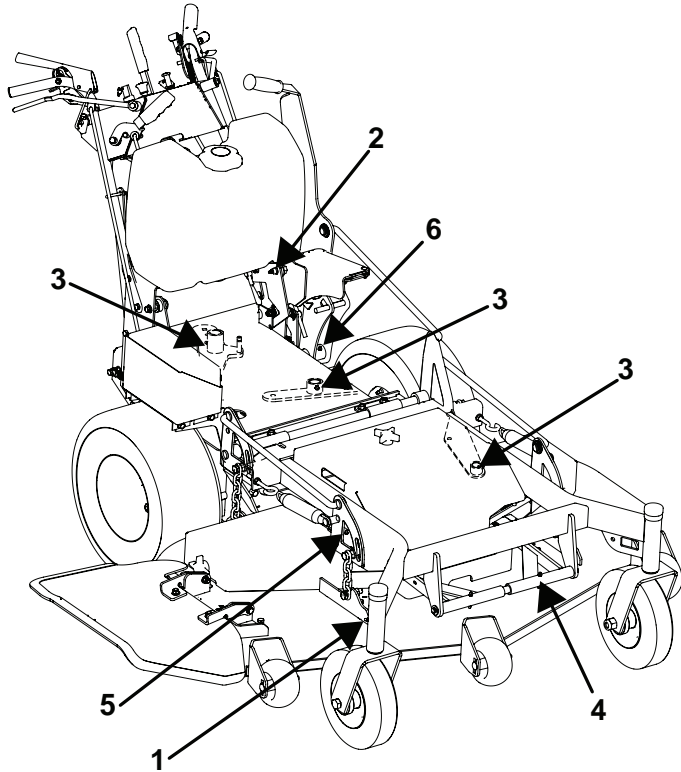

## ENGINE - KAWASAKI

The maintenance schedule detailed is for average operating conditions. Under extreme conditions (dusty, dirty or more than 8 hrs continuous use) maintain more frequently.

### Cooling Fins and Air Intake screen (daily)

Ensure that the cooling fins and air intake screen **W** are cleaned daily. Continued operation with a clogged cooling system will cause severe overheating and result in engine damage. You can use compressed air to clean.

### AIR CLEANER

Clean and replace the air cleaner element as specified in the service chart. Uneven running, lack of power or black exhaust may indicate a dirty air cleaner.

1. Unclamp end cover **C** and remove existing cleaner element **A**.
2. Insert new element **A** and replace cover **C**. Ensure breathing port **B** is pointing down and away from the muffler.

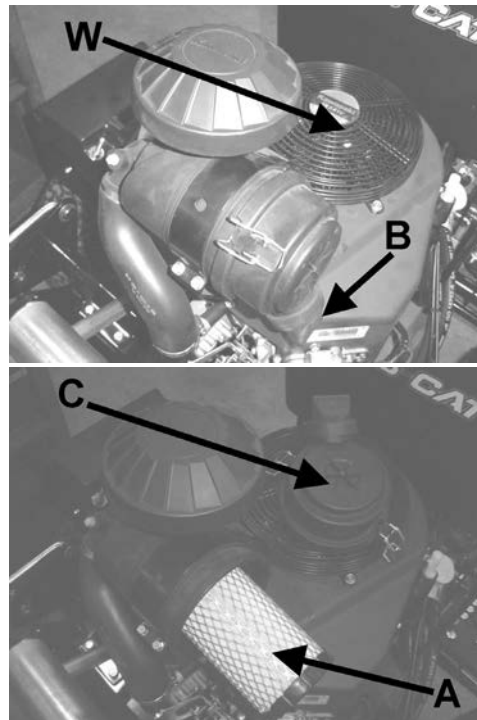

## ENGINE OIL

Do not perform engine maintenance without the engine off, spark plug wires disconnected and PTO disengaged.

### AFTER FIRST FIVE (5) HOURS

While the engine is warm:

1. Release the oil drain hose assembly from the engine clip **J**. Lay hose assembly over the frame edge or through the frame cutout, which ever is most convenient.
2. Remove the rubber cap **D** from the tip of the hose assembly and turn the drain valve to allow oil to drain from the engine. Dispose of used oil in accordance with local requirements.
3. Clean drain valve and tighten the plastic portion of the drain valve back into the metal portion of the valve. Replace rubber cap over the tip of the valve. Replace hose assembly back into engine clip.
4. Change oil filter.
5. Fill the crankcase with fresh oil to the full mark. Do not overfill. See engine manual for oil specifications.

### DAILY

1. Check oil level with the dipstick.
2. If oil is needed, add fresh oil of proper viscosity and grade. See engine manual for oil specifications. Do not overfill.
3. Replace dipstick before starting engine.

### PERIODIC OIL CHANGES

1. See engine manual for oil and filter change intervals after the break-in period.
2. Follow instructions for first oil change, above.

## FUEL SHUT-OFF VALVE

Your unit comes equipped w. a fuel shut-off valve **S**. Turn the valve lever 90° to shut the fuel off from the tank.

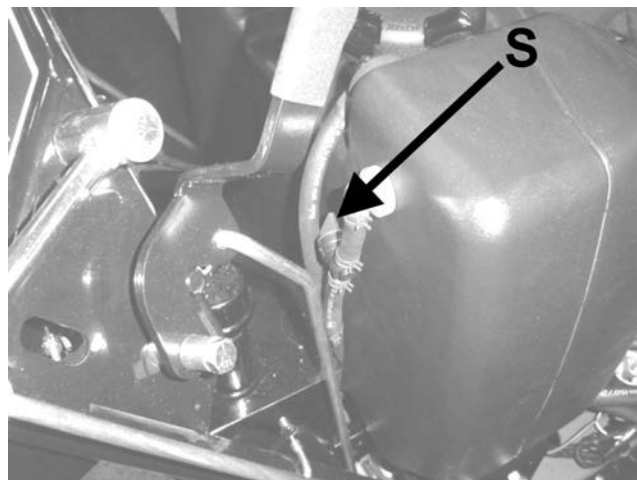
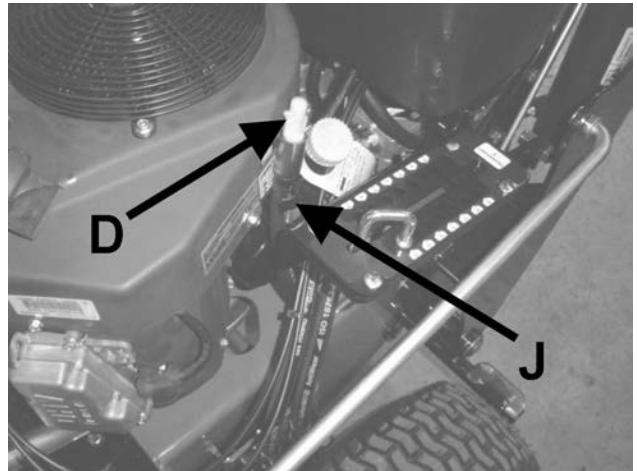

## Blade Sharpening

Blades may be sharpened by filing or grinding, but with either method the balance of the blades must be maintained at 5/8 oz/in or less. Failure to maintain balance causes excess vibration, wear and shortened life of not only the blades, but most all components of the machine. To balance a blade after sharpening: attach 1/8 oz of weight 5" from center on the light end. This should make the light end the heavy end. If it does not: File or grind the heavy end until the addition of weight makes the light end the heavy end.

### NOTE:

- Do not overheat or weaken the blades.
- Do not straighten bent blades. Replace with new BOB-CAT blades.  
If lift portion of blade is worn thin replace with a new BOB-CAT blade.
- ALWAYS replace with BOB-CAT blades—do not use another manufacturer's blades as this could be dangerous.
- Replace cracked or bent blades.

## BLADE REMOVAL

1. Use a box wrench or socket with a long breaker bar to remove spindle bolt under cutterdeck.
2. Slip tube over breaker bar or wrench if necessary to gain leverage.
3. Keep hands clear as blades may rotate when bolt releases.
4. When changing blades, wear thickly padded gloves.
5. Block blades from turning by using a piece of wood.
6. Follow these instructions to prevent injury when bolt releases.

**NOTE:** To prevent blade from turning, place block of wood at **A**, with grain perpendicular to blade.

## BLADE RE-INSTALLATION

1. Place the desired number of spacers (no more than 2) on the spindle bolt below the cutterdeck between the blade and spindle shaft.
2. Insert the cutter spindle bolt (from bottom) complete with washer, blade and spacers.
3. Place remaining spacer(s) on the spindle bolt above the cutterdeck between the conical washer and nut (as shown). Replace nut and tighten to 70 ft-lbs.

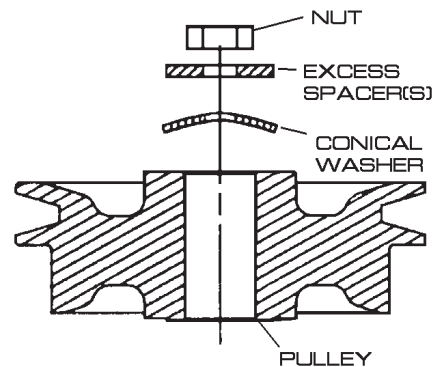
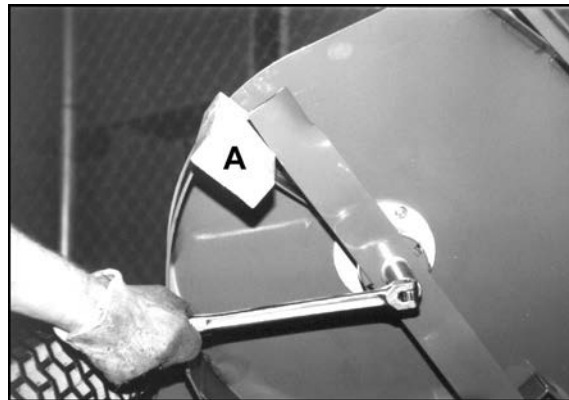

**Cutterdeck Pulley Assembly**

## SPARK PLUG

- Remove plug and check condition.
- Good operating conditions are indicated if the plug has a light grey or tan deposit. A white blistered coating may indicate overheating. A black coating usually means an “over rich” fuel mixture caused by a clogged air cleaner or improper carburetor adjustment. Do not sandblast, wire brush or otherwise try to clean a dirty plug. Best results are obtained with a new plug.
- See engine manufacturers manual for proper spark plug gap.

## HYDRAULIC RESERVOIR CHECK, DRAIN AND FILL

Check level every 100 hours or when a leak has occurred. To check level: Remove reservoir cap. Add 10W30 oil until the oil level reaches the bottom of the filler tube. Do not overfill.

### EVERY 500 HOURS:

Change hydraulic oil and filter. Remove plug **D** to drain reservoir. Remove and replace filter. Filter is located on front of tank at **G**. Reinstall plug and fill with 10W30 oil to the bottom of the filler tube **F**.

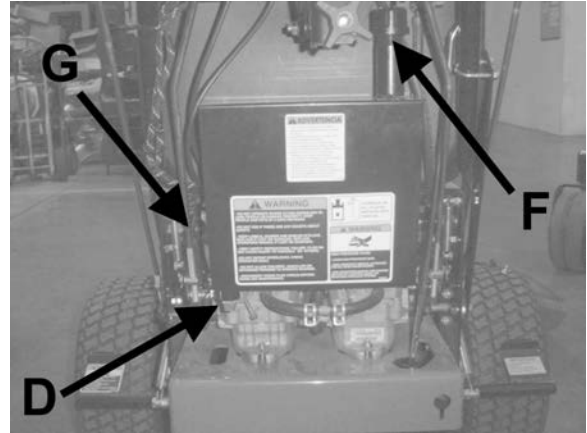

## In-Line Fuel Filter

When required, the fuel filter **X** may be replaced. See the Setup, Parts & Maintenance manual for service part numbers.

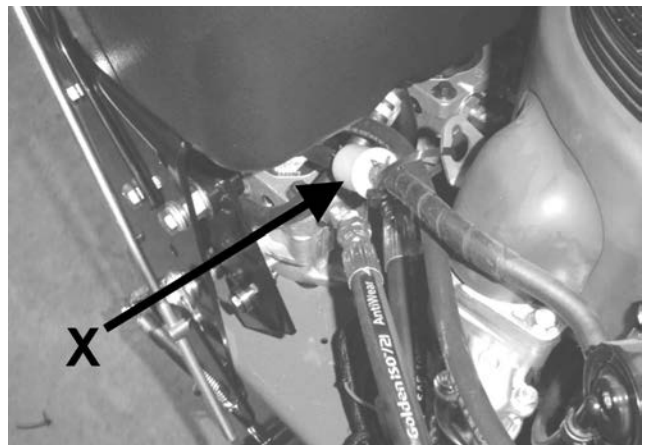

# MAINTENANCE CHART

# Hydro Midsize

**NOTE: CHANGE ENGINE OIL AND FILTER AFTER FIRST 5 HOURS OF OPERATION.**

<b>SERVICE OPERATION</b>	<b>FIRST 5 HOURS</b>	<b>DAILY</b>	<b>EVERY 25 HOURS</b>	<b>EVERY 50 HOURS</b>	<b>EVERY 100 HOURS</b>	<b>EVERY 500 HOURS</b>
<b>ENGINE</b>						
Check Oil Level		X				
Check for Oil & Air Leaks		X				
Clean Air Intake		X				
Clean Air Cleaner		X				
Change Oil & Filter*	X	<b>SEE ENGINE MANUFACTURER'S MANUAL*</b>				
Clean Fuel Sediment Bowl				X		
Replace/Adjust Spark Plug	<b>SEE ENGINE MANUFACTURER'S MANUAL</b>					
<b>HYDRAULIC OIL RESERVOIR</b>						
Check Oil Level		X				
Change Hydraulic Oil						X
<b>MACHINE</b>						
Check Tire Pressures		X				
Lubricate All Points				X		

**Consult the manufacturer's manual for your engine for further information and instructions.**

## NOTES

---



---



---



---



---



---



---



---



---



---



---



---



---



---



---



---

<b>GENERAL</b>	DATE	HRS	DATE	HRS	DATE	HRS	DATE	HRS	DATE	HRS	DATE	HRS
Check Tire Pressures												
Lubricate All Points												
Check Nuts & Bolts												
<b>ENGINE</b>												
Check Oil Level												
Change Oil												
Clean Air Cleaner Element												
Clean Cooling Fins												
Replace Air Cleaner Element												
Clean & Gap Spark Plugs												
NOTE: After first 5 hours of operation replace engine oil and filters.												

## HEIGHT OF CUT

The height of cut is set by moving height of cut pin **A** to the hole designated for the height of cut desired.

To change the height of cut:

1. Lift the deck by pulling back on handle **X** until the lift lever **L** latches the handle **X** in transport position.
2. Move pin **A** to the selected hole.
3. Lower the deck by pulling handle **X** toward you until it stops and then letting the handle **X** rotate away from you until the latch lever **E** is stopped by the pin **A**.

### NOTES:

- Height of cut may vary due to the amount of tread on the tires, tire diameter or inflation pressure.
- For best results, adjust the rear deck rollers, if equipped with them, for the height of cut to be used. See page 23.

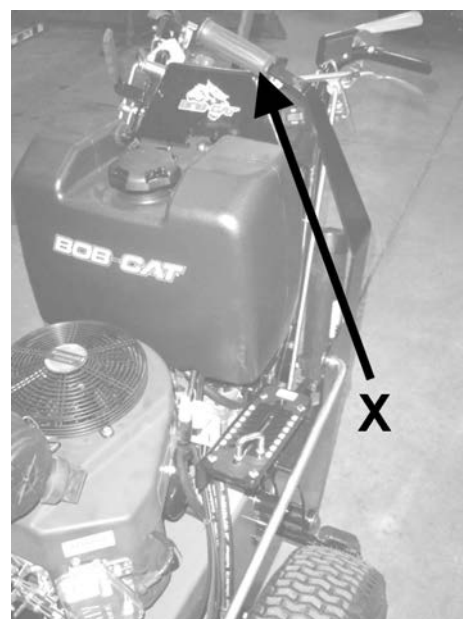
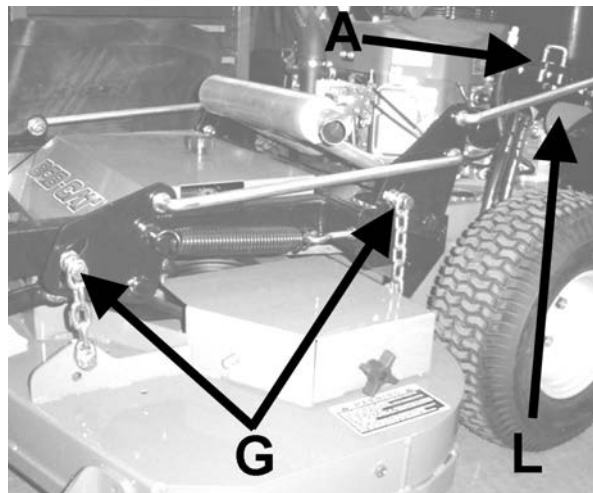
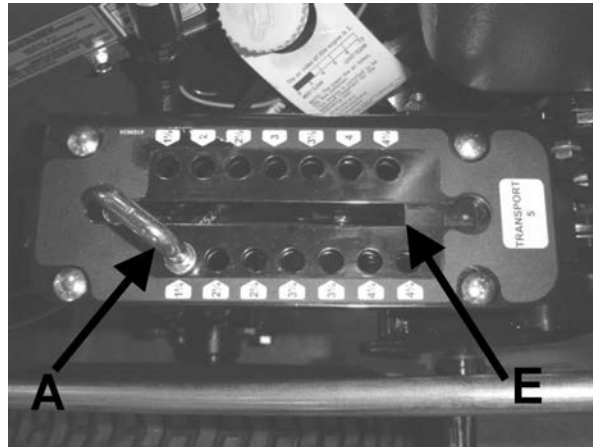



### DECK ROLLERS

The deck rollers are adjustable up and down to provide improved deck flotation and scalping protection at various heights of cut. They are not intended to ride continuously on the ground. Adjust no closer than 3/8" (10mm) to the ground.

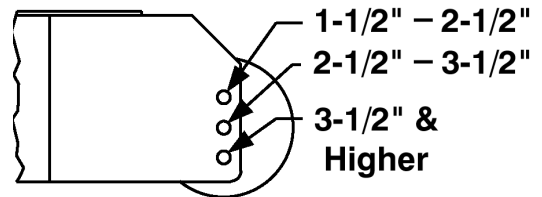

Height of cut ranges for roller adjustment

### DECK LEVELING

1. Park the machine on a smooth, level surface. Raise the deck to the transport position.
2. Lower the deck onto a set of equal height blocks under the rear corners of the deck. Place another set of blocks under the front of the deck so that the deck top is pitched forward 1/8".
3. Measure the height of the blade cutting edge above the ground. Remove pin **A** and set the pin in the corresponding position to that height.
4. Loosen nuts on bolts **G**. Move bolts in slot to help position deck. Tighten nuts on bolts **G**.

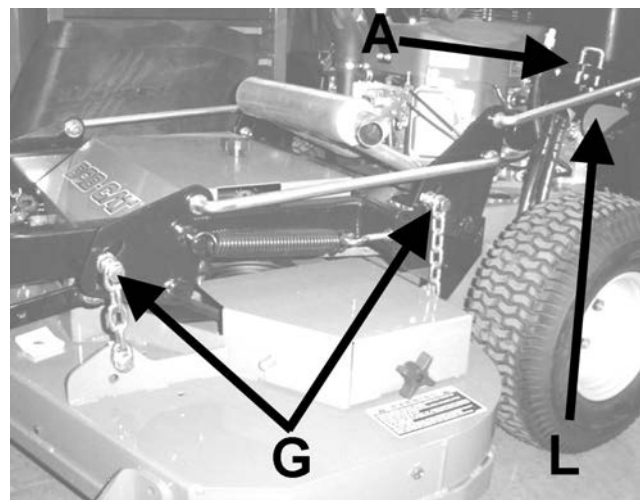

A 1/8" forward pitched deck provides the best horsepower.  
A level deck provides the best quality of cut.  
A 1/8" rearward pitched deck provides the best striping.  
Certain grass types and conditions may vary.

## PTO BELT

1. Rotate idler arm using a 3/8" ratchet or breaker bar and remove belt.



## CUTTERDECK BELT

1. Remove PTO belt.
2. Rotate idler arm using a 3/8" ratchet or breaker bar and remove belt.
3. Replace in the reverse order.



## PUMP-DRIVE BELT

1. Remove PTO belt from the engine clutch.
2. Disconnect the clutch wire harness.
3. Unbolt clutch bracket from clutch and rotate the clutch to allow enough clearance to remove the clutch bracket.
4. Rotate idler arm using a 3/8" ratchet or breaker bar inserted into the square hole in the idler arm.
5. Remove pump drive belt.
6. Replace by following steps in reverse order.

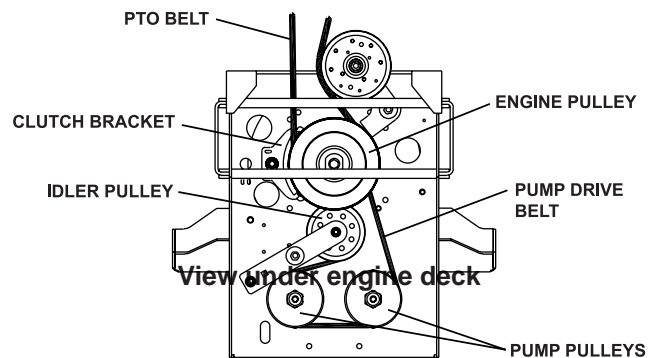

# Hydro Midsize



Make all adjustments with the engine shut off, spark plug wire disconnected and mower drive disengaged.

## NEUTRAL SWITCH ADJUSTMENT

The neutral switch **N** should be adjusted so that it is engaged by the speed control lever **C** when in the neutral position, and disengaged just before the wheels being to move by adjusting the speed control lever **C** from the neutral position to the forward position.

### TO ADJUST:

1. Complete the traction drive adjustments.
2. Place the machine on jack stands or blocks such that the drive wheels are off the ground and the machine is stable.
3. Adjust the speed control lever **C** to the neutral position.
4. Adjust the neutral switch **N** to a position where it will disengage just before the wheels move by adjusting the speed control lever **C** from the neutral position to the forward position.

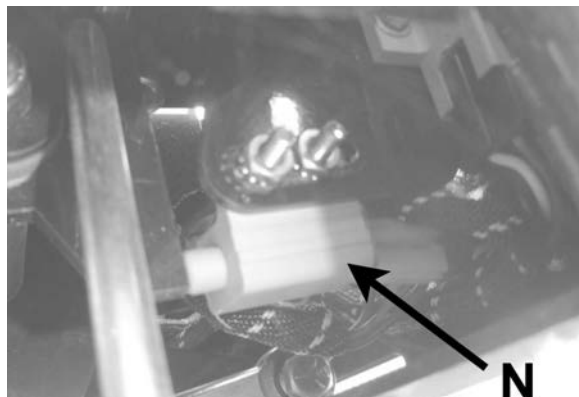
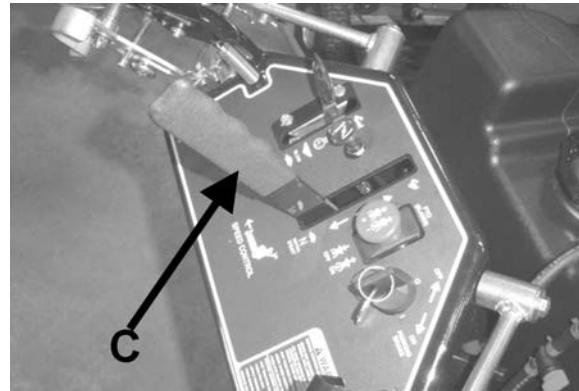

## TIRE PRESSURE ADJUSTMENT

Tire pressures should be maintained at 14 psi (1.0 kg/cm<sup>2</sup>).



### PARKING BRAKE

Apply parking brakes and open the bypass valves on the hydraulic pumps. Try to push the machine forward. If wheels rotate, adjust brakes as follows.

#### TO ADJUST:

1. Remove the hairpin cotter **A** from the brake rod at the brake lever as shown.
2. Slide the brake rod out of the brake lever and turn the rod in or out of the brake swivel **B** as needed.

**NOTE:** The brake should initially be adjusted so that the brake rod extends through swivel **B** approximately 3/4" as shown. If more brake pressure is required adjust as necessary. Swivel **B** should be installed in the inner most hole for floating decks.

3. Reassemble brake rod to the brake lever using hairpin **A**.
4. Apply parking brakes and try to push the machine forward. If wheels rotate, readjust brakes.
5. Close bypass valves on the hydraulic pumps.

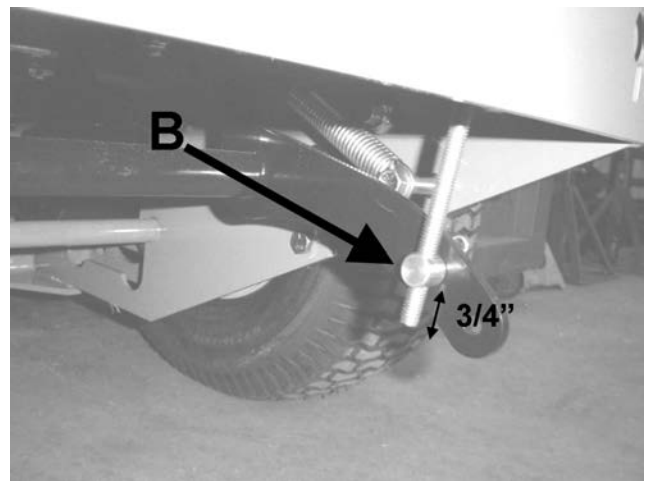
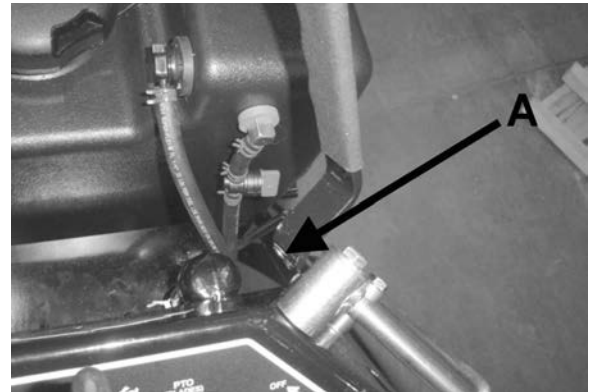

Make all adjustments with the engine shut off, spark plug wire disconnected and mower drive disengaged.

## OPERATOR PRESENT CONTROLS

The operator present (OP) controls should be adjusted to control the operation of the plunger of the operator present switch (located under the right side of the control panel). Depressing OP levers **F** should depress the plunger; releasing the levers should extend it.

### TO ADJUST:

1. Loosen clamp bolts on both ends **G** so clamps can rotate on shaft.
2. Rotate actuator lever to depress switch plunger. Keep OP levers against handles and tighten bolts **G**.
3. When released, the OP levers should rise and the actuator lever should rotate away from the switch, allowing the switch plunger to extend completely.

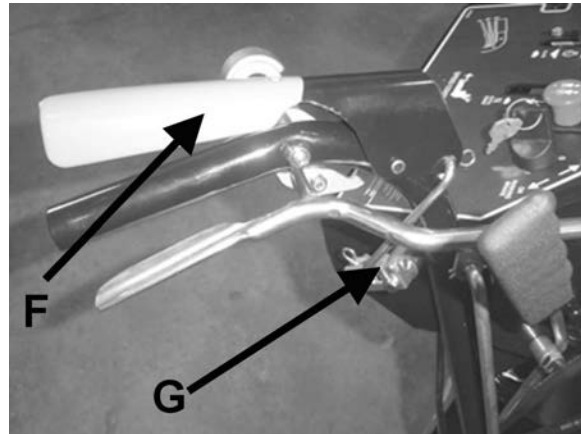

## HANDLE BAR HEIGHT ADJUSTMENT

To adjust handle bar height: Remove bolts **G** and loosen bolts **E** on each side of handlebars. Raise or lower as required. Reposition upper handle and reinsert bolts **G** into appropriate hole in lower handle and tighten. Readjust traction control rods, brakes and parking brakes.

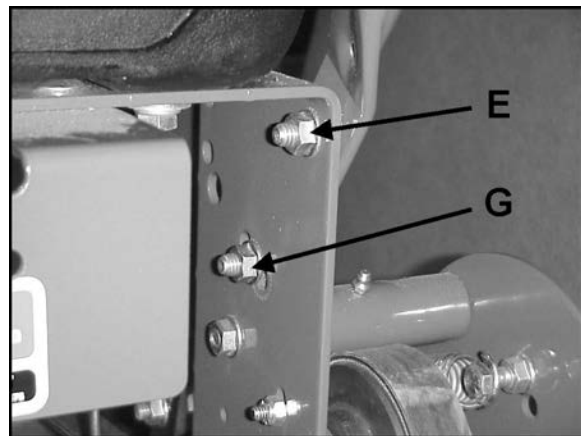

## Speed Control Lever Friction

The speed control lever is held where set by friction pads. If the setting will not hold, tighten nuts **E** to increase friction on the speed control lever.

Adjust Knob **D** to get machine to track in a straight line.

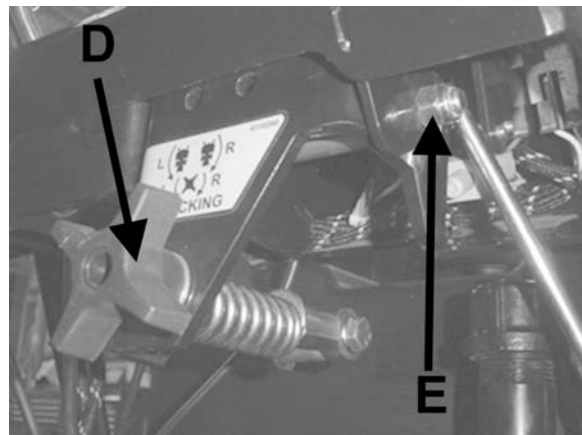

**TRACTION DRIVE HYDROSTAT ADJUSTMENTS:** The following adjustments must be done in order.

## STEP 1 - Set Neutral

Neutral is set at the factory. If it should require adjustment, raise the wheels off the ground by setting the machine on jackstands or blocks. Disconnect the traction control rod **A** and speed control rod **R** at each pump end. Disconnect pump arm spring **U** from bolt on engine deck. Loosen bolt **S** securing the neutral plate eccentric shaft just enough to turn the shaft. Start the engine and run at low speed. Turn eccentric shaft **T** to raise or lower the point at which the follower bearing is held in the center of the "V" until the wheels stop turning. Tighten the eccentric shaft bolt. Increase the throttle setting and check the adjustment. Readjust if necessary. Shut the engine off before proceeding to steps 2 and 3.

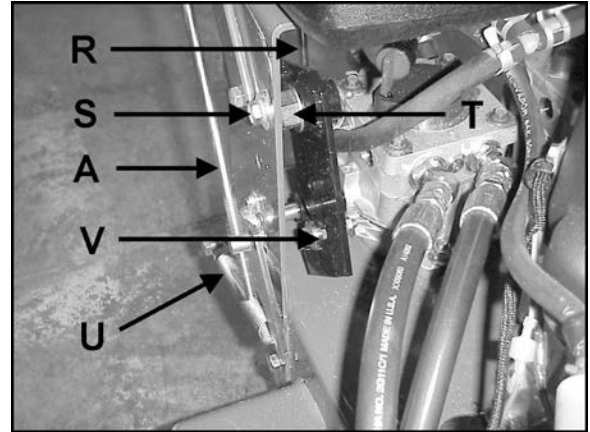

## STEP 2 - Adjust Speed Control Rods

First adjust neutral, as outlined in Step 1. Set speed control levers to neutral. Adjust swivels on lower ends of speed control rods **R** so they just go into top of the slots on the neutral plates.

**NOTE:** If the speed control levers do not have adequate tracking adjustment, the swivel on one of the rods needs to be turned 1 turn.

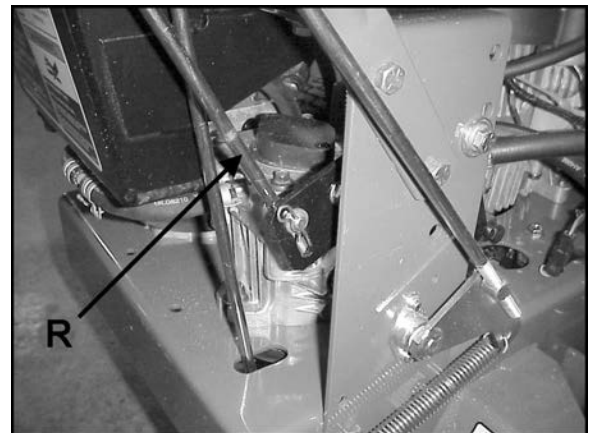

## STEP 3 - Adjust Traction Levers

Set neutral and adjust speed control rods as outlined in Steps 1 and 2. Set traction locks in the neutral position. Grasp traction rod **A** and pull down on it to take out any slack. The pump control arm has some back and forth play. Adjust the swivel to the center of the control arm play. Connect the swivel to the control arm. Reattach pump arm spring **U** to bolt on engine deck.

**NOTE:** More reverse speed may be gained by adjusting the swivel to the rear of the control arm play. A minimum of 1/16" play is required so the traction controls can be put in neutral without the machine backing up.

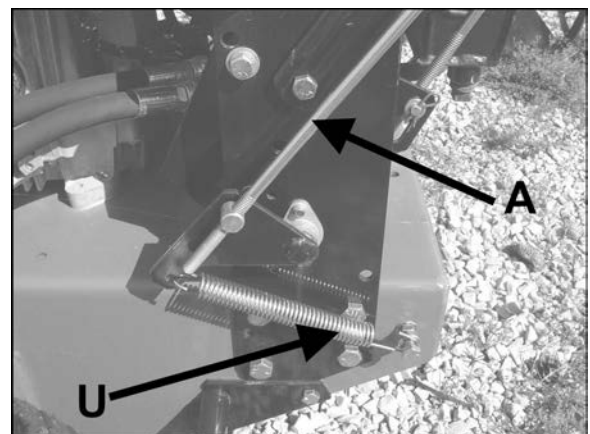

## POWER UNITS

### CONTROLS:

Throttle, choke, PTO switch, speed selector levers, key switch, operator present, traction levers (1 per wheel), parking brake.

### GROUND SPEED:

0-6 mph Forward  
0-2 mph Reverse

### DRIVE TIRES:

18 x 7.50 Turf Saver

### BRAKES:

Hydrostat provides dynamic braking  
Parking brake: Mechanical on tire surface

### TRANSMISSION DRIVE SYSTEM:

Belt from engine to hydrostat input shafts, hydrostatic drive to wheels.

### TURNING RADIUS:

inside wheel 0".

### HYDRAULIC RESERVOIR CAPACITY:

1.2 Gallons

### POWER STEERING:

Independently controlled drive wheels.

## CUTTERDECKS

### CONSTRUCTION:

10 and 7 gauge steel deck welded single unit, baffled for high velocity air flow, large discharge opening with chute guard deflector.

### SPINDLES:

1" spindle shaft on maintenance free sealed ball bearings in precision machined housing.

### CASTERS:

11 x 4.00

### HEIGHT OF CUT:.

adjustable from 1-1/4" to 5"

### BLADE DRIVE:

industrial b section heavy duty v-belt drive (not twisted) from crankshaft to cutterdeck with 5" steel idlers on sealed ball bearings. pto switch on control panel controls engagement of blades..

### BLADE MATERIAL:

1566 alloy steel, austempered and heat treated.

## ACCESSORIES AVAILABLE

Standup Sulky  
Jumbo Grasscatcher  
Eco-plate  
Mulch Kit



<b>SIDE DISCHARGE DECKS</b>			
<b>MODEL NUMBER</b>	<b>936600</b>	<b>936601</b>	<b>936602</b>
<b>WIDTH (CHUTE DOWN)</b>	47" (1194 mm)	66.75" (1696 mm)	64" (1854 mm)
<b>WIDTH (CHUTE UP)</b>	48.25" (1225 mm)	54" (1372 mm)	62.38" (1584 mm)
<b>WIDTH OF CUT</b>	35.25" (895 mm)	47.25" (1200 mm)	52.5" (1336 mm)
<b>NUMBER OF BLADES</b>	2	3	3
<b>BLADE LENGTH</b>	18" (457 mm)	16.25" (413 mm)	18" (457 mm)
<b>BLADE TYPE</b>	High Lift (Low Lift option)	High Lift (Low Lift option)	High Lift (Low Lift option)
<b>BLADE THICKNESS</b>	0.205" (5.2 mm)	0.205" (5.2 mm)	0.205" (5.2 mm)
<b>TIP SPEED</b>	16965 ft/min (5171 m/min)	15315 ft/min (4668 m/min)	16965 ft/min (5171 m/min)
<b>DAILY PRODUCTION @ 5 mph (8 km/hr)</b>	14.2 acres/8hrs (5.74 ha/8hrs)	19.0 acres/8hrs (7.4 ha/8 hrs)	21.1 acres/8hrs (8.6 ha/8hrs)
<b>SHIPPING WEIGHT</b>	236 lbs (107 kg)	270 lbs (122 kg)	326 lbs (148 kg)

<b>ENGINES</b>			
<b>MODEL NUMBER</b>	936600	936601	936602
<b>MANUFACTURER</b>	Kawasaki	Kawasaki	Kawasaki
<b>MODEL</b>	FX541V	FX600V	FX651V
<b>CYLINDERS</b>	2	2	2
<b>COOLING</b>	Air	Air	Air
<b>FUEL</b>	Gasoline	Gasoline	Gasoline
<b>BORE/STROKE</b>	2.9 X 2.8 (73 X 72 mm)	2.9 X 2.8 (73 X 72 mm)	3.1 X 3.0 (78 X 76 mm)
<b>DISPLACEMENT</b>	36.8 ci (603 cc)	36.8 ci (603 cc)	44.3 ci (726 cc)
<b>COMPRESSION</b>	8.1:1	8.1:1	8.2:1
<b>OUTPUT POWER</b>	Refer to engine manufacturer's specifications and website.		
<b>OUTPUT TORQUE</b>	32.1 ft-lb (43.5 N·m) @2000 rpm	32.5 ft-lb (44.1 N·m) @2200 rpm	39.0 ft-lb (52.9 N·m) @2200 rpm
<b>OIL CAPACITY</b>	1.8 qt (1.7L)	1.8 qt (1.7L)	1.8 qt (1.7L)
<b>LUBRICATION</b>	Full Pressure	Full Pressure	Full Pressure
<b>GOVERNOR</b>	Mechanical	Mechanical	Mechanical
<b>AIR CLEANER</b>	Dual Element	Dual element	Dual Element
<b>IGNITION SYSTEM</b>	Electronic	Electronic	Electronic
<b>CHARGING SYSTEM</b>	15 Amp Regulated	15 Amp Regulated	15 Amp Regulated
<b>BATTERY</b>	BCI U1	BCI U1	BCI U1

# **PARTS SECTION**

# UPPER ENGINE DECK ASSY

# Hydro Midsize

FIGURE 1

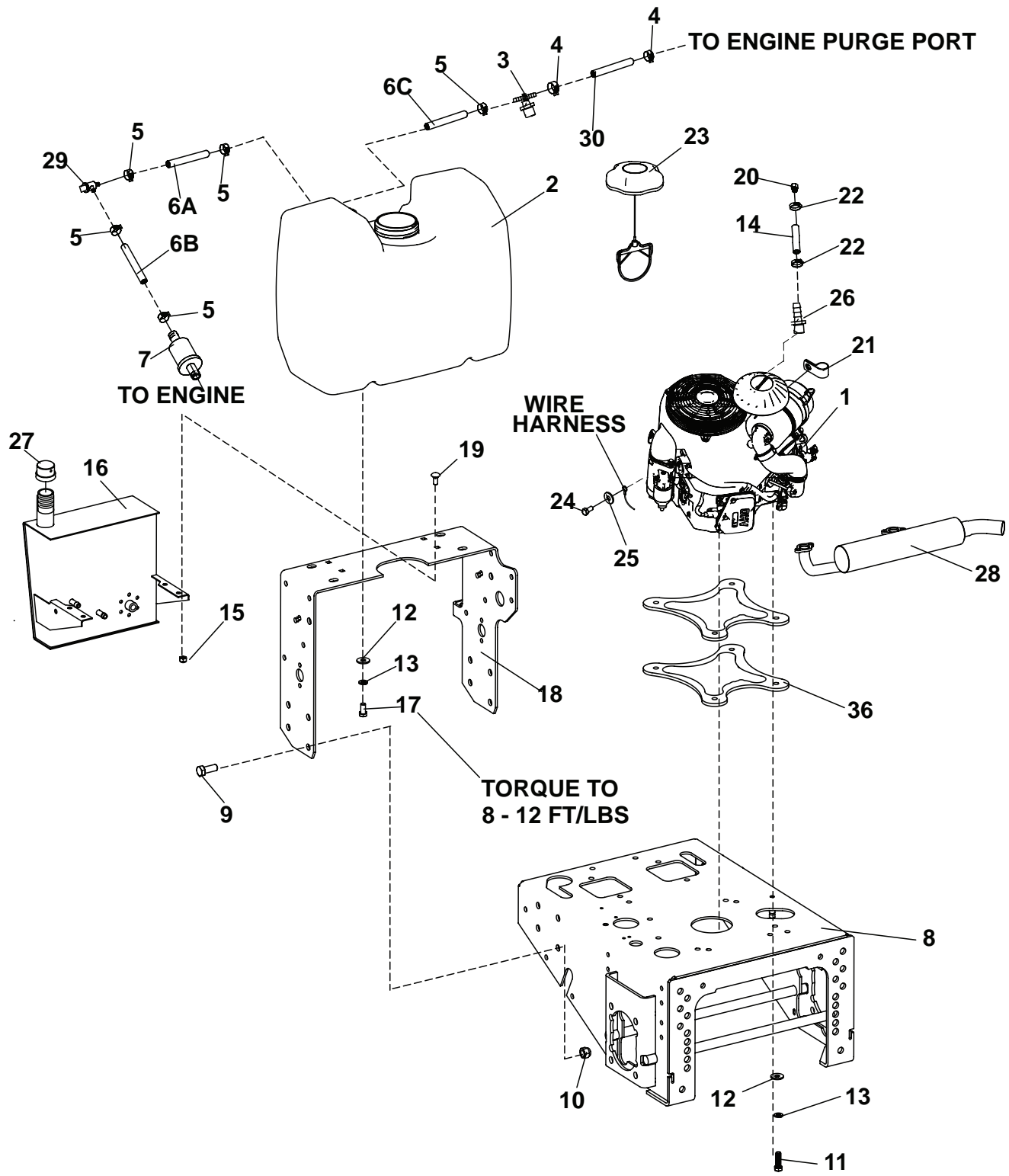

## FIGURE 1

ITEM	PART NO.	DESCRIPTION	QTY	ITEM	PART NO.	DESCRIPTION	QTY
1	4164364	ENGINE-FX541V KAW	1	17	64123-15	BLT-HEX 3/8-16X3/4	4
	4164365	ENGINE-FX600V KAW	1	18	4169109.7	HANDLE-LOWER P-GRIP	1
	4168368	FILTER-FUEL		19	64018-9	BLT-CRG 5/16-18 X 3/4	4
	4164537	FILTER-OIL		20	4164251	VALVE-OIL DRAIN	1
	4164629	FILTER-AIR		21	48412	CLIP-J CABLE 5/8X8.74	1
	4164366	ENGINE-FX651V KAW	1	22	88042-03	CLAMP--HOSE	2
	4168368	FILTER-FUEL		23	4167989	CAP-FUEL GASOLINE 3.5	1
	4164630	FILTER-AIR		24	64205-018	BLT MET M8-1.25X15	1
	4164631	FILTER-SAFETY		25	64002-04	LOCKWASHER, EXT. 5/16	1
	4164537	FILTER-OIL		26	4164252-001	FITTING-3/8NPT-3/8 BARB	1
2	4165561	TANK-FUEL (INCLUDES ITEMS 23, 31-35)	1	27	69216.7	CAP-RESERVOIR	1
				28	4169248	MUFFLER-MIDSIZE (USED ON 936600 AND 936601)	1
					4169247	MUFFLER-ENGINE (USED ON 936602)	1
3	4169746	VENT-FUEL, IN-LINE	1	29	4163016	VALVE-FUEL	1
4	88042-01	CLAMP-HOSE 3/16	2	30	4162989-001	HOSE-FUEL	1
5	88042N	HOSE CLAMP	4	31*	4132325	GROMMET-FUEL TANK	1
6	4162977-001	HOSE,FUEL LINE 56" 6A CUT TO 2" 6B CUT TO 18.5" 6C CUT TO 34.5"	1	32*	4165387	GROMMET-ROLLOVER VNT	1
				33*	4165763	VENT-FUEL TANK	1
				34*	4165668	FILTER-FUEL IN TANK	1
				35*	4165667	FITTING-BARB	1
				36	4169420.2	PLATE-ENGINE SPACER	2
7	4168368	FILTER, FUEL	1	<b>*NOT ILLUSTRATED</b>			
8	4169053.2	WLDMT-DECK,ENGINE	1				
9	64123-39	BOLT-HEX 1/2-13X1-1/4	8				
10	64229-05	LOCKNUT, 1/2-13 NYLON	8				
11	64123-87	BLT-HEX 3/8-16X1-3/4	4				
12	64163-31	WASHER	8				
13	64006-03	LOCKWSHR-HELICAL 3/8	8				
14	69053-03	HOSE-HYDR 3/8X17"	1				
15	64229-02	LOCKNUT-NYLON 5/16-18	4				
16	2306127	S-HYD RESEVOIR W/LABS (INCLUDES ITEM 27)	1				

# LOWER ENGINE DECK ASSY/CLUTCH

Hydro  
Midsized

FIGURE 2

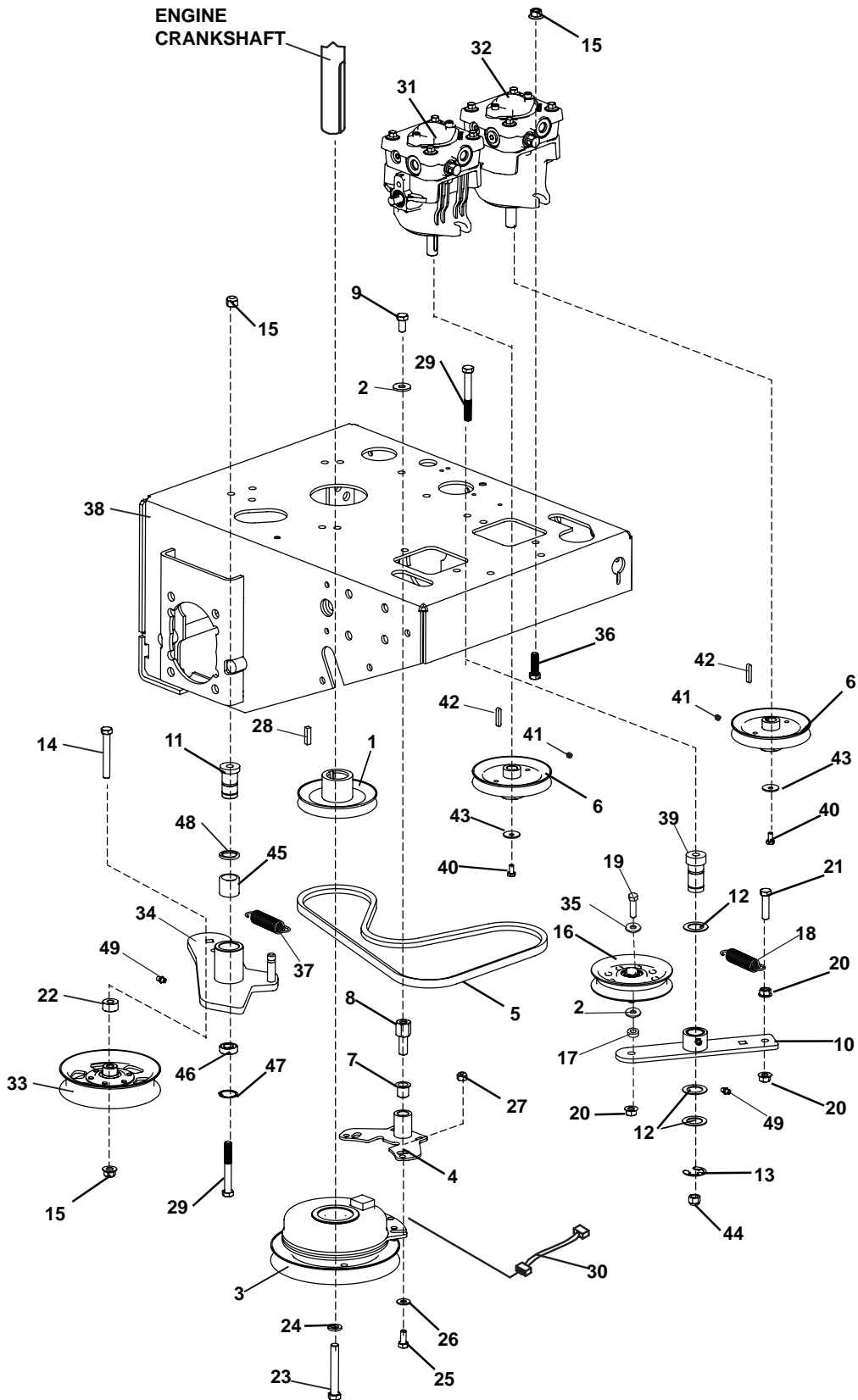

### FIGURE 2

ITEM	PART NO.	DESCRIPTION	QTY	ITEM	PART NO.	DESCRIPTION	QTY
1	4169536	PULLEY-4.50E.O.D.	1	33	4168078	PULLEY-IDLER, SPLIT	1
2	64163-31	WASHER, 25/64 X 1 X 12	3	34	4169474	ASSY-IDLER ARM,PTO	1
3	4169649	CLUTCH-175 LB (INCLUDES ITEM 30)	1			(INCLUDES ITEMS 45-48)	
4	4167232.7	WLDMT-CLUTCH STOP	1	35	64163-61	WSHR .81X.406X16GA	1
5	2721642	BELT-HA 49.0	1	36	64123-16	BLT-HEX 3/8-16X1-1/4	4
6	2722244	PULLEY- A SECTION 4.50	2	37	4163586	SPRING-EXTENSION	1
7	38304-03	BRG-FLANGED PLASTIC	1	38	4169053.2	WLDMT-DECK,ENGINE	1
8	4121540	PIN-CLUTCH	1	39	4116691	PIN-PIVOT	1
9	64123-15	BOLT-3/8-16X3/4 HEX	1	40	64205-013	BLT-MET M6-1 X 12	2
10	2721641.7	WLDMT-IDLER ARM	1	41	64044-6	SCREW-SET 5/16-18X1/4	4
11	4116661	PIN-PIVOT	1	42	64238-03	KEY-MET 5MM SQ X 28	2
12	64163-65	WASHER 0.890 X 1.375	3	43	64209-09	WASHER-CONICAL SPRING	2
13	64221-04	E-RING.875	1	44	64229-03	LOCKNUT-NYLON 3/8-16	1
14	64123-88	BLT-HEX 3/8-16X2-3/4	1	45	548138	BRG NDL.88 1.12 1.00	1
15	64268-03	NUT-FL NYL LOCK 3/8-16	6	46	4128004	BEARING-BALL 10 X 26 X 8	1
16	2308000	PULLEY-IDLER 4.00 EOD	1	47	64144-40	SNAP RING-26MM INTRNL	1
17	33148-01	SPACER	1	48	521438	GREASE SEAL	1
18	38219	SPRING-TENSION	1	49	85010N	ZERK 1/4-28 STR SELF TAP	2
19	64123-87	BLT-HEX 3/8-16 X 1-3/4	1				
20	64141-4	NUT-WLF 3/8-16	3				
21	64123-70	BOLT-HEX 3/8-16X1-1/2	1				
22	33030-07	BUSHING IDLER	1				
23	64123-78	BLT-HEX 7/16-20X2-1/2	1				
24	64006-06	LOCKWSHR-HELICAL 7/1	1				
25	64123-54	BOLT, 5/16-18X3/4 HEX	2				
26	64163-55	WASHER .328X.75X14 GA	2				
27	64229-02	LOCKNUT-NYLON 5/16-18	2				
28	64164-12	1/4X1/4X1 SQ END KEY	1				
29	64123-75	BOLT, 3/8-16X3 HEX	2				
30	2720949	ASSY-CLUTCH WIRE	1				
31	4163316	PUMP-HYDRO LH	1				
32	4163317	PUMP-HYDRO RH	1				

**FIGURE 3**

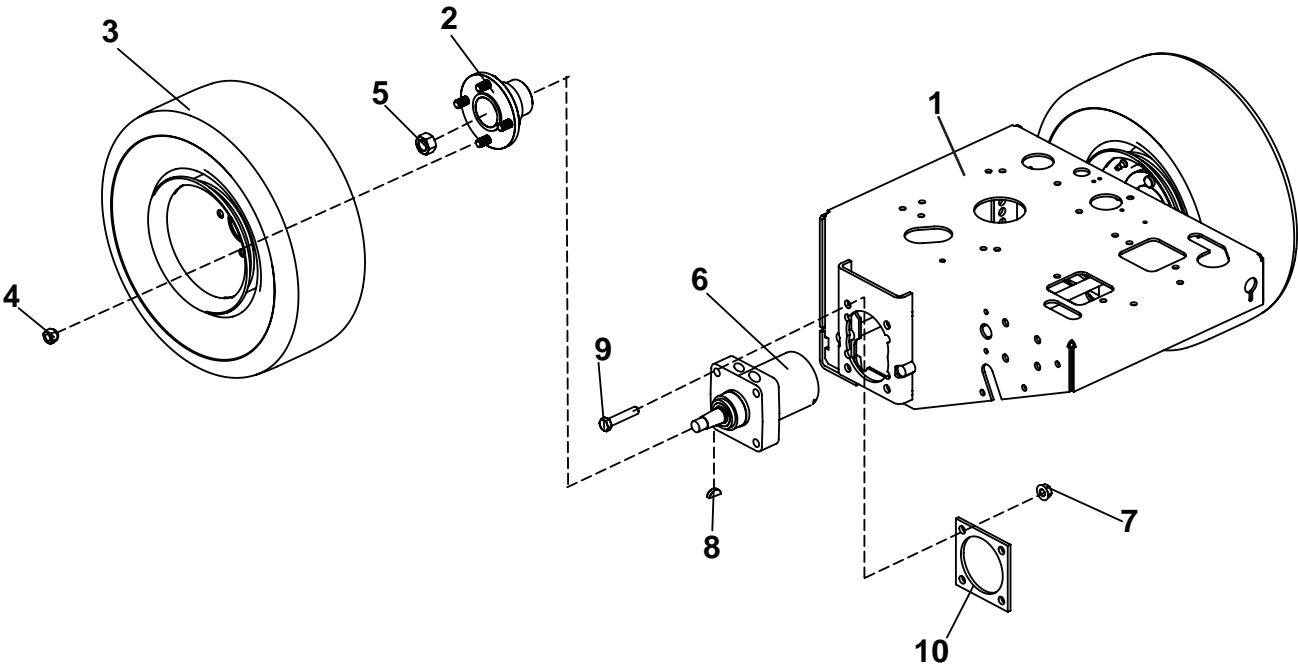



## FIGURE 3

ITEM	PART NO.	DESCRIPTION	QTY	ITEM	PART NO.	DESCRIPTION	QTY
1	4169053.2	WLDMT-DECK,ENGINE	1				
2	2721620	WLDMT-HUB	2				
*	970438	KIT-WHEEL HUB PULLER					
3	4169435	WHEEL-ASSY, 18 X 7.5	2				
	4169435-01	WHEEL-18X7.5	2				
	4169435-02	TIRE-18X7.5	2				
4	64187-03	NUT-WHEEL 1/2-20	8				
5	64025-06	NUT-HEX 3/4-16 2A	2				
6	2308051	MOTOR-WHEEL ROSS MF	2				
7	64141-13	NUT WLF 1/2-13	8				
8	64164-28	#808 WOODRUFF KEY	2				
9	64123-72	BLT-HEX 1/2-13X2-1/2	8				
10	4169059.2	PLATE-MOTOR CLAMP	2				

**\*NOT ILLUSTRATED**

# PARKING BRAKE/DOCUMENT TUBE

## Hydro Midsize

FIGURE 4

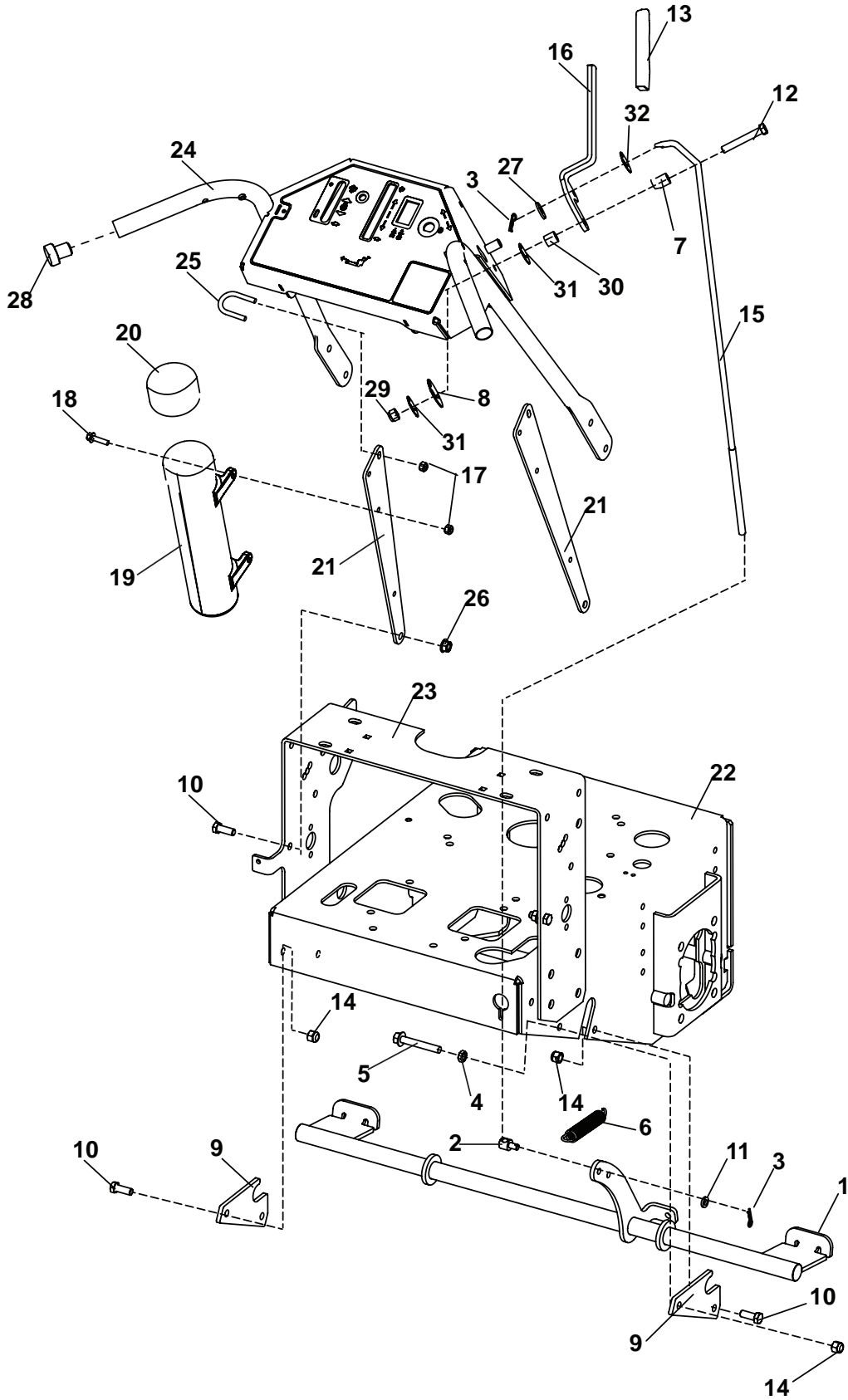

FIGURE 4

ITEM	PART NO.	DESCRIPTION	QTY	ITEM	PART NO.	DESCRIPTION	QTY
1	4169790.7	WLDMT-SHAFT,BRAKE	1				
2	33103	SWIVEL	1				
3	64168-2	COTTER-HAIRPIN.08X1.19	2				
4	64001-6	NUT-HEX JAM,3/8-16	1				
5	64262-025	BLT-FLG HD 3/8-16 X 2-1/2	1				
6	2188131	SPRING-EXTENSION	1				
7	2183071-01	SPACER-15.88X10.32X16	2				
8	64171-2	WAVE WASHER	1				
9	4131072.7	PLATE-BRK SHFT RETNR	2				
10	64123-50	BOLT-HEX 3/8-16X1	5				
11	64163-02	WSHR-.325 X .596 X 11GA	1				
12	64123-82	BOLT-HEX 3/8-16X2-1/2	1				
13	38404-03	GRIP-CONTROL LEVER	1				
14	64229-03	LOCKNUT-NYLON 3/8-16	5				
15	4169140	ROD-PARK BRAKE	1				
16	4169216.7	LEVER-BRAKE	1				
17	64229-01	LOCKNUT-NYLON 1/4-20	4				
18	64262-003	BLT-FLG HD 1/4-20 X 1	2				
19	4129802	TUBE-DOCUMENT	1				
20	38061A	CAP-DOCUMENT TUBE	1				
21	4169353.7	BRACE-HANDLE	2				
22	4169053.2	WLDMT-DECK,ENGINE	1				
23	4169109.7	HANDLE-LOWER,HYDRO	1				
24	4169404	WLDMT-UPPER HANDLE	1				
25	64225-03	U-BOLT	2				
26	64141-4	NUT-WLF 3/8-16	2				
27	64163-95	WSHR-.344X.688X.065	1				
28	4169945	PLUG-PLASIC	2				
29	64268-03	NUT-FL NYLON LOCK 3/8-16	1				
30	33030-07	BUSHING IDLER	1				
31	4169895	WASHER-FRICTION,UHMW	2				
32	64163-46	WSHR.383/.393X.88X7GA	1				

# UPPER HANDLE

# Hydro Midsize

FIGURE 5

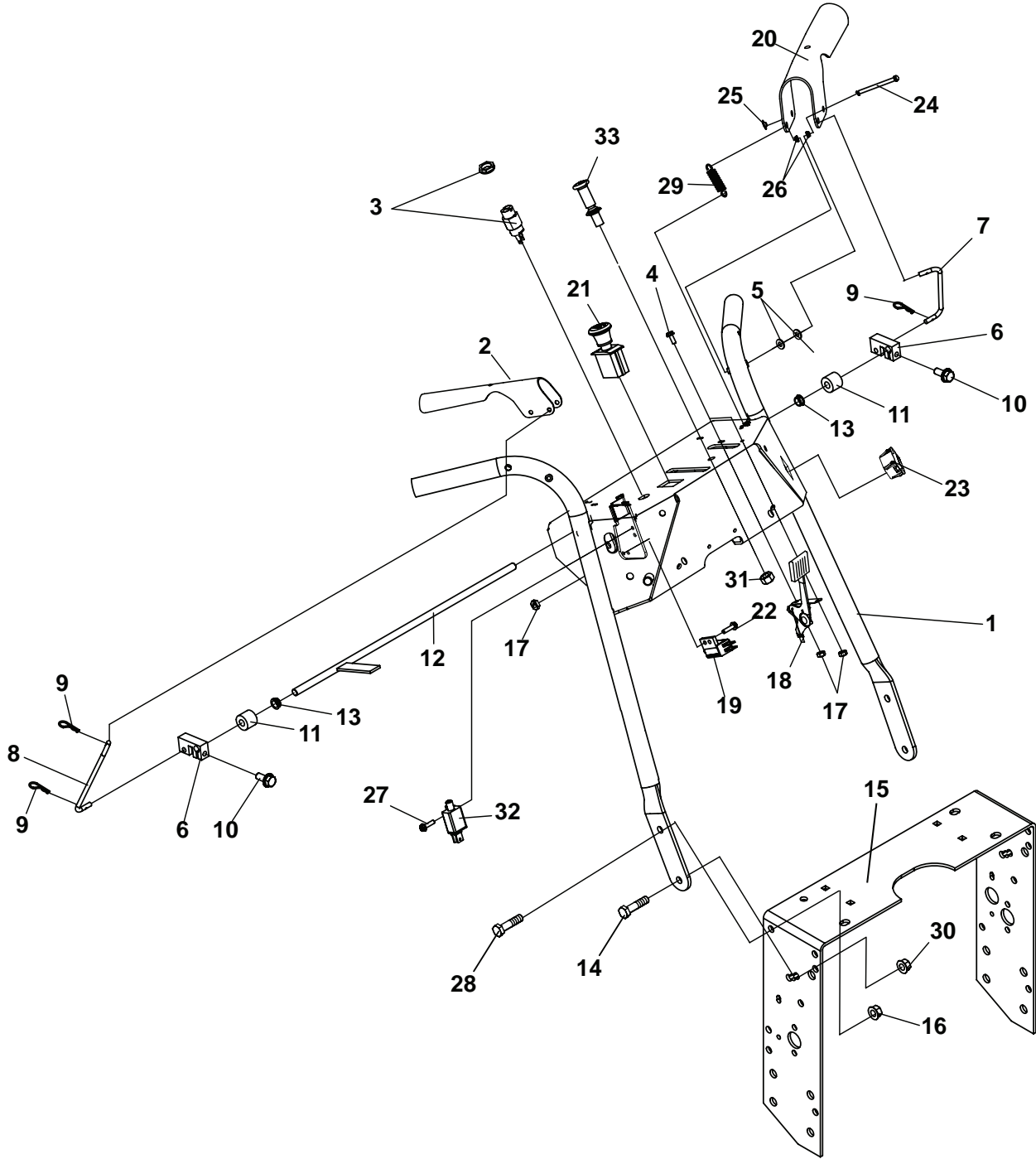

## FIGURE 5

ITEM	PART NO.	DESCRIPTION	QTY	ITEM	PART NO.	DESCRIPTION	QTY
1	4169404	S-UPPR HNDL W/LABELS (USED ON ELECTRIC START MODELS)	1				
2	4169316.7	HNDL-OPER PRESENT, RH	1				
3	128010	SWITCH-ENGINE`	1				
4	64152-46	SCR-SLT HH 10-24X1/2	2				
5	64163-60	WSHR.50X.203X18GA	4				
6	2303023	CONNECTOR-OP	2				
7	4122104	ROD-HANDLE LINK, LH	1				
8	4122107	ROD-HANDLE LINK, RH	1				
9	64168-2	COTTER-HAIRPIN.08X1.19	4				
10	64197-002	BLT-TDFM 1/4-20X3/4	2				
11	33030-09	IDLER-BUSHING	2				
12	4122056	WLDMT-OP PRESENCE	1				
13	38371-01	BRG-NYLINER 3/8	2				
14	64123-50	BOLT-HEX 3/8-16X1	2				
15	4169109.7	HANDLE-LOWER P-GRIP	1				
16	64141-4	NUT-WLF 3/8-16	2				
17	64025-15	NUT-HEX #10-24 KEPS	4				
18	38357-09	CONTROL-THROTTLE	1				
19	2308094	SWITCH-NCNC DBL POLE	2				
20	4169315.7	HNDL-OP PRESENT	2				
21	2721505	SWITCH-PTO	1				
22	64152-49	SCRW-SLT HH #10-24X3/4	2				
23	4165120	METER-HOUR, W/ALERTS	2				
24	64188-05	PIN-CLEVIS, .19 X 1.75 LG	2				
25	64175-01	PUSHNUT-3/16 ROD	2				
26	38371-03	BRG-NYLINER 3/16	4				
27	64197-015	BLT-TDFM 10-32X1/2	2				
28	64123-70	BLT-HEX 3/8-16X1-1/2	2				
29	2308065	SPRING-TENSION	2				
30	64268-03	NUT-FL NYLON LOCK 3/8-16	2				
31	64025-04	NUT-HEX 3/8-24	1				
32	108208	SWITCH DBL POLE NC/NO	1				
33	108009-03	CONTROL CHOKE 51"	1				

\* NOT ILLUSTRATED

# TRACTION CONTROLS

# Hydro Midsize

## FIGURE 6

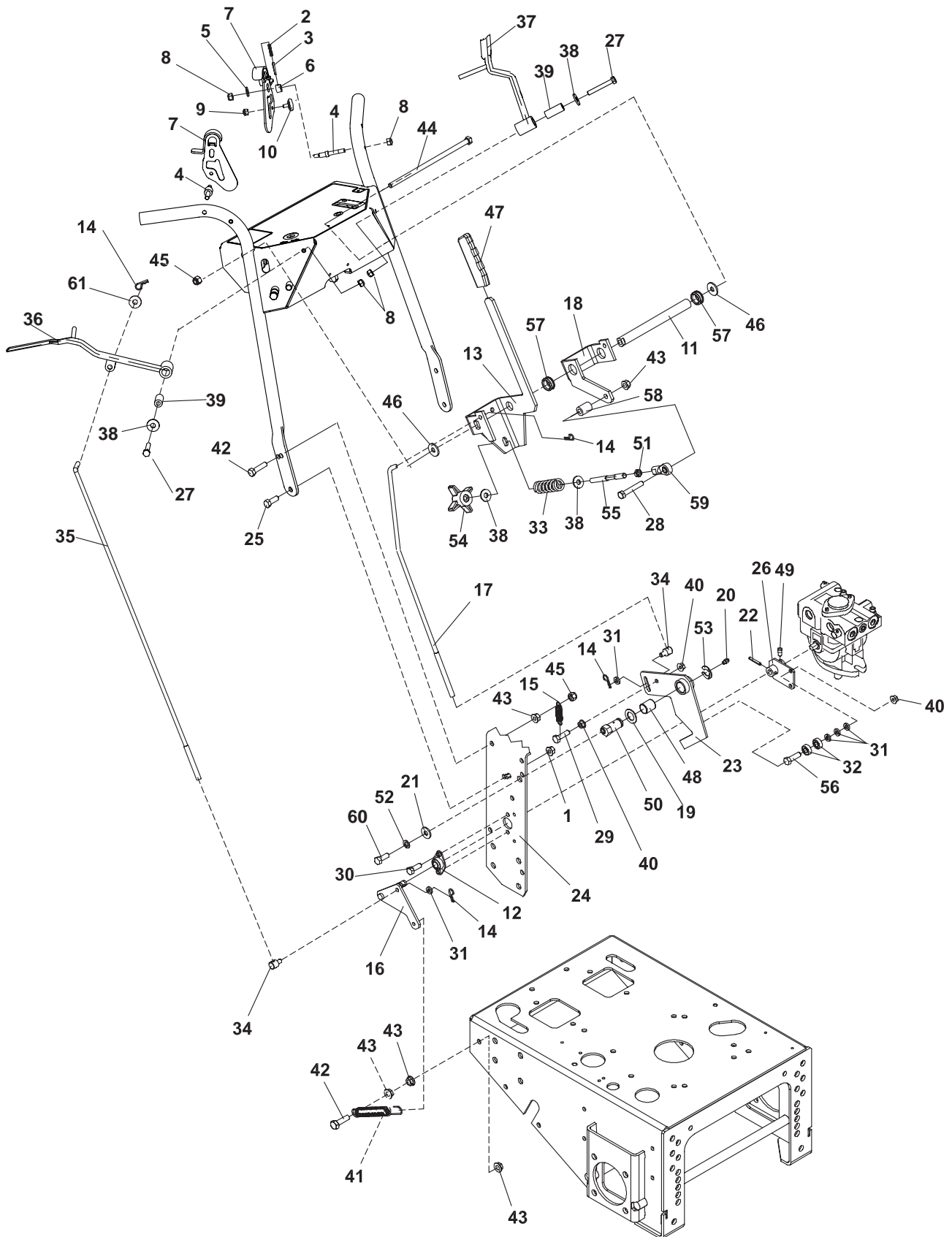

## FIGURE 6

ITEM	PART NO.	DESCRIPTION	QTY	ITEM	PART NO.	DESCRIPTION	QTY
1	64268-03	NUT-FLG LYLOCK 3/8-16	2	42	64123-70	BOLT-HEX 3/8-16X1-1/2	4
2	38189	SPRING-COMPRESSION	2	43	64141-4	NUT-WLF 3/8-16	11
3	64061-37	ROLL PIN-1/8 X 1.00 SS	2	44	64123-202	BLT-HEX 3/8-16 X 9	1
4	2303076	STUD-DOUBLE ENDED	2	45	64229-03	NUT-NYLOCK 3/8-16	3
5	62464-5A	WASHER, THRUST 5/16X3/4	2	46	2308066	FRICTION WASHER	2
6	33243	SPACER	2	47	38404-03	GRIP, CONTROL LEVER	1
7	4168054	LATCH-ROLLER LH HYDRO	1	48	2308076-02	BEARING-PLASTIC	2
	4168055	LATCH-ROLLER RH HYDRO	1	49	64192-04	SET SCREW 5/16-18X5/8	2
8	64229-02	5/16-18 NYLON LOCKNUT	6	50	2303058	ECCENTRIC SHAFT W/ZRK	2
9	64229-01	LOCKNUT NYL 1/4-20	2	51	64001-2	NUT 3/8-16	1
10	2308002	BRG-RADIAL W/THD STUD	2	52	64006-03	WASHER, 3/8 HELICL LCK	2
11	2721844	BUSHING-SPEED CONTROL	1	53	64144-16	RING, CLIP-.75X.062	2
12	2308080	BEARING SELF ALIGNED	2	54	38524	KNOB-4 PRONG 3/8-16	1
13	2721843.7	ARM-RH SPEED CONTROL	1	55	2721854	STUD-3/8-16X 3/8-24 4.5LG	1
14	64168-2	HAIRPIN COTTER	8	56	64123-69	BOLT-5/16-18X1-1/2 HEX	2
15	2308065	SPRING EXTENSION	2	57	118047-09	BUSHING-FLIP LOK.75ID	2
16	2721660.7	WLDMT-PUMP ARM RH	1	58	33030-08	BUSHING-IDLER7/8X3/8X1	1
	*2721622.7	WLDMT-PUMP ARM LH	1	59	138011	BALL JOINT	1
17	2722305	ROD-SPEED CONTROL	2	60	64123-02	BLT-HEX 3/8-24X1	1
18	2721842.7	ARM-LH SPEED CONTROL	1	61	64163-04	WSHR 25/64X5/8X16GA	2
19	64163-06	WSHR.768/.756X1.25X14GA	2				
20	85010N	ZERK, 1/4-28 STR	2				
21	64163-61	WSHR .81X.406X16GA	2				
22	64061-28	ROLL PIN 3/16 X 1 1/4	2				
23	2721617.7	WLDMT-SPEED CONTROL	2				
24	4169109.7	HANDLE-LOWER P-GRIP	1				
25	64123-50	BOLT, 3/8-16X1 HEX	2				
26	2306081.7	WLDMT PUMP ARM	2				
27	64123-64	BLT-HEX 5/16-18X2-1/4	2				
28	64123-100	BOLT-3/8-16X2-1/4 HEX	1				
29	64123-68	BLT-HEX 5/16-18 X 1	2				
30	64139-13	BLT-WLF 5/16-18X1/2	4				
31	64163-02	WSHR 21/64X19/32X11 GA	10				
32	38372	BEARING BALL	4				
33	2720312	SPRING-COMP IDLER PLT	1				
34	33103	SWIVEL	4				
35	4168050	ROD-TRCTN CNTRL, HYDRO	2				
36	4169224	HANDLE-RH	1				
37	4169223	HANDLE-LH	1				
38	64163-31	WASH 25/64X1X12 GA	2				
39	4169218	TUBE-PIVOT	2				
40	64141-6	NUT-WLF 5/16-18	6				
41	4117212	SPRING EXTENSION	2				

\* NOT ILLUSTRATED

# ELECTRIC START BATTERY

# Hydro Midsize

## FIGURE 7

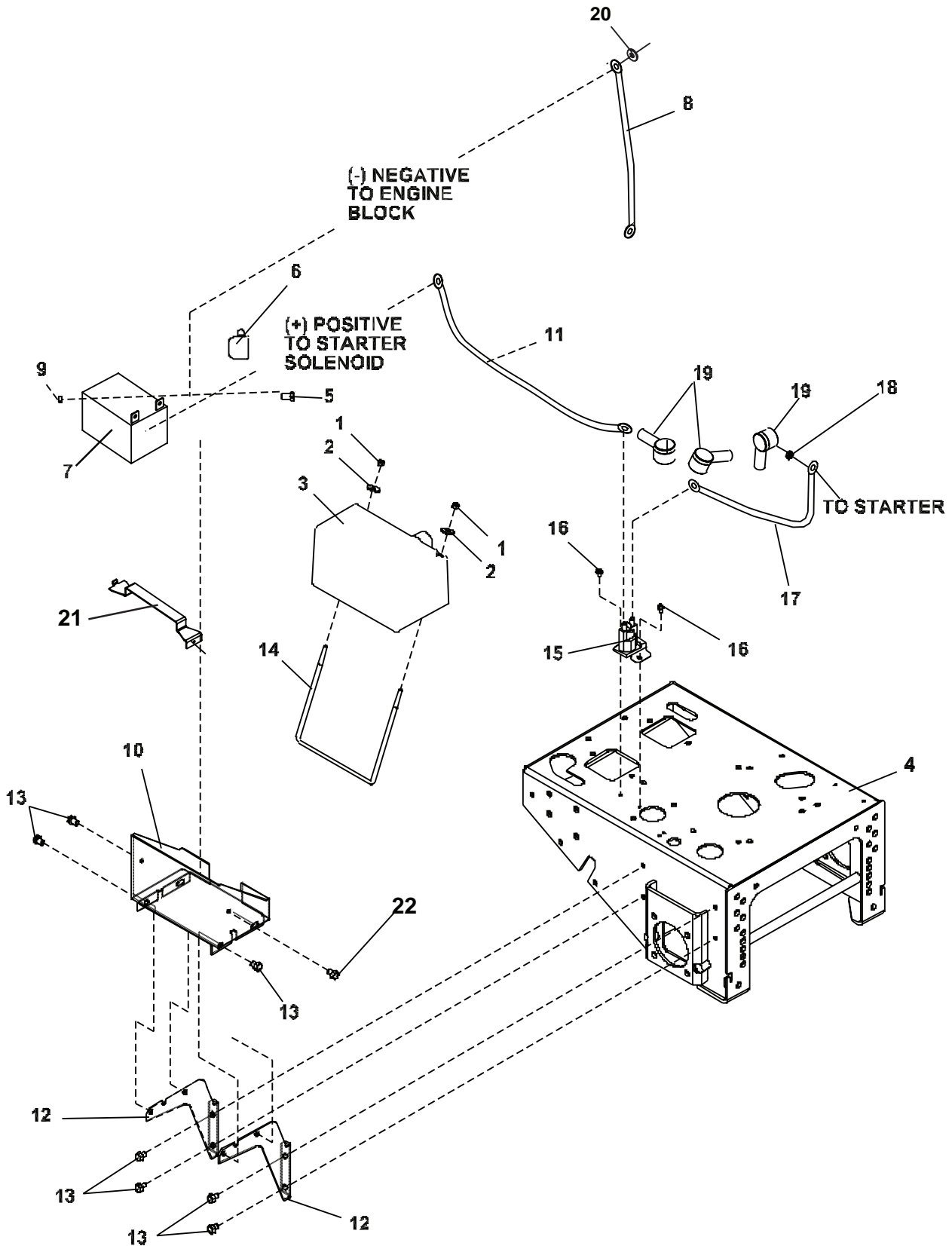



ITEM	PART NO.	DESCRIPTION	QTY	ITEM	PART NO.	DESCRIPTION	QTY
1	64229-02	LOCKNUT-NYLON 5/16-18	2				
2	64163-29	WASHER	2				
3	128035	COVER-BATTERY	1				
4	4169053.2	DECK-ENGINE HYDRO	1				
5	64262-002	BLT-FLG 1/4-20 X 3/4	2				
6	112386	BOOT-BATTERY TERM POS	1				
7	4171099	BATTERY	1				
*	4171973	CHARGER-BATTERY, AGM					
8	108061-16	CABLE-BTTRY 31.5 BLACK	1				
9	64025-01	NUT-HEX 1/4-20	2				
10	4113741	S-TRAY, BATTERY	1				
11	2722227-03	CABLE-BTTRY W/CONDUIT	1				
12	2722202.7	SUPPORT-BATT TRAY	2				
13	64197-016	BLT-TDFM 3/8-16X1/2	8				
14	4168907	ROD,BATTERY HLD DWN	1				
15	38665	SOLENOID (USED ON 936602 ONLY)	1				
16	64152-23	1/4-20X3/8 LG SP SCREW (USED ON 936602 ONLY)	2				
17	108061-15	CABLE-BATTERY 6.5 RED	1				
18	64141-2	NUT-WLF 1/4-20	1				
19	2308095	COVER, TERMINAL	3				
20	64163-03	WSHR-.256X.62X18GA	2				
21	4168764.7	STRAP-BATTERY	1				
22	64152-56	SCREW-HS STAP #12 X 1/2	1				

FIGURE 8

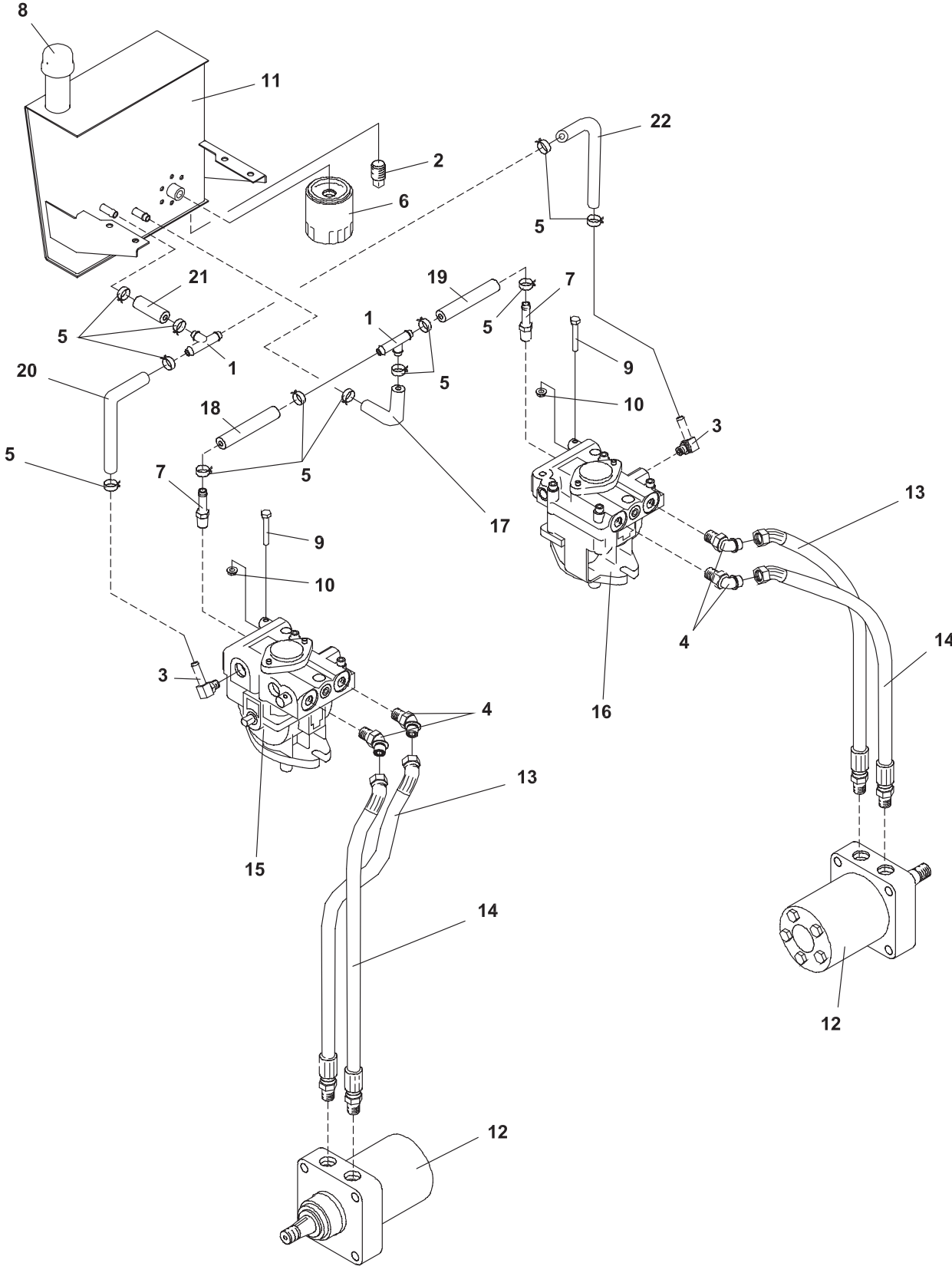

## FIGURE 8

ITEM	PART NO.	DESCRIPTION	QTY
1	58026-01	3-WAY CONNECTOR	2
2	108029	PLUG, MAGNETIC	1
3	158058-04	FITTING-90 BARB, ADJ.	2
4	108205-02	ELBW-MALE 45 8X8 37-ORB	4
5	88042-04	CLAMP-HOSE 5/8"	12
6	2720396	FLTR, 25 MCRN SM CAM	1
7	69060-01	FTG-BARB 9/16 X 3/8 ST	2
8	69216.7	CAP-RESERVOIR	1
9	64123-60	BOLT, 1/4-20X2 HEX	2
10	64229-01	LOCKNUT-NYLON 1/4-20	2
11	2306127	S HYD RESER W/LABS	1
12	2308051	MOTOR WHEEL ROSS	2
13	2692300-01	HOSE-1/2 37/ORB X 18.5 LG	2
14	2692300-02	HOSE-1/2 37/ORB X 20.5 LG	2
15	4163317	PUMP-HYDRO RH (SEE FIG 16 FOR PARTS BREAKDOWN)	1
16	4163316	PUMP-HYDRO LH (SEE FIG 16 FOR PARTS BREAKDOWN)	1
(69053-05 IS A SERVICEABLE LENGTH OF 55")			
17	69053-05	3/8 HI TEMP HOSE 17.0"	1
18	69053-05	3/8 HI TEMP HOSE 5.0"	1
19	69053-05	3/8 HI TEMP HOSE 5.0"	1
20	69053-05	3/8 HI TEMP HOSE 7.5"	1
21	69053-05	3/8 HI TEMP HOSE 6.8"	1
22	69053-05	3/8 HI TEMP HOSE 12.0"	1

### SERVICEABLE HYDRAULIC O-RINGS

SAE PORT 'O' RING		
PART NUMBER	THREAD SIZE	AS-568#
158061-10	9/16-18	-906
158061-11	3/4-16	-908
158061-12	7/8-14	-910
158061-13	1-1/16-12	-912
158061-14	1-5/16-12	-916
158061-16	1-5/8-12	-920
158061-03	1-7/8-12	-924

**NOTE:**  
**DO NOT** use teflon tape on any hydraulic fittings.  
 Use a liquid pipe sealant.

# CASTER ASSY

# Hydro Midsize

FIGURE 9

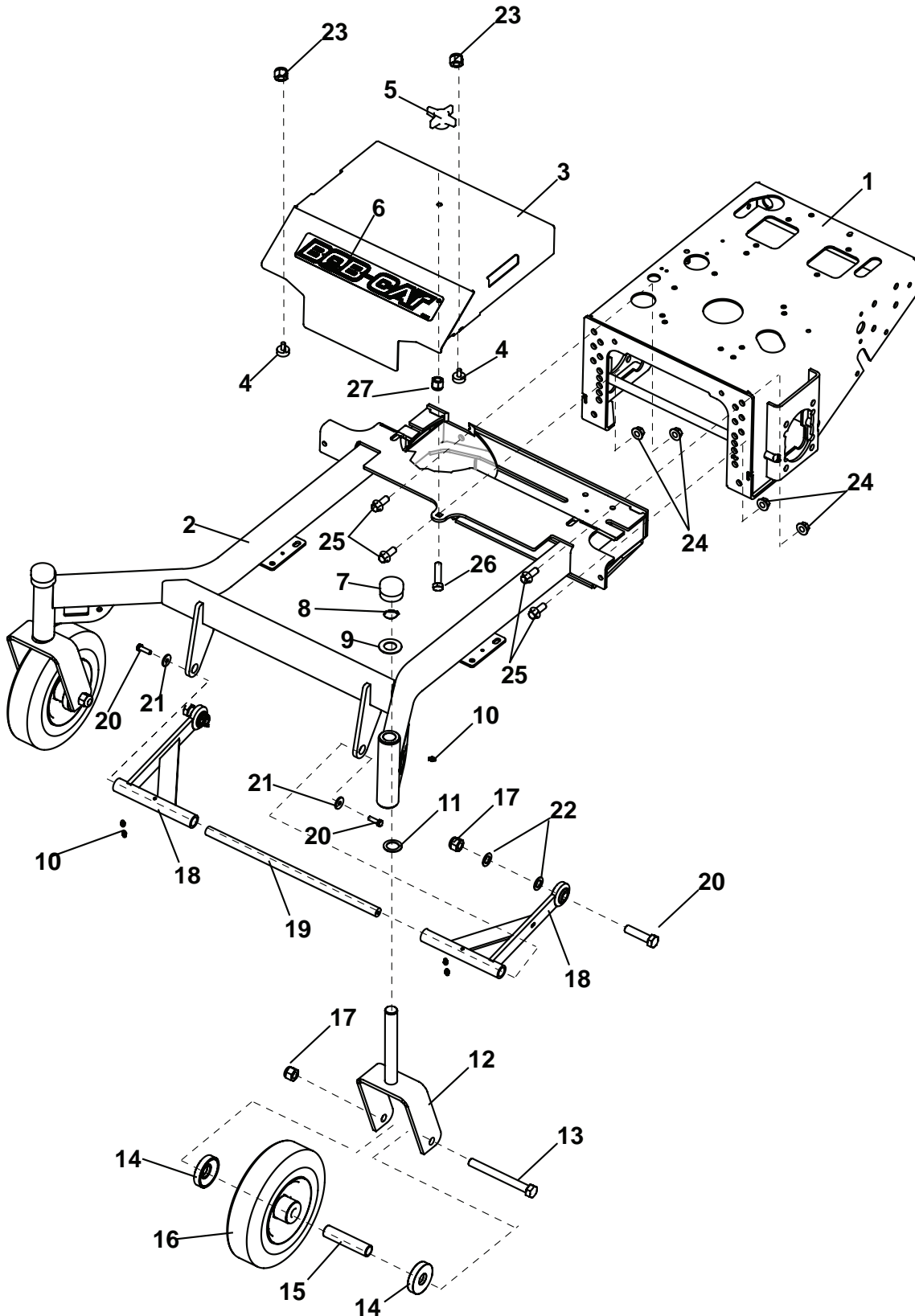

## FIGURE 9

ITEM	PART NO.	DESCRIPTION	QTY	ITEM	PART NO.	DESCRIPTION	QTY
1	4169053.2	WLDMT-DECK,ENGINE	1				
2	4169074.7	WLDMT-FRONT CRADLE,48"&52"	1				
	4169172.7	WLDMT-FRONT CRADLE 61"					
3	4169862.2	COVER-BELT 48&52,CNTR	1				
	4169863.2	COVER-BELT 61", CNTR					
4	4143354	BUMPER SEAT MOUNTING	2				
5	38524	KNOB-4 PRONG 3/8-16	1				
6	4164406	LABEL-BOB-CAT	1				
7	4168439	CAP-YOKE SHAFT/HUB	2				
8	64144-24	SNAP RING 1.00 EXT	2				
9	64163-112	WSHR-1.015 X 1.860 X 14GA	2				
10	85010N	ZERK 1/4-28 STR SELF TAP	6				
11	64163-64	WSHR 1.015X1.500X14GA	2				
12	4169125.7	WLDMT-CASTER	2				
13	64123-212	BLT-HEX 5/8-11X6	2				
14	2722231	SPACER-END	4				
15	2722230-01	SPANNER-11IN WHEEL	2				
16	4169203	WHEEL-11 X 4 NO FLAT	2				
17	64229-06	NUT-NYLON LOCK 5/8-11	4				
18	4163957.7	WLDMT-PULL ARM	2				
19	4162973	BAR-PULLARM PIVOT	1				
20	64123-168	BLT-HEX 5/8-11 x 2 1/2	4				
21	64163-29	WSHR-21/64 X 1 X 11GA	1				
22	64163-93	WSHR-.635 X 1.12 X.062	4				
23	64141-6	NUT-WLF 5/16-18	2				
24	64246-04	NUT-WHIZ M12-1.75	4				
25	64263-018	BLT-FLG HEAD M12-1.75 X 30	4				
26	64018-7	BLT-CRG 3/8-16X1-1/4	1				
27	64141-4	NUT-WLF 3/8-16	1				

**\* NOT ILLUSTRATED**

# HEIGHT OF CUT ASSEMBLY

# Hydro Midsize

FIGURE 10

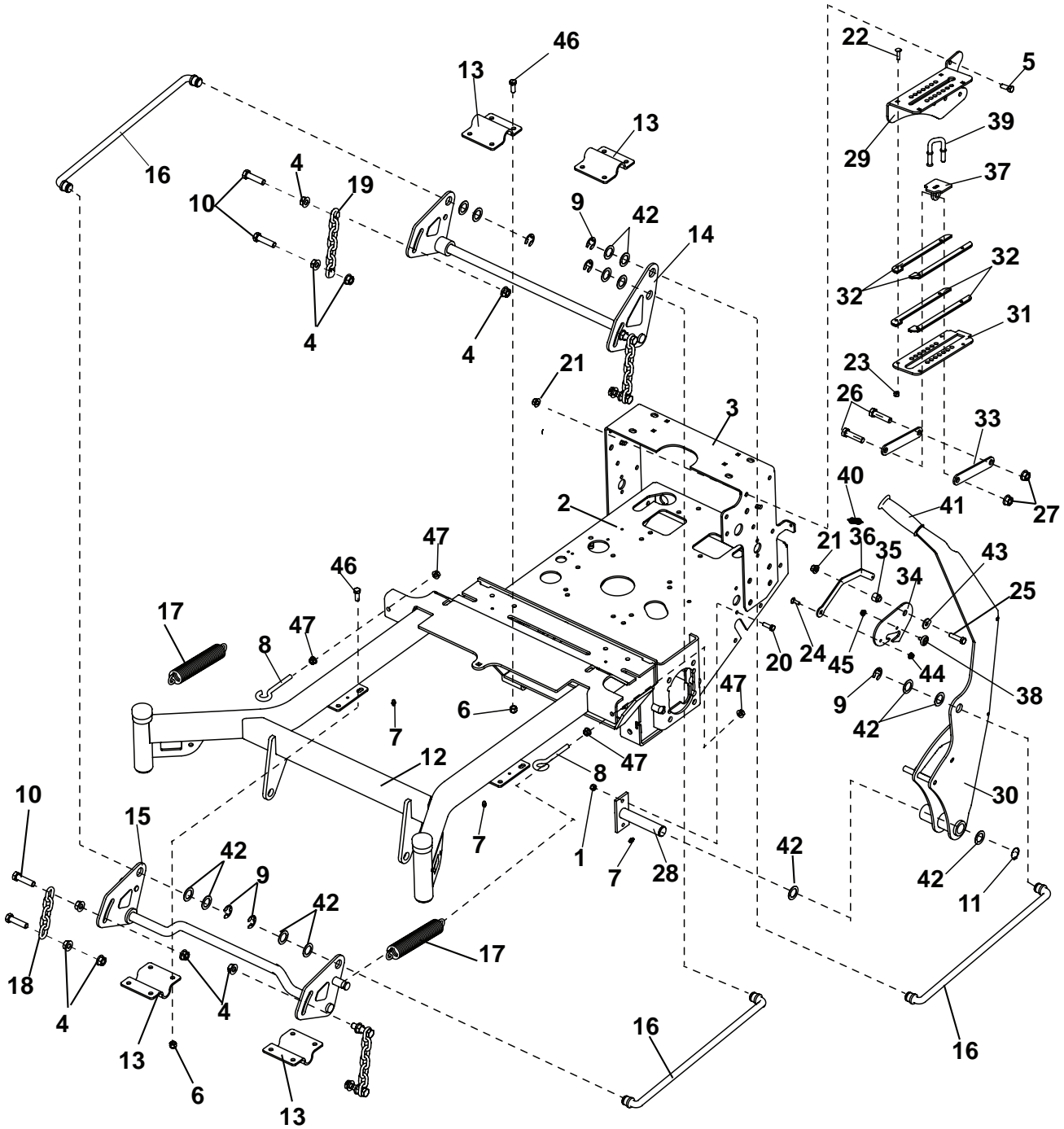

## FIGURE 10

ITEM	PART NO.	DESCRIPTION	QTY	ITEM	PART NO.	DESCRIPTION	QTY
1	64229-02	NUT-NYLON LOCK 5/16-18	2				
2	4169053.2	WLDMT-DECK, ENGINE	1				
3	4169109.7	HANDLE-LOWER, HYDRO P-GRIP	1				
4	64141-13	NUT-WLF 1/2-13	17				
5	64123-50	BLT-HEX 3/8-16X1	4				
6	64229-03	NUT-NYLON LOCK 3/8-16	16				
7	85010N	ZERK-1/4-28 STR SELF THREAD	5				
8	4113682	ROD-SPRING MOUNT	2				
9	64221-04	E-RING .875	6				
10	64123-281	BLT-HEX 1/2-13X2 FULL THREAD	8				
11	64144-24	SNAP RING 1.00 EXT	1				
12	4169074.7	WLDMT-FRONT CRADLE 48 & 52	1				
	4169172.7	WLDMT-FRONT CRADLE 61"					
13	2182356.7	BRACKET-SHAFT HANGER	4				
14	4169095.7	WLDMT-DECK LIFT, REAR	1				
15	4169094.7	WLDMT-DECK LIFT, FRONT	1				
16	4167826	ROD-DECK LIFT	3				
17	4165675	SPRING-DECK LIFT	2				
		(USED ON 48" & 52")					
	2722719	SPRING DECK LIFT					
		(USED ON 61" )					
18	2188127	CHAIN-6.35 (.250) 5 LINKS	2				
19	4169126	CHAIN-ASSEMBLY, 7 LINK	2				
20	64123-68	BLT-HEX 5/16-18X1	3				
21	64268-03	NUT-FL NYLON LOCK 3/8-16	5				
22	64018-42	BLT-CRG 1/4-20 X 1	4				
23	64229-01	NUT-NYLON LOCK 1/4-20	4				
24	64018-2	BLT-CRG 1/4-20X3/4	1				
25	64123-70	BLT-HEX 3/8-16X1-1/2	1				
26	64123-39	BLT-HEX 1/2-13X1-1/4	2				
27	64151-37	NUT-HEX,1/2-13NYLON JAM	2				
28	4169067.2	WLDMT-SHAFT, HOC	1				
29	4169117.7	BRKT-HEIGHT ADJUST	1				
30	4169121.7	WLDMT-HOC HANDLE	1				
31	4169144.7	PLATE-HEIGHT ADJUST	1				
32	4169145.7	SPACER-HEIGHT ADJUST	4				
33	4169146.7	LINK-HEIGHT ADJUST	2				
34	4169147.2	LATCH-TRANSPORT	1				
35	4169169	SPACER-TRANSPORT RELEASE	1				
36	4169663.7	PLATE-LOCK, HOC LATCH	1				
37	4167994.7	WLDMT-HEIGHT ADJ SLIDER	1				
38	2308002	BRG-RADIAL W/THD STUD.75	1				
39	4168338	STOP-WIRE FORM, UPGRADE	1				
40	4164627	SPRING-EXT, .5 X 2.25 X .055	1				
41	522727	GRIP-HANDLE	1				
42	64163-65	WSHR-.890X1.375X18GA	14				
43	64163-31	WSHR 25/64X1X12	1				
44	64268-01	NUT-FL NYLON LOCK 1/4-20	1				
45	64141-2	NUT-WLF 1/4-20	1				
46	64262-011	BLT-FLG HD 3/8-16 X 1	16				
47	64141-4	NUT-WLF 3/8-16	4				

\* NOT ILLUSTRATED

FIGURE 11

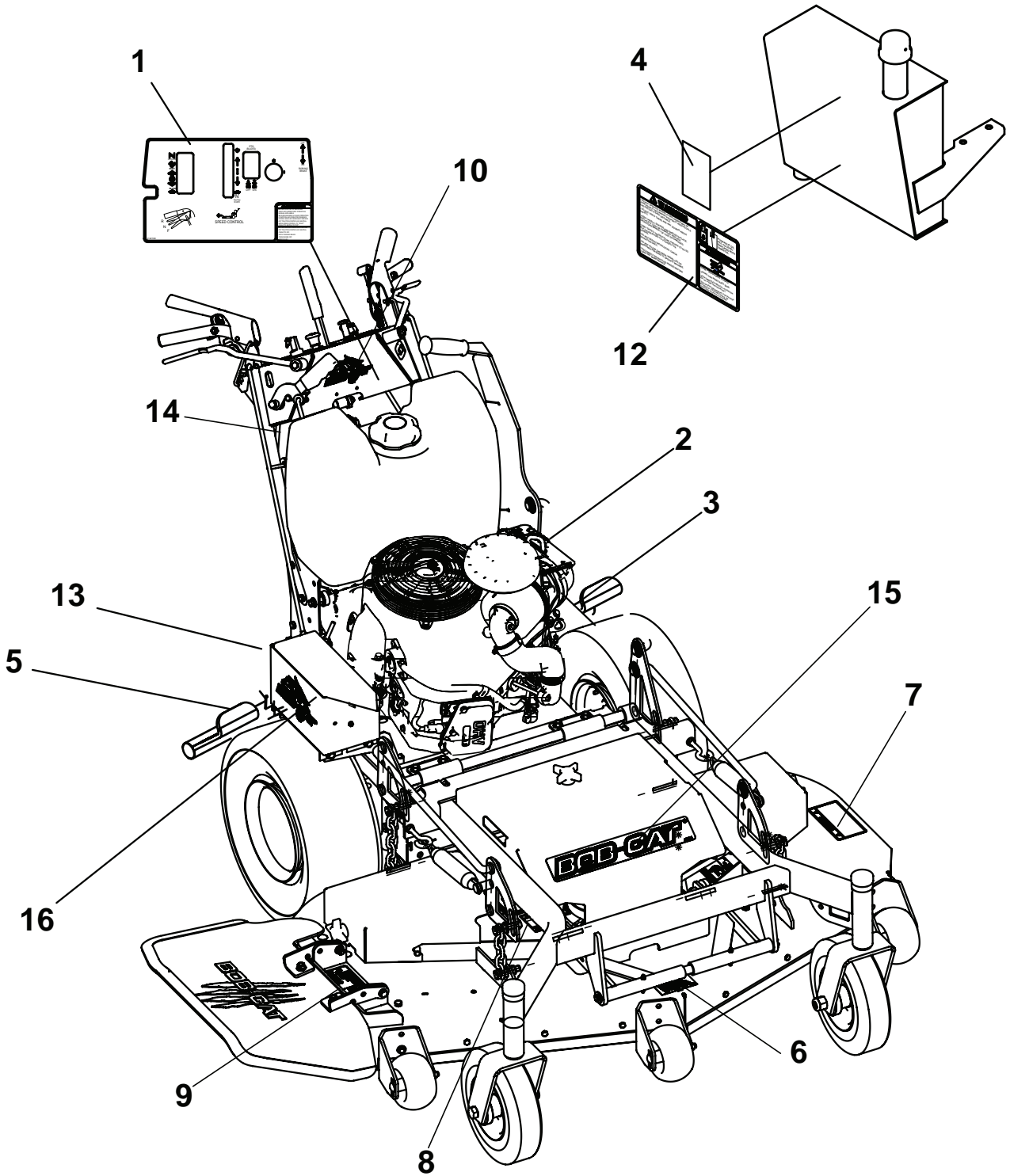



**FIGURE 11**

ITEM	PART NO.	DESCRIPTION	QTY	ITEM	PART NO.	DESCRIPTION	QTY
1	4169239	LABEL-CONTROL PNL HYD	1				
2	4169634	LABEL-HEIGHT OF CUT	1				
3	2000570	LABEL-WARN FUEL PICT	1				
4	340830	LABEL-CAUTION SPANISH	1				
5	2000571	LABEL-IMPORTANT	1				
6	4116761	LABEL-MADE IN USA	1				
7	2000572	LABEL-WARNING BLADES	1				
8	2000577	LABEL-DANGER/WARNING	3				
9	4164269	LABEL-ROT PRTS/B-WSHR (LOCATED UNDER BELT COVER)	1				
10	2000704	LABEL-MIDSIZE PATENT	1				
11*	2000673	LABEL - OP MAN/TIRES (ON DOCDUMENT TUBE)	1				
12	2000661	LABEL-HYD TANK WARN	1				
13	2000590	LABEL-WARNING BATTERY	1				
14*	4110260	LABEL-TRACKING CNTRL	1				
15	4164406	LABEL-BOBCAT	1				
16	4158400	LABEL-BOBCAT, MEDIUM	1				
17	4158402	LABEL-BOBCAT, SMALL	1				
18*	4169490	LABEL-PATENT	1				
19*	4165932	DECAL-EPA	1				

\* NOT ILLUSTRATED

# WIRE DIAGRAM-ELECTRIC START

# Hydro Midsize

FIGURE 12

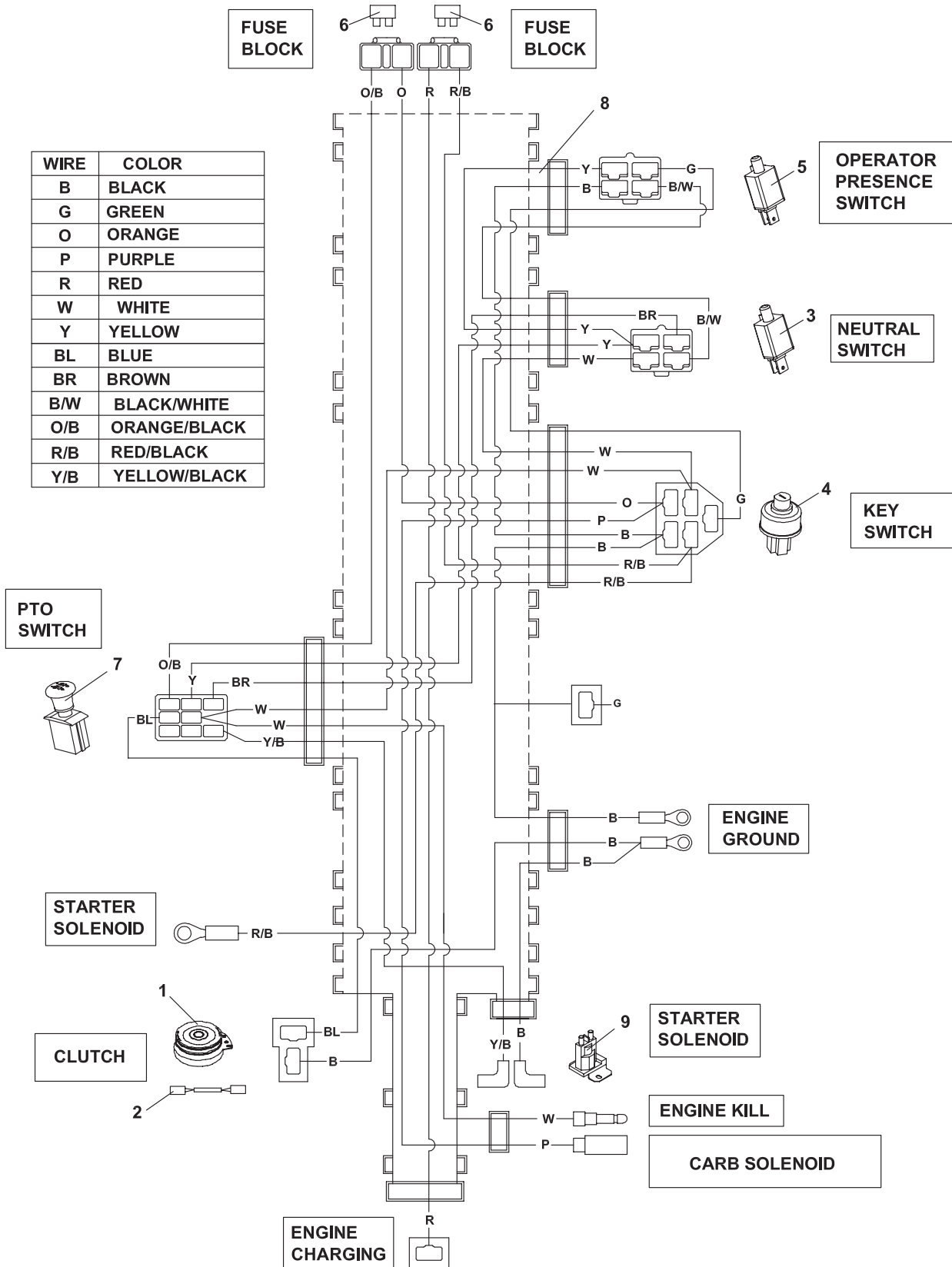

ITEM	PART NO.	DESCRIPTION	QTY	ITEM	PART NO.	DESCRIPTION	QTY
1	4169649	CLUTCH-175 LB (INCLUDES ITEM 2)	1				
2	2720949	ASSY-CLUTCH WIRE	1				
3	108208	SWITCH DBL POLE	1				
4	128010	KEY SWITCH	1				
5	2308094	SWITCH-NCNC DBL POLE	1				
6	148082-20	FUSE 20 AMP	2				
7	2721505	SWITCH-PTO	1				
8	4169406	HARNESS-HYDRO MAIN (INCLUDES QTY OF 2 OF ITEM 6) USED ON 48" & 52" MODELS	1				
	4169884	HARNESS-ELC MAIN USED ON 61" MODEL					
9	38665	SOLENOID-STARTER (USED ON 936602 ONLY)	1				
10*	108061-15	CABLE-BATTERY 6.5 RED (FROM STARTER SOLENOID TO STARTER)	1				
11*	2722227-03	CABLE-BATTERY W/CONDUIT (FROM (+) POSITIVE BATTERY TERMINAL TO STARTER SOLENOID)	1				
12*	108061-16	CABLE-BATTERY 31.5 BLACK (FROM (-) NEGATIVE BATTERY TERMINAL TO ENGINE BLOCK)	1				

**\* NOT ILLUSTRATED**

# WIRING SCHEMATIC-ELECTRIC START

FIGURE 13

REF. 4115550

# Hydro Midsize

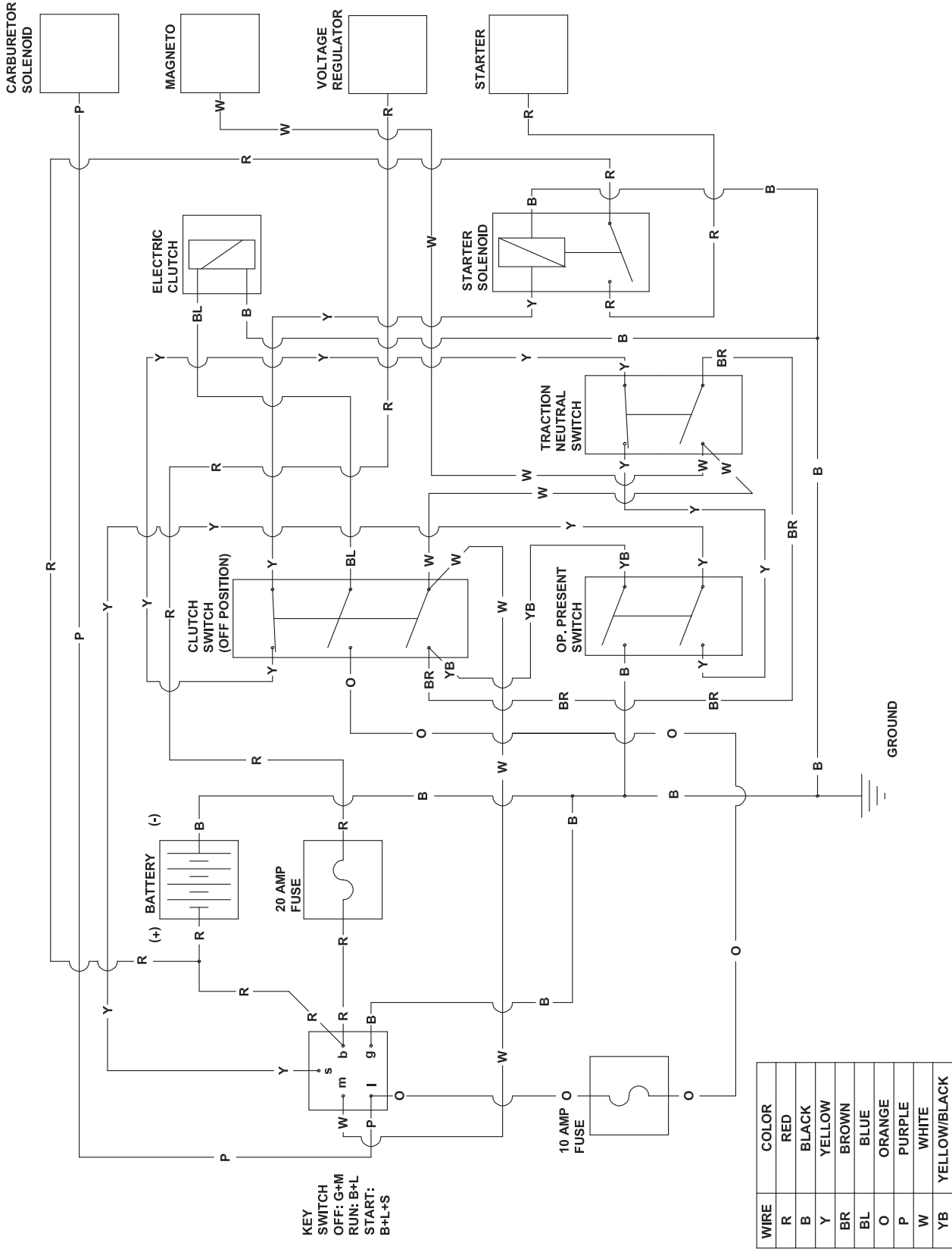

ITEM	PART NO.	DESCRIPTION	QTY	ITEM	PART NO.	DESCRIPTION	QTY
------	----------	-------------	-----	------	----------	-------------	-----

# HYROGEAR PUMP

# Hydro Midsize

FIGURE 14

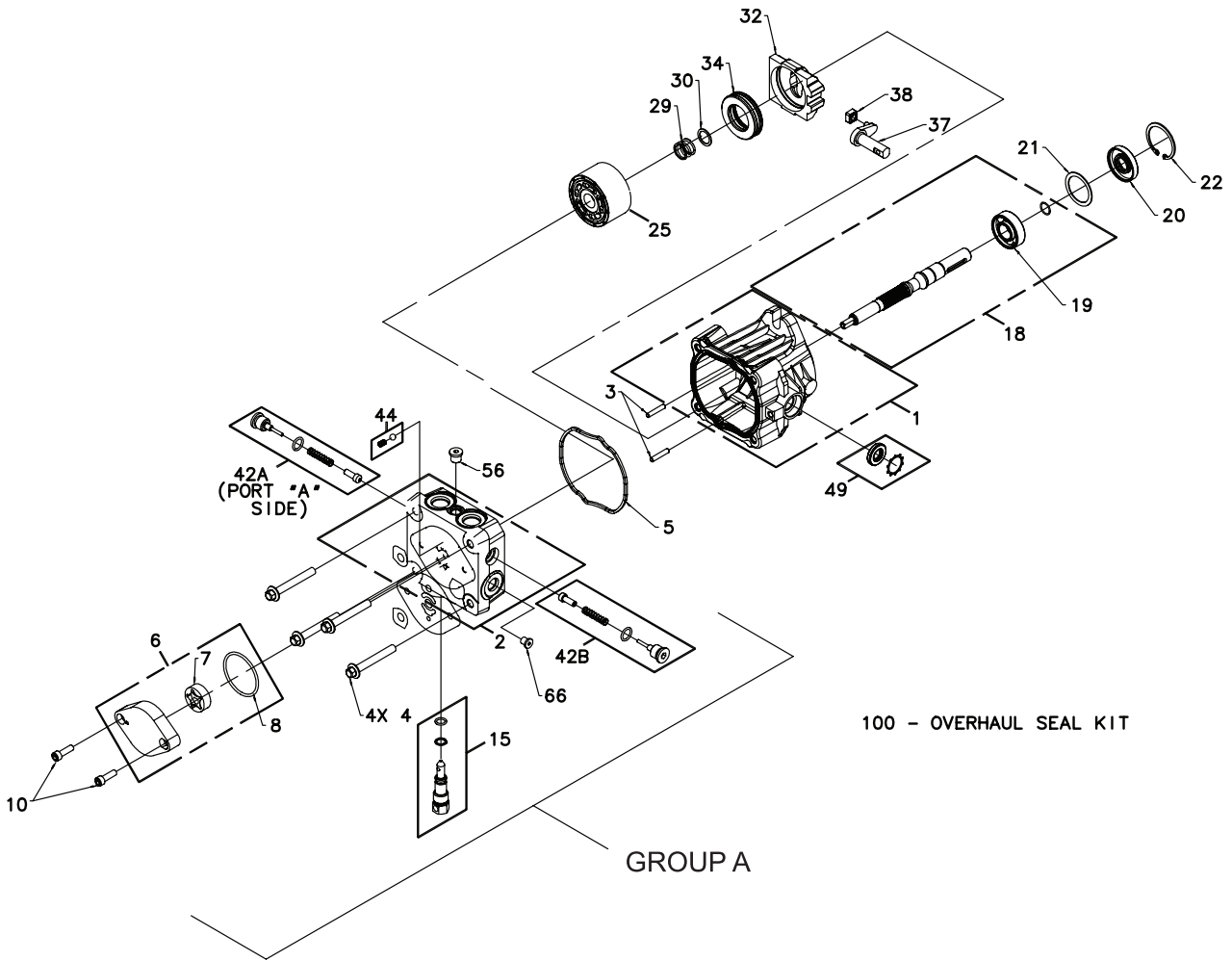

4112782 & 4163317 PUMP-HYDRO RH ILLUSTRATED AS SHOWN  
 2721615 & 4163316 PUMP-HYDRO LH ILLUSTRATED AS SHOWN EXCEPT GROUP A IS ROTATED  
 180° AROUND THE CENTERLINE OF THE PUMP.

ITEM	HYDROGEAR PART NO.	PART NO.	DESCRIPTION	QTY
1	70516	----	HOUSING KIT	1
2	71615	----	END CAP KIT	1
3	50641	----	STRAIGHT HEADLESS PIN	2
4	50969	2721615-01	FLANGE BOLT M8-1.25 X 60	4
5	52629	4161615-02	HOUSIGN O-RING	1
6	2513027	----	CHARGE PUMP KIT (STD)	1
7	50273	----	STD GEROTOR ASSEMBLY	1
8	9004101-1340	----	O-RING	1
10	50975	4163316-02	SOCKET HEAD M6-1/0 X 20	2
15	2513030	----	BYPASS VALVE KIT (BLANK)	1
18	70521	2721615-07	PUMP SHAFT KIT	1
19	50315	----	BALL BEARING 17 X 40 X 12	1
20	51161	----	LIP SEAL 17 x 40 x 12	1
21	50951	----	SPACER	1
22	50329	----	RETAINING RING	1
25	70723	4163316-03	CYLINDER BLOCK KIT	1
29	2003014	----	BLOCK SPRING	1
30	2003017	----	BLOCK THRUST WASHER	1
31	51246	----	VALVE PLATE	1
32	2003087	----	SWASHPLATE	1
34	50551	----	BALL THRUST BEARING	1
37	2003005	----	TRUNNION ARM	1
38	2000015	----	SLOT GUIDE	1
42A	2510027	----	CHECK VALVE KIT (.031")	1
42B	2510050	----	CHECK VALVE KIT (BLANK)	1
44	70402	4163316-04	CHARGE RELIEF VALVE KIT	1
49	2513043	2721615-17	TRUNNION SEAL/RETAINER KIT	1
56	9005110-4400	----	STRAIGHT THREAD PLUG	1
66	9005110-3100	----	5/16 SAE PLUG	1
100	70525	2721615-18	OVERHAUL SEAL KIT	1

# MOUNTING-48" DECK

# Hydro Midsize

## FIGURE 15

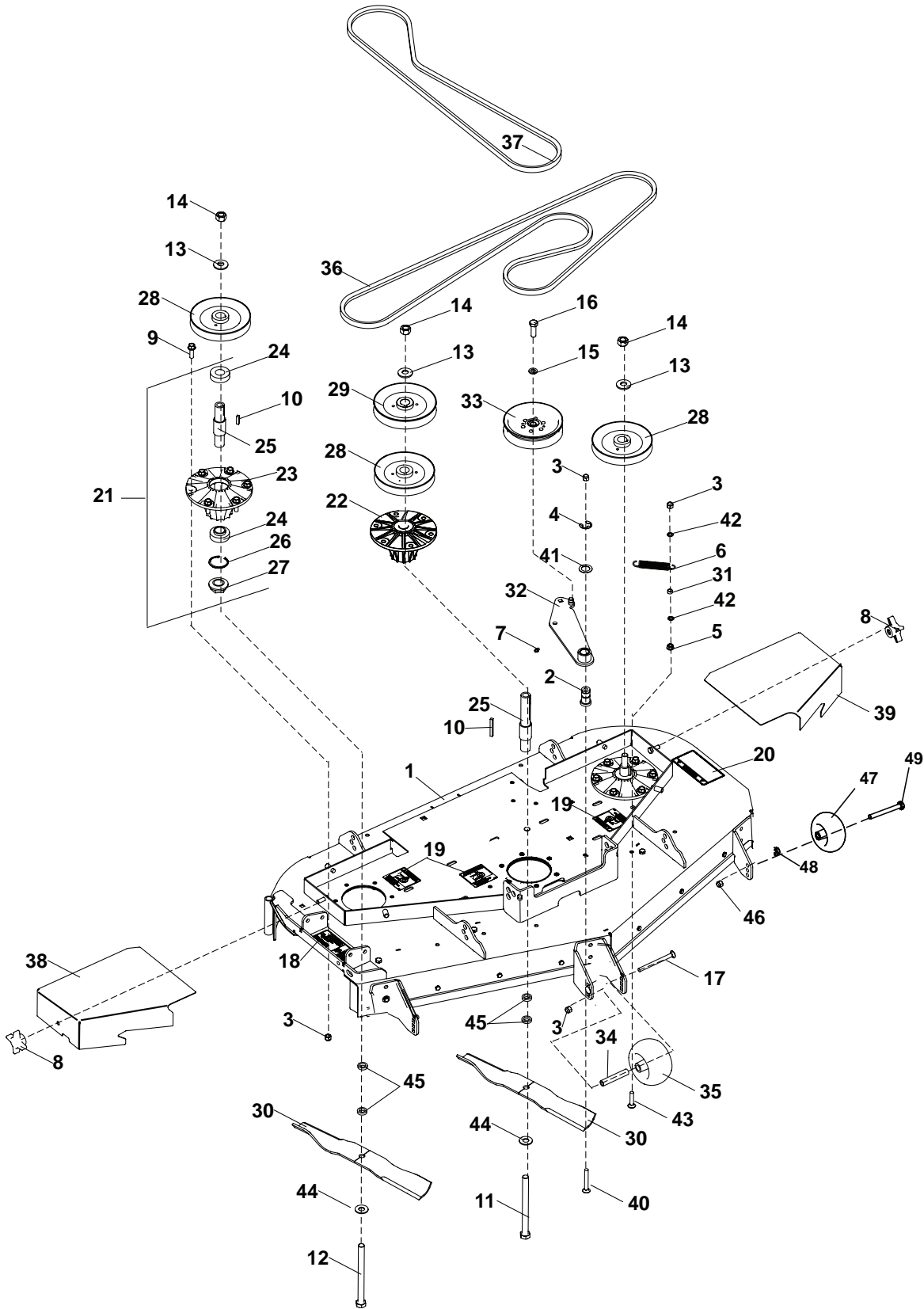



## FIGURE 15

ITEM	PART NO.	DESCRIPTION	QTY	ITEM	PART NO.	DESCRIPTION	QTY
1	4170054	S-DECK 48" W/ LABELS	1	23	4164948	HOUSING-SPINDLE 6 HOLE	3
2	4116661	PIN-PIVOT	1	24	4167554-01	BEARING-SPINDLE SEALED	6
3	64229-03	NUT-NYLON LOCK 3/8-16	23	25	33179-02	SPINDLE-SHORT	2
4	64221-04	E-RING .875	1		33179-01	SPINDLE-LONG	1
5	64141-4	NUT-WLF 3/8-16	1	26	64144-38	SNAP RING	3
6	2188131	SPRING, EXT	1	27	38315	NUT-SPINDLE	3
7	85010N	ZERK 1/4-28 STR SF THRD	1	28	2308140	PULLEY-ENGINE	3
8	38524	KNOB-4 PRONG 3/8-16	2	29	4169408	PULLEY-SPINDLE 52, UPPER	1
9	64262-012	BLT-FLG HD 3/8-16 X 1-1/4	18	30	112111-01	BLADE 16.25 OFFST HLFT	3
10	64164-12	KEY-1/4X1 SQ (USED IN SHORT SPINDLE)	2	31	521679	BUSHING	1
	64164-13	KEY 1/4 X 2 SQ (USED IN LONG SPINDLE)	1	32	4170069.7	WLDMT-IDLER, DECK	1
11	64123-157	BLT-HEX 5/8-18X9	1	33	128169	PULLEY IDLER 5.50	1
12	64123-265	BLT-HEX 5/8-18X7.5	2	34	2720685	SPACER-ROLLER	1
13	64209-03	SPRING WASHER.67 ID	3	35	2721512	ROLLER-5X2.75 CENTERED	1
14	64025-16	NUT-HEX 5/8-18	3	36	128110	BELT-CUTTER DECK	1
15	64006-05	LOCKWSHR-1/2 HELICAL	1	37	4169870	BELT-HB,75.625IN	1
16	64123-05	BLT-HEX 1/2-20 X 1-1/2	1	38	4169586.2	COVER-BELT, DECK 48 RH	1
17	64018-30	BLT-CRG 3/8-16 X 4-1/2	3	39	4169585.2	COVER-BELT, DECK 48 LH	1
18	4164269	LABEL-WARNING THROWN	1	40	64018-47	BLT-CRG 3/8-16X2-3/4	1
19	2000577	DECAL, "ROTATING PARTS"	3	41	64163-65	WSHR-.890X1.375X18GA	1
20	2000572	LABEL-WARNING BLADES	1	42	64163-04	WSHR 25/64X5/8X16GA	2
21	4171184	S-ASSY SPINDLE 6 SHORT (INCLUDES 10, 23-27)	2	43	64018-39	BLT-CRG 3/8-16X1-3/4 FLTH	1
				44	64163-16	WSHR 41/64X1-3/8X12 GA	3
22	4171185	S-ASSY SPINDLE 6 LONG (INCLUDES 10, 23-27)	1	45	64163-12	WSHR .635/.640X1.0X.25	6
				46	64268-05	NUT-FL NYLON LOCK 1/2-13	2
				47	4163332	ROLLER, ANTI-SCALP	2
				48	64141-13	NUT WLF 1/2-13	2
				49	64123-31	BLT-HEX 1/2-13X3	2

# MOUNTING-52" DECK

# Hydro Midsize

## FIGURE 16

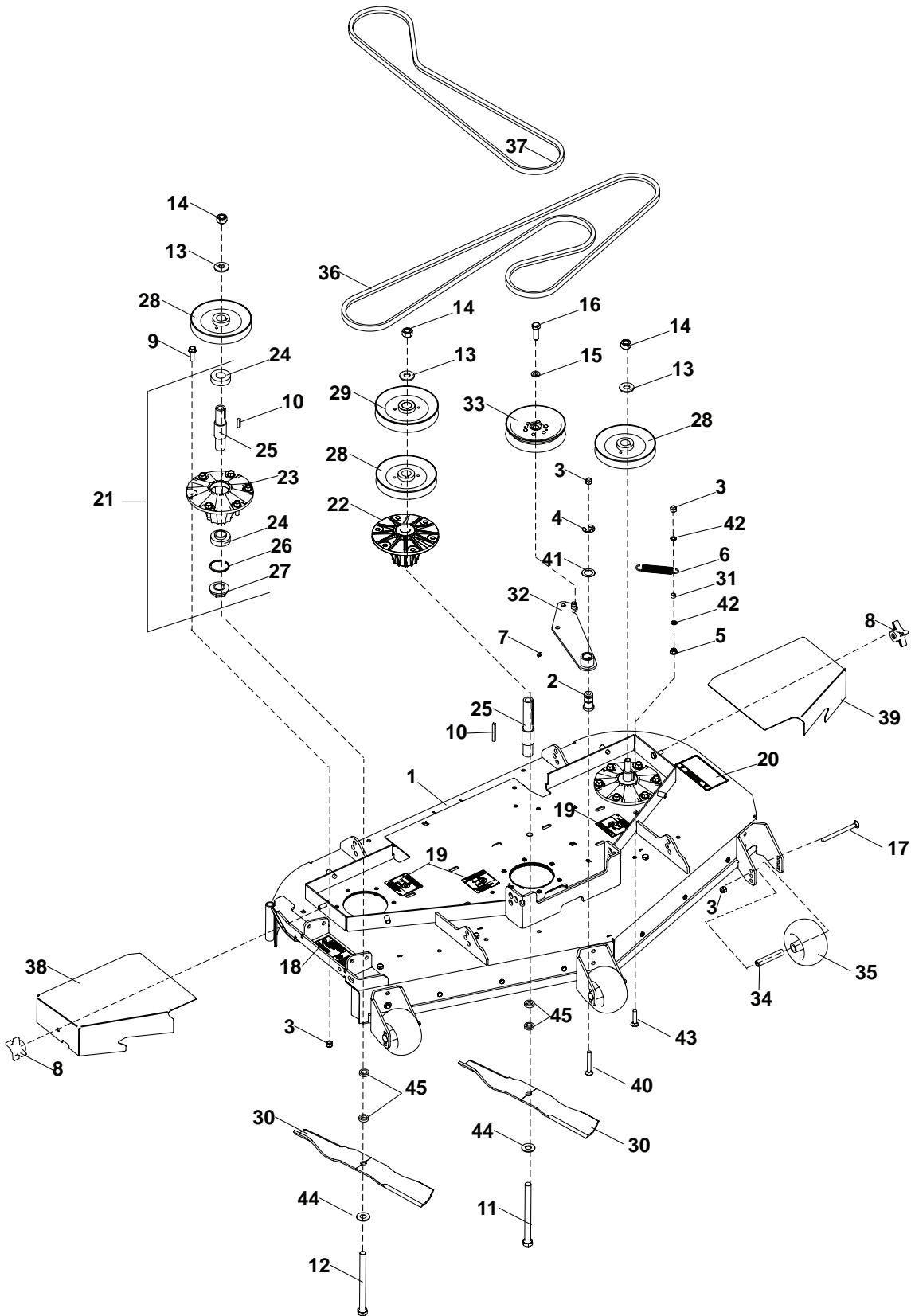

## FIGURE 16

ITEM	PART NO.	DESCRIPTION	QTY	ITEM	PART NO.	DESCRIPTION	QTY
1	4170055	S-DECK 52" W/ LABELS	1	23	4164948	HOUSING-SPINDLE 6 HOLE	3
2	4116661	PIN-PIVOT	1	24	4167554-01	BEARING-SPINDLE SEALED	6
3	64229-03	NUT-NYLON LOCK 3/8-16	23	25	33179-02	SPINDLE-SHORT	2
4	64221-04	E-RING .875	1		33179-01	SPINDLE-LONG	1
5	64141-4	NUT-WLF 3/8-16	1				
6	2188131	SPRING, EXT	1	26	64144-38	SNAP RING	3
7	85010N	ZERK 1/4-28 STR SF THRD	1	27	38315	NUT-SPINDLE	3
8	38524	KNOB-4 PRONG 3/8-16	2	28	2308140	PULLEY-ENGINE	3
9	64262-012	BLT-FLG HD 3/8-16 X 1-1/4	18	29	4169408	PULLEY-SPINDLE 52, UPPER	1
10	64164-12	KEY-1/4X1 SQ (USED IN SHORT SPINDLE)	2	30	112111-02	BLADE 18.00 OFFST HLFT	3
	64164-13	KEY 1/4 X 2 SQ (USED IN LONG SPINDLE)	1	31	521679	BUSHING	1
				32	4170069.7	WLDMT-IDLER, DECK	1
11	64123-157	BLT-HEX 5/8-18X9	1	33	128169	PULLEY IDLER 5.50	1
12	64123-265	BLT-HEX 5/8-18X7.5	2	34	2720685	SPACER-ROLLER	3
13	64209-03	SPRING WASHER.67 ID	3	35	2721512	ROLLER-5X2.75 CENTERED	3
14	64025-16	NUT-HEX 5/8-18	3	36	2188176	BELT-DECK 52	1
15	64006-05	LOCKWSHR-1/2 HELICAL	1	37	4169870	BELT-HB, 75.625IN	1
16	64123-05	BLT-HEX 1/2-20 X 1-1/2	1	38	4169428.2	COVER-BELT, DECK 52 RH	1
17	64018-30	BLT-CRG 3/8-16 X 4-1/2	3	39	4169429.2	COVER-BELT, DECK 52 LH	1
18	4164269	LABEL-WARNING THROWN	1	40	64018-47	BLT-CRG 3/8-16X2-3/4	1
19	2000577	DECAL, "ROTATING PARTS"	3	41	64163-65	WSHR-.890X1.375X18GA	1
20	2000572	LABEL-WARNING BLADES	1	42	64163-04	WSHR 25/64X5/8X16GA	2
21	4171184	S-ASSY SPINDLE 6 SHORT (INCLUDES 10, 23-27)	2	43	64018-39	BLT-CRG 3/8-16X1-3/4	1
				44	64163-16	WSHR 41/64X1-3/8X12 GA	3
22	4171185	S-ASSY SPINDLE 6 LONG (INCLUDES 10, 23-27)	1	45	64163-12	WSHR .635/.640X1.0X.25	6

# MOUNTING-61" DECK

# Hydro Midsize

## FIGURE 17

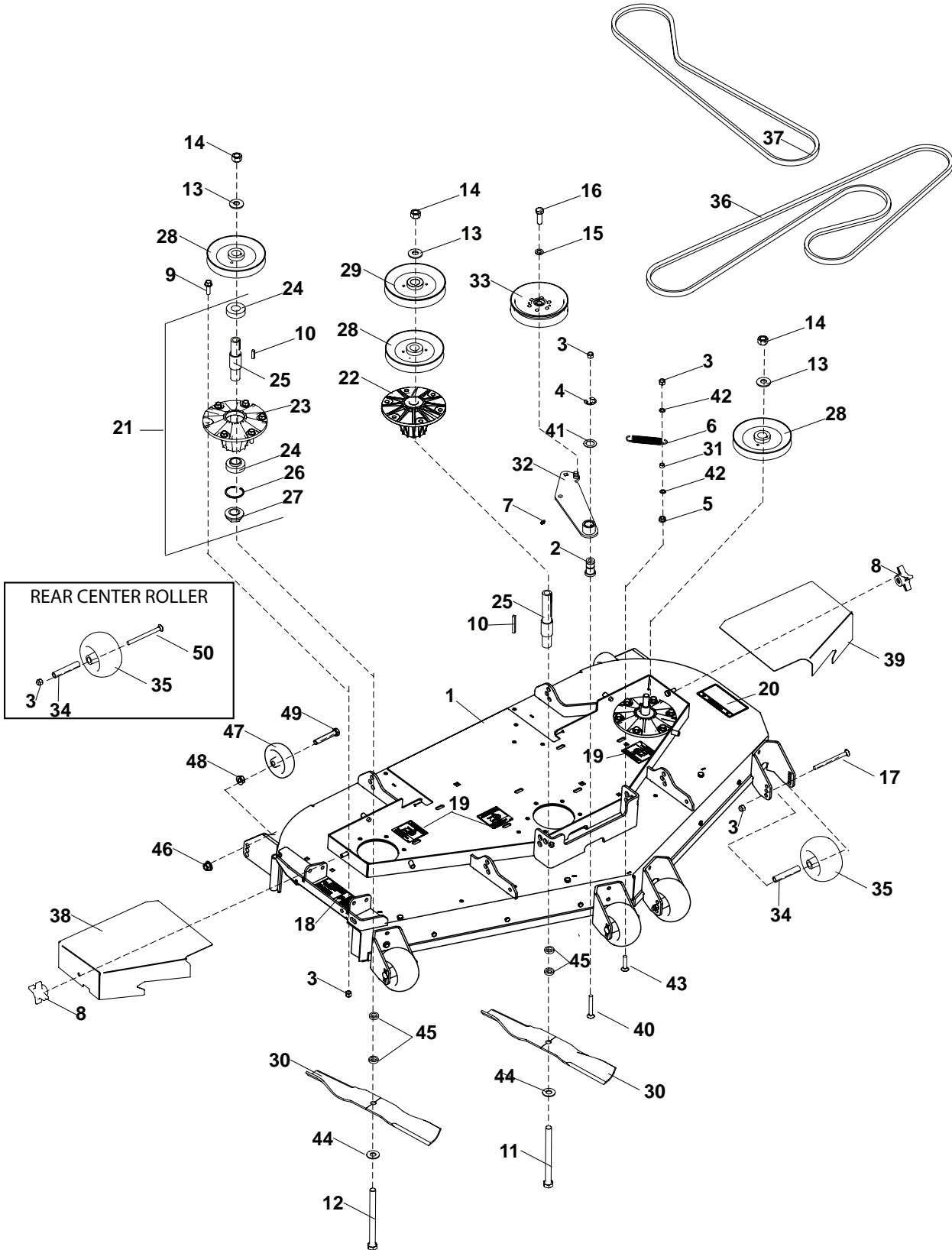

## FIGURE 17

ITEM	PART NO.	DESCRIPTION	QTY	ITEM	PART NO.	DESCRIPTION	QTY
1	4170056	S-DECK 61" W/ LABELS	1	23	4164948	HOUSING-SPINDLE 6 HOLE	3
2	4116661	PIN-PIVOT	1	24	4167554-01	BEARING-SPINDLE SEALED	6
3	64229-03	NUT-NYLON LOCK 3/8-16	25	25	33179-02	SPINDLE-SHORT	2
4	64221-04	E-RING .875	1		33179-01	SPINDLE-LONG	1
5	64141-4	NUT-WLF 3/8-16	1	26	64144-38	SNAP RING	3
6	2188131	SPRING, EXT	1	27	38315	NUT-SPINDLE	3
7	85010N	ZERK 1/4-28 STR SF THRD	1	28	2308140	PULLEY-ENGINE	3
8	38524	KNOB-4 PRONG 3/8-16	2	29	4169530	PULLEY-SPINDLE 61,UPPER	1
9	64262-012	BLT-FLG HD 3/8-16 X 1-1/4	18	30	112111-03	BLADE 21.00 OFFST HLFT	3
10	64164-12	KEY-1/4X1 SQ (USED IN SHORT SPINDLE)	2	31	521679	BUSHING	1
	64164-13	KEY 1/4 X 2 SQ (USED IN LONG SPINDLE)	1	32	4170069.7	WLDMT-IDLER, DECK	1
				33	128169	PULLEY IDLER 5.50	1
11	64123-157	BLT-HEX 5/8-18X9	1	34	2720685	SPACER-ROLLER	5
12	64123-265	BLT-HEX 5/8-18X7.5	2	35	2721512	ROLLER-5X2.75 CENTERED	5
13	64209-03	SPRING WASHER.67 ID	3	36	128003	BELT-CUTTER DECK	1
14	64025-16	NUT-HEX 5/8-18	3	37	4169885	BELT-HB,83.34IN	1
15	64006-05	LOCKWSHR-1/2 HELICAL	1	38	4169628.2	COVER-BELT, DECK 61 RH	1
16	64123-05	BLT-HEX 1/2-20 X 1-1/2	1	39	4169627.2	COVER-BELT, DECK 61 LH	1
17	64018-30	BLT-CRG 3/8-16 X 4-1/2	4	40	64018-47	BLT-CRG 3/8-16X2-3/4	1
18	4164269	LABEL-WARNING THROWN	1	41	64163-65	WSHR-.890X1.375X18GA	1
19	2000577	DECAL, "ROTATING PARTS"	3	42	64163-04	WSHR 25/64X5/8X16GA	2
20	2000572	LABEL-WARNING BLADES	1	43	64018-39	BLT-CRG 3/8-16X1-3/4	1
21	4171184	S-ASSY SPINDLE 6 SHORT (INCLUDES 10, 23-27)	2	44	64163-16	WSHR 41/64X1-3/8X12 GA	3
				45	64163-12	WSHR .635/.640X1.0X.25	6
22	4171185	S-ASSY SPINDLE 6 LONG (INCLUDES 10, 23-27)	1	46	64268-05	NUT-FL NYLON LOCK 1/2-13	2
				47	4163332	ROLLER, ANTI-SCALP	2
				48	64141-13	NUT WLF 1/2-13	2
				49	64123-31	BLT-HEX 1/2-13X3	2
				50	64123-173	BLT-HEX 3/8-16X4-1/2	1

# BAFFLES, CHUTE & LEADING EDGES

# Hydro Midsize

FIGURE 18

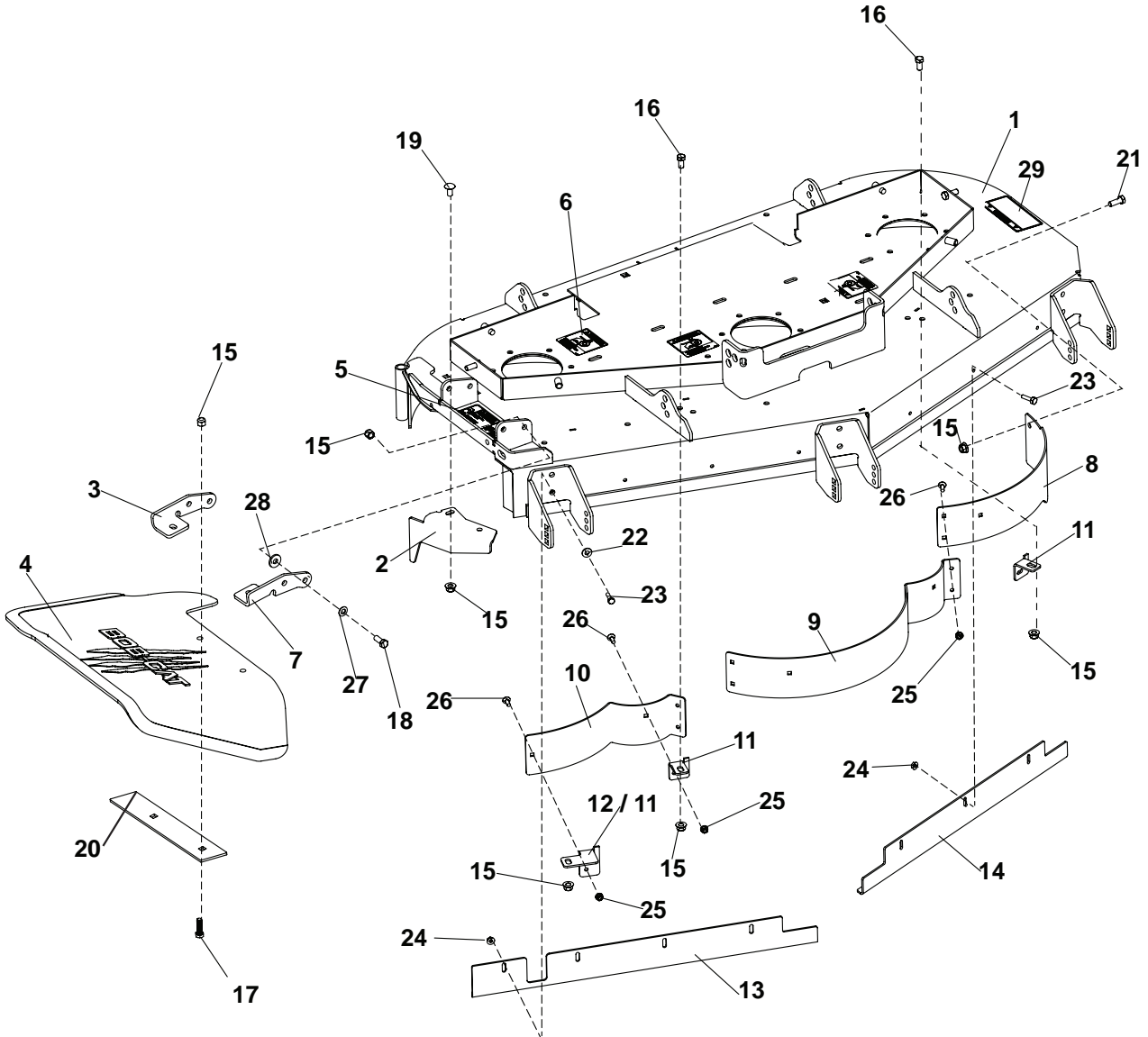

### FIGURE 18

ITEM	PART NO.	DESCRIPTION	QTY	ITEM	PART NO.	DESCRIPTION	QTY
1	4170054	S-48 DECK W/LABELS	1	15	64268-03	NUT-FL NYLON LOCK 3/8-16	8
	4170055	S-52 DECK W/LABELS		16	64123-15	BLT-HEX 3/8-16X3/4	3
	4170056	S-61 DECK W/LABELS		17	64018-7	BLT-CRG 3/8-16X1-1/4	2
2	4165976.7	BAFFLE-DISCHARGE, 48"	1	18	64123-16	BLT-HEX 3/8-16X1-1/4	2
	4168085.2	BAFFLE-DISCHARGE, 52"		19	64018-23	BLT-CRG 3/8-16X3/4 SHRTNK	2
	4171432.2	BAFFLE-DISCHARGE, 61"		20	4169851.7	PLATE-SUPPORT	1
3	4169849.7	BRACKET-CHUTE, REAR	1	21	64123-50	BLT-HEX 3/8-16X1	1
	4168131	CHUTE-DSCHRG, PLASTIC		22	64163-55	WSHR .328X.75X14 GA	1
	4164269	LABEL-WARNING THROWN		23	64123-114	BLT-HEX 1/4-20X1	7
5	2000577	LABEL WARNING	3	24	64141-2	NUT-WLF 1/4-20	7
7	4169850.7	BRACKET-CHUTE, FRONT	1	25	64268-01	NUT-FL 1/4-20 NYLON	7
8	4165971.7	BAFFLE-FRONT LH, 48"	1	26	64018-2	BLT-CRG 1/4-20X3/4	7
	4165965.7	BAFFLE-FRONT LH, 52"		27	4169895	WASHER-FRICTION,UHMW	2
	4165968.7	BAFFLE-FRONT LH, 61"		28	4169871	WASHER-BELLVILLE,.382 ID	2
9	4165972.7	BAFFLE-FRONT CENTER, 48"	1	29	2000572	LABEL-WARNING BLADES	1
	4165966.7	BAFFLE-FRONT CENTER, 52"					
	4168642.7	BAFFLE-FRONT CENTER, 61"					
10	4168527.7	BAFFLE-RIGHT FRONT, 48"	1				
	4168516.7	BAFFLE-RIGHT FRONT, 52"					
	4171792.7	BAFFLE-RIGHT FRONT, 61"					
11	4168514.2	BRKT-BAFFLE MNTG, 48"	3				
	4168514.2	BRKT-BAFFLE MNTG, 52"	2				
	4168523.2	BRKT-BAFFLE MNTG, 61"	2				
12	4168515.2	BRKT-BAFFLE MNTG, RH 52"	1				
	4168487.2	BRKT-BAFFLE MNTG, RH 61"	1				
13	4166929.2	EDGE-LEADING RH 48"	1				
	4166478.2	EDGE-LEADING RH 52"					
	4166480.2	EDGE-LEADING RH 61"					
14	4166930.2	EDGE-LEADING LH 48"	1				
	4166479.2	EDGE-LEADING LH 52"					
	4166481.2	EDGE-LEADING LH 61"					

**SCHILLER GROUNDS CARE, INC.**  
**ONE BOB-CAT LANE**  
**P.O. BOX 469**  
**JOHNSON CREEK, WI 53038**  
**920-699-2000**  
**[www.schillergc.com](http://www.schillergc.com)**



©Schiller Grounds Care, Inc. 2010