



942630

**BOB-CAT XRZ PRO RS FX651V KAW W/48 SIDE DISCHARGE
S/N 0390 thru Present**

942631

**BOB-CAT XRZ PRO RS FX691V KAW W/52 SIDE DISCHARGE
S/N 1173 thru Present**

942632

**BOB-CAT XRZ PRO RS FX730V KAW W/61 SIDE DISCHARGE
S/N 0820 thru Present**

942633

**BOB-CAT XRZ PRO RS FX850V KAW W/52 SIDE DISCHARGE
S/N 0000 thru Present**

942634

**BOB-CAT XRZ PRO RS FX850V KAW W/61 SIDE DISCHARGE
S/N 0000 thru Present**

MAN 4175357
Rev. B 02-2019



PARTS / OPERATOR'S MANUAL

CALIFORNIA PROPOSITION 65



WARNING: Cancer and Reproductive Harm - www.P65Warnings.ca.gov.



ADVERTENCIA: Cáncer y Daño Reproductivo - www.65Warnings.ca.gov.

▲ WARNING

The engine exhaust from this product contains chemicals known to the State of California to cause cancer, birth defects or other reproductive harm.

▲ ADVERTENCIA

El estado de California hace saber que los gases de escape de este producto contienen productos químicos que producen cáncer, defectos de nacimiento y otros daños en el proceso de reproducción humana.

IMPORTANT!

It is a violation of California Public Resource Code Section 4442 or 4443 to use or operate the engine on any forest-covered, brush-covered or grass-covered land unless the engine is equipped with a spark arrestor, as defined in Section 4442, maintained in effective working order or the engine is constructed, equipped, and maintained for the prevention of fire.

To acquire a spark arrestor for your unit, see your Engine Service Dealer.

Please refer to the engine manufacturer's information included with the machine.

Labeled power ratings are supplied by the engine manufacturer in accordance with SAE testing and gross/net power rating standards (J1940, J1995, J1349).

IMPORTANT MESSAGE

Thank you for purchasing this Schiller Grounds Care, Inc. product. You have purchased a world class mowing product, one of the best designed and built anywhere.

This machine comes with an Operation and Safety Manual. The useful life and good service you receive from this machine depends to a large extent on how well you read and understand this manual. Treat your machine properly, lubricate and adjust it as instructed, and it will give you many years of reliable service.

Your safe use of this Schiller Grounds Care, Inc. product is one of our prime design objectives. Many safety features are built in, but we also rely on your good sense and care to achieve accident-free operation. For best protection, study the manual thoroughly. Learn the proper operation of all controls. Observe all safety precautions. Follow all instructions and warnings. Do not remove or defeat any safety features. Make sure those who operate this machine are as well informed and careful in its use as you are.

See a Schiller Grounds Care, Inc. dealer for any service or parts needed. Schiller Grounds Care, Inc. service ensures that you continue to receive the best results possible from Schiller Grounds Care, Inc. products. You can trust Schiller Grounds Care, Inc. replacement parts because they are manufactured with the same high precision and quality as the original parts.

Schiller Grounds Care, Inc. designs and builds its equipment to serve many years in a safe and productive manner. For longest life, use this machine only as directed in the manuals, keep it in good repair and follow safety warnings and instructions. You'll always be glad you did.

Schiller Grounds Care, Inc.
One Bob Cat Lane
Johnson Creek, WI 53038-0469

TABLE OF CONTENTS	PAGE
SAFETY.....	2-9
SET UP INSTRUCTIONS.....	10, 1
LABELS.....	12-14
CONTROLS.....	15-18
PRE-OPERATION CHECK LIST.....	19
OPERATION.....	20-22
MAINTENANCE CHART.....	23
MAINTENANCE RECORD.....	24
MAINTENANCE.....	25-31
ADJUSTMENTS.....	32-34
BELT REPLACEMENT.....	35, 36
PARTS SECTION.....	37
FRAME-ENGINE/CLUTCH ASSY.....	FIGURE 1 38, 37
TRANSAXLE ASSY.....	FIGURE 2 40, 41
FUEL TANK & CONTROL PANEL.....	FIGURE 3 42, 43
BUMPER, FUEL VALVE & COVER PLATE.....	FIGURE 4 44, 45
DECK LIFT ASSEMBLY.....	FIGURE 5 46, 47
CASTER ASSEMBLY.....	FIGURE 6 48, 49
KICKPLATE/SEAT ASSEMBLY.....	FIGURE 7 50, 51
STEERING.....	FIGURE 8 52, 53
PARKING BRAKE.....	FIGURE 9 54, 55
WIRE HARNESS 942630, 942631, 942632.....	FIGURE 10 56, 57
48" SIDE DISCHARGE.....	FIGURE 11 58, 59
52" SIDE DISCHARGE.....	FIGURE 12 60, 61
61" SIDE DISCHARGE.....	FIGURE 13 62, 63
CHUTE, BAFFLES, EDGES & DECK LIFTS.....	FIGURE 14 64, 65
DECALS-POWERUNIT.....	FIGURE 15 66, 67
ROPS.....	FIGURE 16 68, 69

NOTICE !!!

Unauthorized modifications may present **extreme** safety hazards to operators and bystanders and could also result in product damage.

Schiller Grounds Care, Inc. strongly warns against, rejects and disclaims any modifications, add-on accessories or product alterations that are not designed, developed, tested and approved by Schiller Grounds Care, Inc. Engineering Department. Any Schiller Grounds Care, Inc. product that is altered, modified or changed in any manner not specifically authorized after original manufacture—including the addition of “aftermarket” accessories or component parts not specifically approved by Schiller Grounds Care, Inc. will result in the Schiller Grounds Care, Inc. Warranty being voided.

Any and all liability for personal injury and/or property damage caused by any unauthorized modifications, add-on accessories or products not approved by Schiller Grounds Care, Inc. will be considered the responsibility of the individual(s) or company designing and/or making such changes. Schiller Grounds Care, Inc. will vigorously pursue full indemnification and costs from any party responsible for such unauthorized post-manufacture modifications and/or accessories should personal injury and/or property damage result.



This symbol means:
ATTENTION!
BECOME ALERT!

Your safety and the safety of others is involved.

Signal word definitions:

The signal words below are used to identify levels of hazard seriousness. These words appear in this manual and on the safety labels attached to Schiller Grounds Care, Inc. machines. For your safety and the safety of others, read and follow the information given with these signal words and/or the symbol shown above.



DANGER indicates an imminently hazardous situation which, if not avoided, **WILL** result in death or serious injury.



WARNING indicates a potentially hazardous situation which, if not avoided, **COULD** result in death or serious injury.



CAUTION indicates a potentially hazardous situation which, if not avoided, **MAY** result in minor or moderate injury. It may also be used to alert against unsafe practices or property damage.



CAUTION used without the safety alert symbol indicates a potentially hazardous situation which, if not avoided, **MAY** result in property damage.



MODEL NUMBER: This number appears on sales literature, technical manuals and price lists.

SERIAL NUMBER: This number appears only on your mower. It contains the model number followed consecutively by the serial number. Use this number when ordering parts or seeking warranty information.

* **Serial Plate located on left side panel near cut-off switch.**

PREPARING FOR SAFE OPERATION

Operator preparation and training

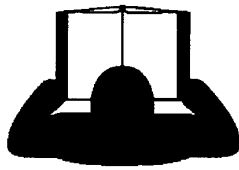

- **Read, understand, and follow instructions and warnings in the manual and on the machine, engine, and attachments. If you don't understand something or it is unclear; contact your dealer representative for clarification.**
- Become familiar with the safe operation of the equipment, operator controls and safety signs. Be prepared to stop the engine and attachments quickly in an emergency. Do not operate or allow another person to operate this machine if there are any questions about safety.
- Only allow operators who are responsible, trained, familiar with the instructions, and physically capable to operate or service the machine. The owner is responsible for training the users.
- Wear appropriate clothing, including long trousers and safety goggles or safety glasses with side shields when operating mower. Do not operate barefoot or wearing open sandals. Long hair, loose clothing or jewelry may get tangled in moving parts.
- If an operator or mechanic cannot read English, it is the owner's responsibility to explain this material to them.



CAUTION

This machine produced sound levels in excess of 85dBA at the operator's ear. Extended periods of exposure can cause hearing loss.

- Wear hearing protection.
- Never allow children, unskilled or improperly trained people to operate this equipment. Local regulations can restrict the age of the operator.
- Only adults and mature teenagers should operate a mower. Mature teenagers should have adult supervision. Be sure a teenager:
 1. Has read and understands the operator manual and understands the risks involved.
 2. Is sufficiently mature to use caution; and
 3. Is of sufficient size and weight to operate the controls comfortably and to manage the mower without taking risks.
- Data indicates that those operators age 60 years

and above are involved in a large percentage of riding mower-related injuries. Those operators should evaluate their ability to operate the riding mower safely enough to protect themselves and others from injury.

- Do not carry passengers, especially small children. They may fall off and be seriously injured.
- Keep warning labels and this operator's manual legible and intact. Replacement labels and manuals are available from the factory.
- Do not operate machine while under the influence of drugs or alcohol or any other condition of impairment.
- The owner/user can prevent and is responsible for accidents or injuries occurring to themselves, other people or property.



Site preparation and circumstances

- Evaluate the terrain to determine what accessories and attachments are needed to properly and safely perform the job. Only use accessories and attachments approved by the manufacturer.
- Clear the area to be mowed of objects such as rocks, toys, wire or other debris that may be picked up or thrown by the mower.
- Be sure the area is clear of pets and people, especially young children. Never assume they will remain where you last saw them. Stop the machine if any enter the area.
- Mow only in daylight or in good artificial light.
- Do not mow wet grass as tires may lose traction.

MACHINE PREPARATION

- Do not tamper with or defeat safety devices. Keep guards, shields and interlock safety devices in place and in proper working condition. They are for your protection.
- Keep all fasteners such as nuts, bolts and pins well secured.
- Visually inspect blades, blade bolts and the cut-deck assembly for wear or damage. Replace worn or damaged blades and bolts to preserve balance.
- Verify that machine and attachments, if any, are in good operating condition.
- Grass catcher components are subject to wear, damage and deterioration which could expose moving parts or allow objects to be thrown.

FUELING



- Gasoline can be extremely flammable; gasoline vapors are explosive. Use extra care when handling. A fire or explosion from gasoline can burn you or others and /or cause property damage.
- Fill the fuel tank outdoors on level ground, in an open area, when the engine is cold and wipe up any spilled gasoline.
- If the engine has been running, stop the engine and allow to cool for several minutes.
- Do not smoke, stay away from open flames or other possible ignition sources.
- Refuel outdoors, do not refuel in indoors or in an enclosed trailer.
- Use a funnel.
- Do not overfill. Fill to the bottom of the filler neck. The empty space allows for expansion. Overfilling may result in fuel leakage or damage to the engine or emissions system.
- If fuel is spilled, do not attempt to start the engine until the spill is cleaned up and vapors have cleared.
- Replace caps on fuel containers and tanks securely.
- Do not operate without the entire exhaust system in place and in good working condition.

WARNING



Under certain conditions, static electricity can cause sparks during fueling and start fires or cause explosions. Flowing fuel can generate static electricity. To prevent static electricity sparks:

- Keep fuel containers electrically grounded.
- Do not fill containers in a vehicle or on a truck or trailer bed with a plastic liner. Fill containers on the ground away from the vehicle.
- When practical, remove gas powered equipment from the truck or trailer and refuel it on the ground. If equipment must be refueled on the truck or trailer, refuel from a portable container rather than a dispenser nozzle.
- If a dispenser nozzle must be used, keep the dispenser nozzle in contact with the rim of the fuel tank or container opening until fueling is complete. Do not use a nozzle lock-open device
- Replace caps on fuel cans and tanks securely.
- Fill the fuel tank outdoors.
- Store fuel only in containers specifically designed for fuel.

WARNING



Gasoline is harmful or fatal if swallowed. Long-term exposure to vapors has caused cancer in laboratory animals.

- Avoid prolonged breathing of vapors.
- Keep face away from nozzle and gas tank/container opening.
- Keep away from eyes and skin.
- Do not siphon by mouth.

OPERATING SAFELY  WARNING

Operating engine parts, especially the muffler, become extremely hot. Sever burn can result from contact. Debris such as grass clippings, leaves, brush, etc. can catch fire.

- Allow engine parts, especially the muffler, to cool before touching.
- Remove accumulated debris from engine and muffler area.

 WARNING

Engine exhaust contains carbon monoxide, which is an odorless gas that can kill you.

DO NOT run the engine indoors or in a confined small area (such as an enclosed trailer) where carbon monoxide fumes can collect.

Starting

- Start only according to instructions in this manual or on the machine.
- Lightning can cause severe injury or death. If lightning is seen or thunder is heard in the area, DO NOT operate the machine; seek shelter.
- Be sure all drives are in neutral and parking brake is engaged before starting engine. Use seat belts with the roll bar in the raised and locked position.
- Do not change engine governor settings or overspeed the engine. Operating the engine at excessive speed can increase the hazard of personal injury.

Operation

- Do not put hands or feet near rotating parts or under the machine. Keep clear of the discharge opening at all times.
- This mower was designed for use by one operator. Keep all others away during operation.
- Do not operate when people, especially children, or pets are in the area.
- Stop the machine if anyone enters the area.
- Do not mow in reverse unless absolutely necessary. Always look down and behind before and while backing.
- Slow down and use caution when making turns and crossing roads and sidewalks.
- Stop blades when not moving.
- Stop blades when crossing surfaces other than grass.
- Do not mow with the discharge deflector raised, removed or altered unless there is a grass collection system or mulch kit in place and working properly.
- Do not start the cutting blades until you are ready to start mowing.

- Use care when approaching blind corners, shrubs, trees, or other objects that may obscure vision.
- Do not direct discharge towards others.
- Avoid discharging material against a wall or obstruction. Material may ricochet back toward the operator.
- Obey safety instructions. Failure to do so may cause injury to yourself and/or others.
- Never leave a running machine unattended. Park on level ground, turn off blades, stop engine and remove key before leaving the operator position.

Stopping

- Park the machine on level ground. Stop the engine, remove the key and wait for all parts to stop moving before:
 - Checking cleaning or working on the mower.
 - After striking a foreign object or an abnormal vibration occurs. Inspect and make any necessary repairs before restarting and operating the mower.
 - Before clearing blockages or unclogging.
- Park the machine on level ground. Stop the engine, remove the key and wait for all parts to stop moving.
 - Whenever you leave the mower.
 - Before refueling.
 - Before emptying the grass catcher.
- Be sure all drives are in neutral and parking brake is engaged before starting engine. Use seat belts with the roll bar in the raised and locked position.
- Do not change engine governor settings or overspeed the engine. Operating the engine at excessive speed can increase the hazard of personal injury.

CHILDREN

- Tragic accidents can occur if the operator is not alert to the presence of children. Children are often attracted to the machine and the mowing activity. Never assume that children will remain where you last saw them.
- Keep children out of the operating area and under the watchful care of a responsible adult other than the operator.
- Do not carry children, even with the blade(s) shut off. Children could fall off and be seriously injured or interfere with safe machine operation. Children who have been given rides in the past could suddenly appear in the mowing area for another ride and be run over or backed over by the machine.

MOWING SLOPES**⚠ WARNING**

Operating on wet grass or steep slopes can cause sliding and loss of control. Wheels dropping over edges, ditches, steep banks, or into water can cause roll overs, which may result in serious injury, death or drowning. Slopes are a major factor related to accidents. Operation on slopes requires extra caution.

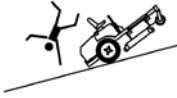

- DO NOT mow slopes when grass is wet.
- DO NOT mow near drop-offs or water.
- Reduce speed and use extreme caution on slopes.
- Do not operate machine under any condition where traction, steering, or stability is in question. Tires could slide even if the wheels are stopped.
- Avoid sudden turns or rapid speed changes.
- Keep ROPS in the raised and locked position and use seat belt.
- Do not mow on slopes if uneasy or uncertain. Ultimate responsibility for safe operation on slopes rests with the operator.
- Do not mow excessively steep slopes.
- With ride-on machines, including articulated steering machines, mow up and down slopes, not across, except for zero turn machines. Zero turn machines should mow across slopes.
- With walk-behind machines, mow across slopes, not up and down.
- With zero turn machines, mow across slopes, not up and down. If the machine will not stay on the slope, it is too steep.
- Mid-mount zero turn (belly mounted deck) machines have much greater traction pointed up slope than down slope. Be aware that traction may be lost going down a slope. Do not operate a mid-mount zero turn on slopes it cannot back up.
- Avoid starting or stopping on a slope. If tires lose traction, disengage the blades and proceed slowly straight down the slope.
- With a zero turn machine, if tires lose traction going down a slope, steering control may be regained by speeding up.
- Keep all movement on the slopes slow and gradual. Do not make sudden changes in speed or direction.
- Do not turn on slopes unless necessary, and then turn slowly and downhill when possible.
- Stay away from slopes if the ground is loose or if caught in the rain during mowing.
- Use extra care with grass catchers or other

attachments. These can change the stability of the machine.

- Remove obstacles such as rocks, tree limbs, etc. from the grass cutting area.
- Avoid driving over obstacles such as ruts, holes, rocks and roots whenever possible. Be alert to dips and rises. Uneven terrain can overturn a mower or cause it to slide. Tall grasses can hide obstacles.
- Do not mow drop-offs, ditches or embankments. The machine could suddenly turn over if a wheel runs over the edge or an edge caves in.
- Follow the manufacturer's recommendations for wheel weights or counterweights to improve stability.
- Be aware that operating on wet grass, across steep slopes or downhill may cause the mower to lose traction. Loss of traction to the drive wheels may result in sliding and loss of braking and steering. Use a walk behind mower and /or hand trimmer near drop-offs, ditches, steep banks or water.

⚠ WARNING

A ROPS is a Roll Over Protective Structure. The ROPS reduces the risk of serious or fatal injury in the unlikely event of a tip over, although the system cannot protect the operator from all possible injuries. It is not designed, made, or intended to provide protection for a machine that is driven off an embankment, retaining wall or similar situation. A ROPS does not replace the need to exercise care when operating on slopes.

IMPORTANT:

- The ROPS is an integral and effective safety device. DO NOT remove or alter the ROPS.
- Keep Roll Bar in the raised position and use the seat belt.
- There is NO roll over protection when the roll bar is lowered. Lower the roll bar only when necessary. DO NOT use the seat belt when the roll bar is in the lowered position. Raise the roll bar as soon as clearance permits.
- Do not cut, drill, modify or repair a ROPS structure in any manner.
- Replace a damaged ROPS.
- Use extreme care when working close to fences, ditches, trees, and on hills.
- Check overhead clearances carefully before driving under any objects.
- DO NOT leave the operator's position while unit is running.
- DO NOT carry passengers.

TRANSPORTING

 WARNING

Loading a machine onto a trailer or truck increases the possibility of tip-over and could cause serious injury or death.

- Use extreme caution when operating a machine on a ramp.
- Have the ROPS in the up position and use the seat belt when loading or unloading the machine unless the ROPS will not clear the top of an enclosed trailer.
- Use only a full-width ramp; do not use individual ramps for each side of machine.
- Avoid sudden acceleration or deceleration while driving the machine on a ramp as this could cause a loss of control or a tip-over situation.
- Shut off fuel when transporting.
- Secure the machine to the truck or trailer.

 WARNING

TOWING EQUIPMENT SAFETY

- Use extra caution when towing.
- Only tow equipment that has a hitch designed for towing.
- Do not attach towed equipment except at the hitch point.
- Follow manufacturer's recommendations for towed equipment, including weight limits and towing on slopes. The weight of the towed equipment may cause loss of traction or loss of control. The mower will respond differently when towing, particularly on slopes. Towed equipment may cause loss of traction and loss of control. For example, the load on a towed trailer may shift during operation adversely affecting control of the mower and towed equipment.
- Read all safety and operating instructions pertaining to the mower and equipment before towing and understand and familiarize yourself with the limitations of the mower and towed equipment prior to towing.
- Always put the ROPS (Roll Over Protection System) in the raised position before towing and always use a seatbelt. Wear the seatbelt whenever the ROPS is raised.
- Always use extra caution when making tight turns. Make wide turns to avoid jack-knifing.

- Know the conditions such as wet grass/ground, slopes, loose gravel, etc., as these factors will affect the traction and handling characteristics of the mower and towed equipment. For example, wet grass reduces traction and control of the mower and towed equipment.
- Travel slowly when towing and allow for extra distance to stop.
- Never allow children or others in or on towed equipment.
- Always park on level ground when towed equipment is attached, and always apply the parking brake when leaving the mower.
- Maximum weight of towed equipment recommended for this mower is 700 lbs. when operating on flat ground. Note: Maximum weight may be reduced depending on specific conditions as noted above. The operator must judge the conditions and determine if towing is appropriate and what maximum weight would be safe to tow.
- Maximum tongue weight should not exceed 25 lbs.

MAINTENANCE SAFETY**In General**

- Keep the machine in good working order.
- Maintain machine according to manufacturer's schedule and instructions for maximum safety and best mowing results.
- Park machine on level ground.
- Never allow untrained personnel to service machine.
- Adjust or repair only after the engine has been stopped and the blades have quit rotating.
- Inspect grass catcher components regularly. If worn, damaged or deteriorated, they may expose moving parts or allow objects to be thrown.
- Replace worn, damaged or faulty parts. For best results, always replace with parts recommended by the manufacturer.
- Disconnect battery or remove spark plug wire(s) before making any repairs. Disconnect the negative terminal first and the positive last. Reconnect positive first and negative last.
- Do not dismantle the machine without releasing or restraining forces which may cause parts to move suddenly.
- Provide adequate support for lifted machine or parts if working beneath.
- Keep hands or feet away from moving parts.
- Clean up oil or fuel spillage thoroughly.
- Replace faulty mufflers.
- To reduce fire hazards, keep the engine, muffler, battery compartment and fuel storage area free of grass, leaves, debris buildup or grease.
- Hydraulic fluid can penetrate skin, use paper to check for leaks. Relieve hydraulic pressure before disconnecting hoses. Make sure connections are tight and hoses are in good condition.

HYDRAULIC SYSTEM**⚠ WARNING**

Hydraulic fluid escaping under pressure can penetrate skin and cause injury. Fluid accidentally injected into the skin must be surgically removed within a few hours by a doctor familiar with this form of injury or gangrene may result.

- If equipped, make sure all hydraulic fluid hoses and lines are in good condition and all hydraulic connections and fittings are tight before applying pressure to hydraulic system.
- Keep body and hands away from pinhole leaks or nozzles that eject high pressure hydraulic fluid.
- Use cardboard or paper, not your hands, to find hydraulic leaks.
- Safely relieve all pressure in the hydraulic system by placing the motion control levers in neutral and shutting off the engine before performing any work on hydraulic system.

⚠ WARNING

Charging or jump starting the battery may produce explosive gases. Battery gases can explode causing serious injury.

- Keep sparks, flames, or cigarettes away from battery.
- Ventilate when charging or using battery in an enclosed space.
- Make sure venting path of battery is always open once battery is filled with acid.
- Always shield eyes and face from battery!

⚠ CAUTION

If the ignition is in the "ON" position there is potential for sparks and engagement of components. Sparks could cause an explosion or moving parts could accidentally engage causing personal injury. Be sure ignition switch is in the "OFF" position before charging the battery.

BLADES



- Mower blades are sharp and can cut. Use extra caution when handling. Remove obstructions with care. Wrap the blade(s) or wear gloves.
- Be aware that rotating one blade on multi blade mowers can cause other blades to rotate.
- Only replace blades. Never straighten or weld them.
- Keep other persons away from blades.

BATTERY



Battery electrolyte contains sulfuric acid which is poisonous and can cause severe burns. Swallowing electrolyte can be fatal. Batteries can produce hydrogen gas which is explosive.

- When working with battery electrolyte, use protective equipment such as, but not limited to, goggles, face shield, rubber gloves and apron.
- Avoid leaning over a battery.
- Do not expose a battery to open flames or sparks.
- Be sure batteries with filler caps are properly filled with fluid.
- Do not allow battery acid to contact eyes or skin. Flush any contacted area with water immediately and get medical help.
- Charge batteries in an open, well ventilated area, away from sparks and flames. Unplug charger before connecting or disconnecting from battery.

Jump starting

1. Be sure the jumper cables are in good condition. Turn off the ignition and all electrical accessories on both machines.
2. Position the machine with a good (charged) battery next to but not touching the machine with the dead battery so jumper cables will reach.
3. When making cable connections:
 - make sure the clamps do not touch anywhere except to intended metal parts.
 - Never connect a positive ("+" or red) terminal to a negative ("- " or black) terminal.
 - Make sure the cables won't get caught in any parts after the engines are started.
4. Connect one end of the first jumper cable to the **positive** terminal on one battery. Connect the other end to the **positive** terminal on the other battery.
5. Connect one end of the other cable to the **negative** terminal of the machine with a good (charged) battery. Make the final connection on the engine of the machine to be started, away from the battery.
6. Start the vehicle with the good battery, then the machine with the discharged battery.
7. Remove the cables in the exact reverse order of installation. When removing each clamp, take care it does not touch any other metal parts while the other end remains attached.

STORAGE SAFETY

- Stop the engine and allow to cool before storing.
- Drain the fuel tank outdoors only.
- Store fuel in an approved container in a cool, dry place.
- Keep the machine and fuel containers in a locked storage place to prevent tampering and to keep children from playing with them.
- When the machine is to be parked, stored or left unattended, lower the cutterdeck unless a positive mechanical lock is used.
- Do not store the machine or fuel container near heating appliances with an open flame such as a water heater or an appliance with a pilot light.
- Keep gasoline storage area free of grass, leaves and excessive grease to reduce fire hazard.
- Clean grass and debris from cutting units, drives, mufflers and engine to help prevent fires.

SET UP INSTRUCTIONS

XRZ PRO RS

TOOLS REQUIRED FOR ASSEMBLY

- Wrecking bar
- Claw hammer
- Sockets: 1/2", 15/16
- Wrenches: 18mm, 1/2", 9/16", 3/4", 15/16"
- Tire pressure gauge

NOTE: All references below to the "right" or "left" are with respect to an operator at the controls.

1. UNCRATE UNIT

- Discard packing materials. Loosen the caster wheel axle bolts and bumper bolts to remove the shipping brackets.
Discard shipping brackets.
- Re-install and tighten bumper bolts.
- Tighten caster wheel axle bolts against caster axle spanner bushings to 80 ft/lbs.

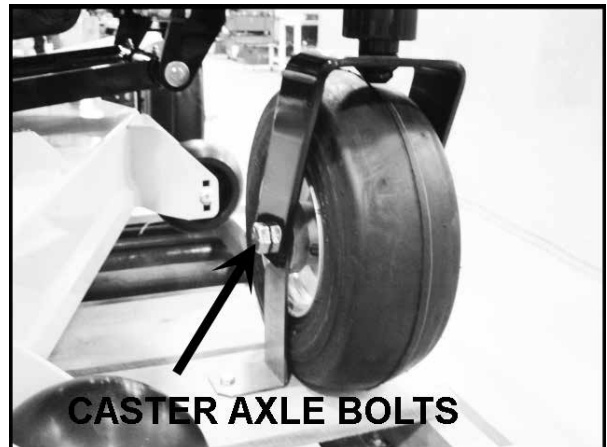
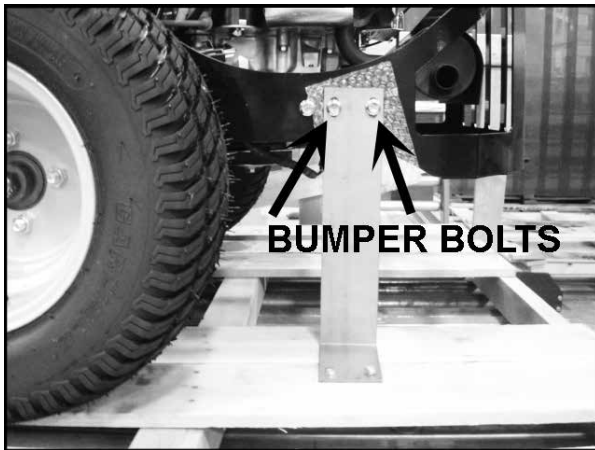

2. TIRE PRESSURE

- Set rear tire pressures to 12 lbs/in² (0.8 kg/cm²). Front tires should be kept inflated to 15 lbs/in² (1.05 kg/cm²). Tires are overinflated for shipping.

3. TRACTION LEVERS

- Tighten bolt **A**.

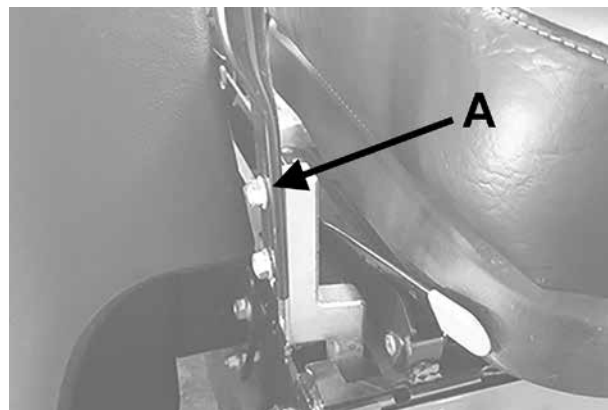

4. FINAL PREPARATIONS

- Check the engine and hydraulic oil levels. Top off with the correct oil if necessary. Use 10W30 motor oil for the engine. Use fresh, clean 20W50 motor oil for the hydraulic system. After running for one hour, let hydraulic system oil cool. When cold check levels.
- Insure Battery cables are connected properly.



WARNING Battery acid is caustic. Fumes are explosive and can cause serious injury or death.

Use insulated tools, wear protective glasses or goggles and protective clothing when working with batteries. Read and obey the battery manufacturer's instructions.

Be certain the ignition switch is OFF and the key has been removed before servicing the battery.

- a) Verify battery polarity before connecting or disconnecting the battery cables.
 - b) When installing the battery, always assemble the RED, positive (+) battery cable first and the ground, BLACK, negative (-) cable last.
 - c) Tighten cables securely to battery terminals and apply a light coat of silicone dielectric grease to terminals and cable ends to prevent corrosion. Keep terminal covers in place.
- Insure all battery cables are routed correctly, to avoid any rotating or moving component to prevent any cable damage.
 - Read Operation and Safety Manual before starting. Operator Manual is located under the seat plate. Tilt seat plate forward to access manual. The seat must be in the most rearward position before tilting.

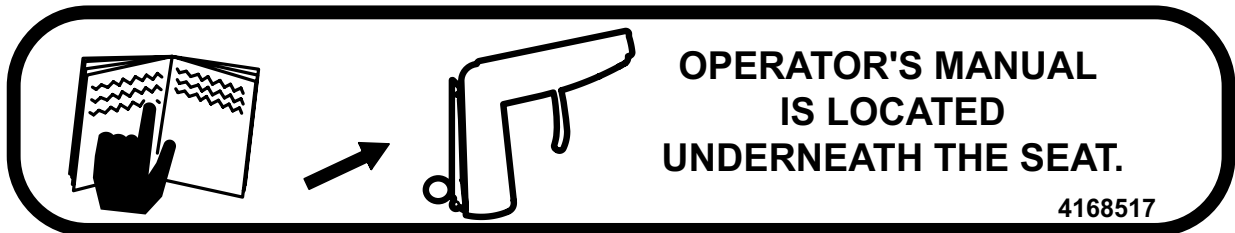

- Deck can be adjusted to allow for the best horsepower, best quality of cut, or best striping. See deck leveling procedure in the Adjustments Section in this manual to set as desired.
- Run engine at full RPM for 5 minutes before engaging blades to allow the engine to be fully lubricated before load is applied.
- Check the hydrostat neutral adjustment. Neutral is set at the factory but may require readjustment. See adjustments section in this manual.
- Do not use the machine without an approved grass collector, the grass discharge chute or mulching plates correctly fitted.

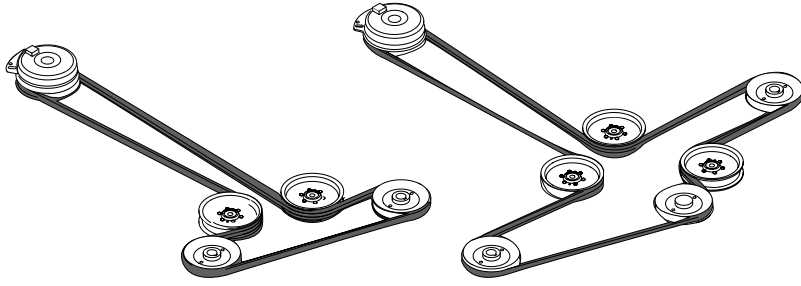

2 BLADES **3 BLADES**

DECK SIZE	BELT P/N	BLADE P/N
42 IN (1067mm)	4171677	112111-03
48 IN (1220mm)	4169566	112111-01
52 IN (1320mm)	4169640	112111-02
61 IN (1550mm)	4163569	112111-03

4171663

**NOTE: Decal is located
under foot plate.**

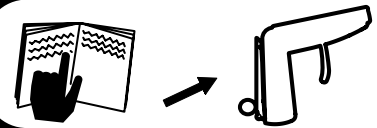

**OPERATOR'S MANUAL
IS LOCATED
UNDERNEATH THE SEAT.**

4168517



⚠ WARNING

**SPARKS OR FLAME CAN START EXPLOSION.
DISCONNECT (-)NEGATIVE TERMINAL FIRST.
RECONNECT (-)NEGATIVE TERMINAL
LAST.**

2000590



⚠ DANGER

ROTATING BLADES

- KEEP HANDS AND FEET AWAY
- STOP ENGINE AND LET BLADES STOP BEFORE REMOVING GRASS COLLECTOR OR UNCLOGGING.



⚠ WARNING

THROWN OBJECTS

- KEEP AREA CLEAR OF PEOPLE AND PETS.
- REMOVE OBJECTS BLADE MAY STRIKE AND THROW.
- STOP BLADES TO CROSS GRAVEL AREAS.
- DO NOT OPERATE WITHOUT CHUTE, MULCHER OR ENTIRE GRASS COLLECTOR IN PLACE.

4164269

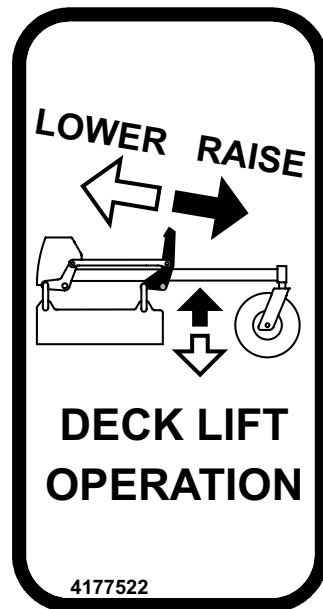
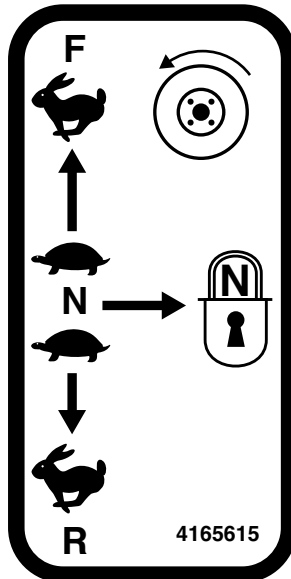
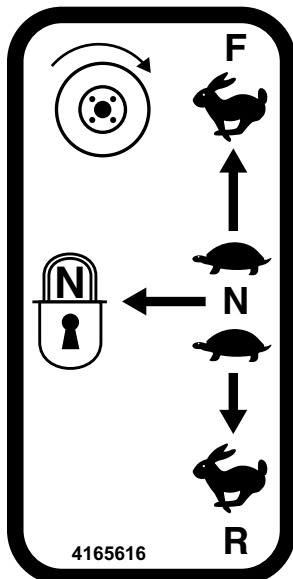
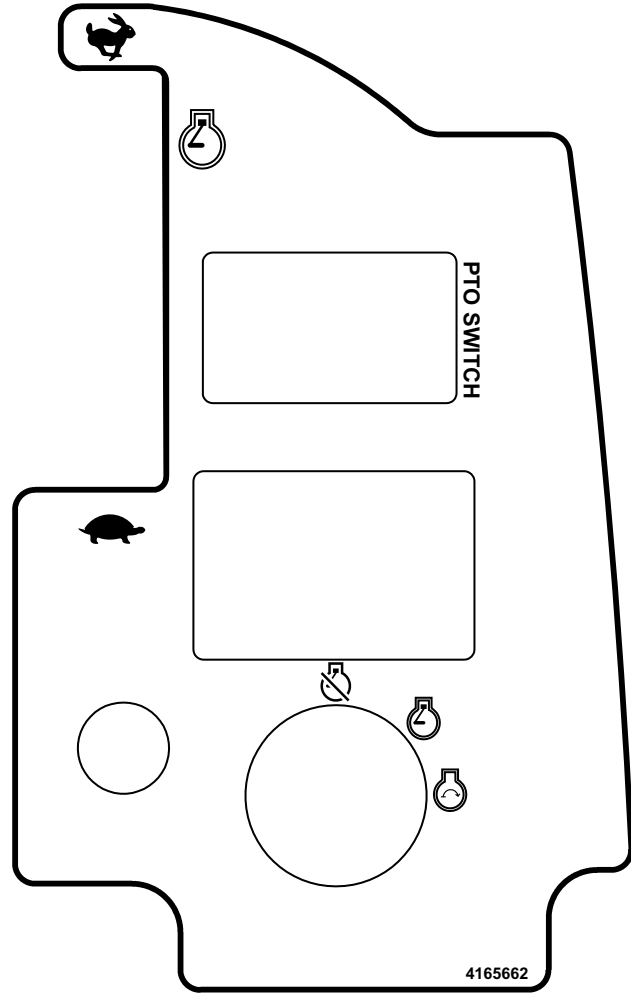
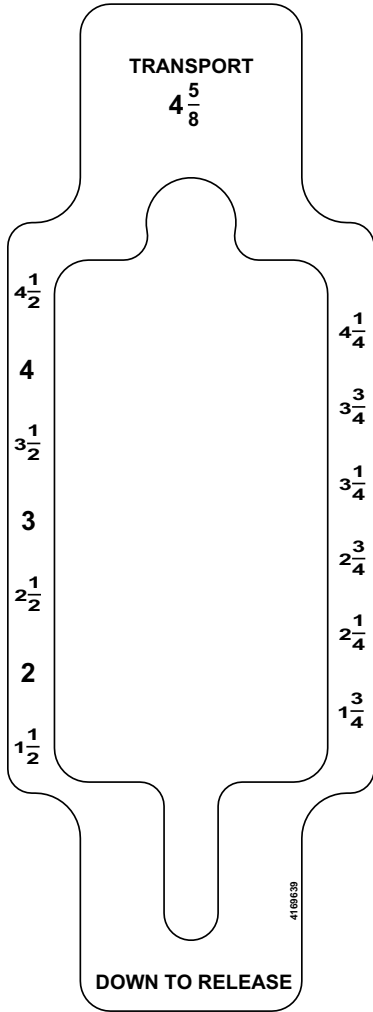

⚠ WARNING

BEFORE STARTING OR SERVICING:



Read and understand the Operator's Manual & labels.

- Be sure machine is in safe operating condition.
- Move traction levers to neutral lock, parking brake to ON.
- Set PTO switch to OFF.

BEFORE LEAVING SEAT:

- Move traction levers to neutral lock, parking brake to ON.
- Set PTO switch to OFF.
- Turn engine keyswitch to OFF.
- Remove key.

⚠ WARNING

AVOID SERIOUS INJURY OR DEATH:

- Read and obey the Operation & Safety Manual.
- Remove objects that could be thrown by the blades.
- Use caution on slopes. Stay off slopes the machine cannot back up.
- Stop blades and drive down slowly if machine slides or stops going on slope.
- Do not mow when children or others are around.
- Do not carry a child or passenger-even with blades off.
- Look down and behind before and while backing.
- Do not operate unless trained.
- Do not operate unless guards, shields and interlocks are in place and working.
- Replace labels and Operation and Safety Manual if lost or damaged.

⚠ WARNING

- Remove debris buildup. Debris under belt cover or near muffler can cause fires.
- Blades continue to rotate for a few seconds after blades are turned off.
- Blades must be at least 1/8" above bottom of housing.
- All blades must be identical. Check blade bolts daily for tightness.
- Inspect for damage after striking a foreign object. Make repairs before restarting operation.
- Find and repair cause of any abnormal vibration.

⚠ ADVERTENCIA

- Leer el manual del operador. No permitir que personas no capacitadas para ello usen la máquina.
- Mantener los protectores en su lugar y sus tornillos debidamente fijados.
- Antes de limpiar, ajustar o reparar este equipo, apagar todos los mandos, aplicar el freno de estacionamiento y apagar el motor.
- Mantener las manos, los pies y la ropa alejados de las piezas en movimiento.
- No conducir como pasajero ni llavar pasajeros en máquinas sin asiento para ello.
- Mantener a las demás personas alejadas durante el funcionamiento de la máquina.
- Si no sabe leer inglés, solicitarle a otra persona que le lea y explique el contenido de las etiquetas y del manual de la máquina.

4165610

⚠ WARNING



**-ROTATING PARTS.
-DO NOT OPERATE WITH
COVER REMOVED.** 2000577

⚠ WARNING



TO CHECK OR ADD FUEL:

- Do it outdoors.
- Stop engine. Allow to cool.
- Do not smoke.
- Clean up spilled fuel.
- Do not overfill.
- Fill to one inch below bottom of filler neck.

2000570

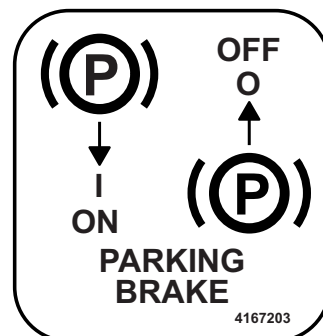

PARKING BRAKE

4167203

KEYSWITCH (K) - The keyswitch has three positions: **OFF**, **RUN**, and **START**. Insert the key and turn it clockwise to move the switch from **OFF** to **RUN**. Turn it further to **START** and hold to engage the starter. Release the key and the switch will return to **RUN** from **START**. Turn the key counterclockwise to **OFF** to stop the engine.

THROTTLE (T) - Move the throttle lever forward to increase engine speed until the maximum governed engine **RPM** is reached. Move the lever rearward to decrease engine speed until the engine reaches its idle speed.

CHOKER (C)
Pull the choke control out to set the choke **ON**. Push it in to set the choke **OFF**.

POWER TAKE OFF (PTO) SWITCH (P) - The operator must be in the seat when engaging the **PTO** or the engine will kill. Pulling the **PTO** switch out engages (turns on) the **PTO** and starts the blades or other attachment. Pushing the **PTO** switch in disengages (turns off) the **PTO** and stops the blades or other attachment.

NOTE: The **PTO** switch does not control attachments powered by a separate engine.

- Disengage the **PTO** whenever you stop or leave the operator's position
- Shut off engine with the key and remove the spark plug wires before making adjustments or unplugging a clogged mower.
- Do not engage the **PTO** until ready to start mowing.

HOUR METER (M) - Records accumulated time the machine is in operation and provides service alerts. Push the release **MODE** button to toggle between functions. Provided service alerts include change engine oil and filter, change hydraulic oil, and service air filter. When the service time is approaching, an alert message will flash temporarily, interrupting whatever mode the meter is in. This will continue until the alert is reset. When the service interval reaches "0" hours, the word "NOW" replaces the hours remaining. To reset the service alert, depress and hold down the mode button for 6 seconds while in the alert to be cleared.

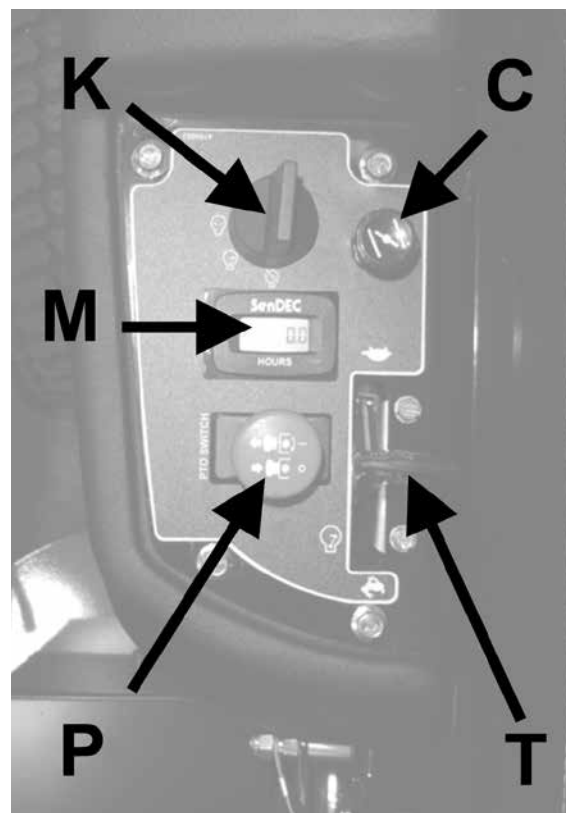

At operator's right side

FOOT PEDAL LIFT LEVER (F) - Used to raise the cutterdeck for curb climbing, blade changing and lifting the deck close to the transport position. To return to preset height of cut, lower foot pedal until latch lever **E** contacts height of cut pin **A**.

TRANSPORT LATCH LEVER (T) - Used to secure the cutterdeck in transport position. To secure the deck, push the foot pedal **F** forward and lift the transport latch lever **T** into the locking position. To release transport latch lever **T**, push the foot pedal **F** slightly forward to disengage latch and press transport latch lever **T** downward. Allow foot pedal **F** to rotate toward machine until latch lever **E** contacts height of cut pin **A**.

HEIGHT OF CUT PIN (A) - Sets height of cut and allows easy return from transport to desired height of cut. Raise the deck to transport using the foot pedal and transfer latch lever **T**. Position pin **A** in the hole corresponding to the desired height of cut. Lower the latch lever until it rests on pin **A**.

12 VOLT POWER OUTLET (X) - A 12 volt power outlet is provided to operate 12 volt personal accessories.

FUEL SELECTOR VALVE (U)

The fuel tank selector valve is located behind the seat. The fuel tank selector valve has three positions:

Off: The tank selector is off when the lever points down. The selector should be off whenever the machine is transported or stands unused for any length of time. Shutting off the fuel supply avoids the possibility of flooding should any dirt get under the carburetor float needle. Leaving the tank selector in either tank position can allow severe flooding, which may ruin the engine by diluting the oil.

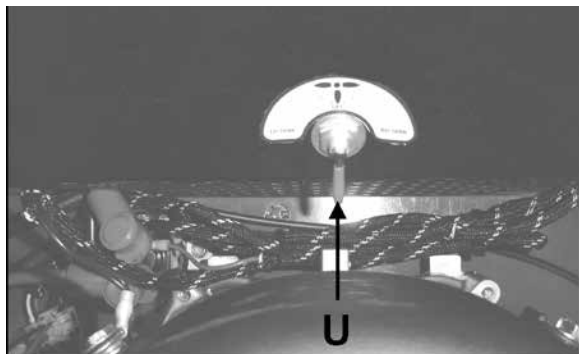
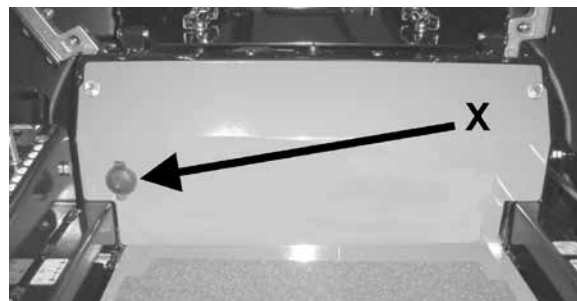
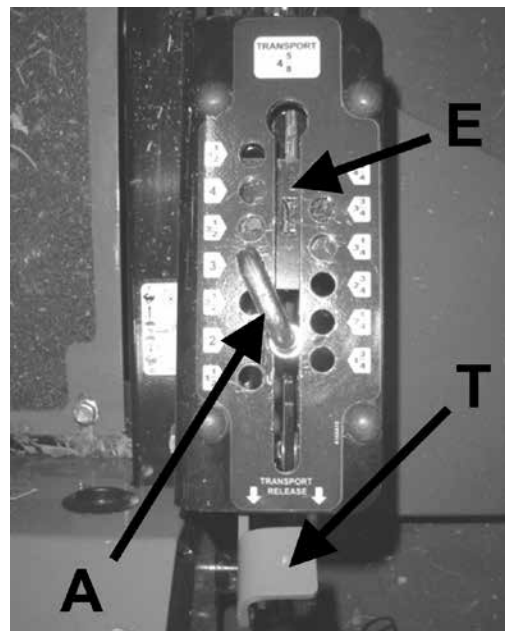
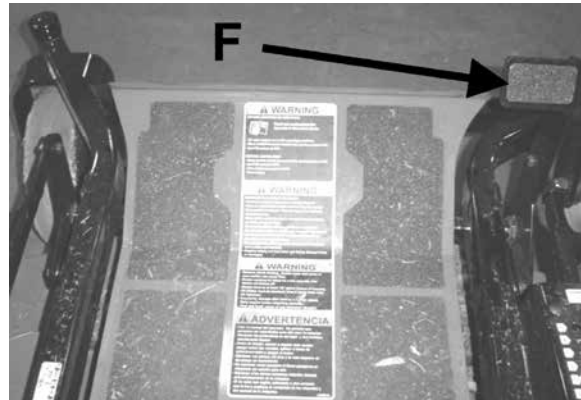

Right Tank: Fuel flows from the right tank when the selector is turned 1/4 turn toward the right.

Left Tank: Fuel flows from the left tank when the selector is turned 1/4 turn toward the left.

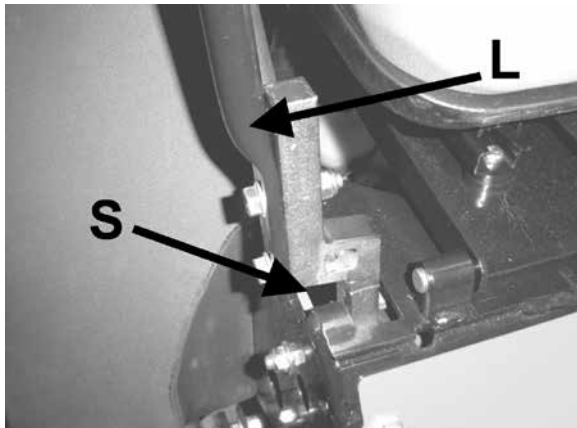

**Lift and traction levers
(operator's right side)**

TRACTION LEVERS (L) - Each of the two traction levers controls the drive wheel located on the same side. They control the forward and reverse movement of the machine, provide steering and also provide dynamic braking.

The operator must be in the seat and the parking brake must be OFF or the traction drive cannot be engaged. To engage traction drive, move the traction levers toward the center of the machine until they are out of neutral lock slot **S**.

Forward movement - To move the machine straight ahead, push both traction levers forward equally from their neutral position. Forward speed increases as the levers are moved farther forward from the neutral position. Maximum forward speed is reached when the levers hit the front of the forward-reverse slot. When traveling forward, pulling the traction levers rearward slows the machine, and the machine stops when the neutral position is reached.

Reverse movement - To move the machine straight back, pull both traction levers back equally from their neutral position. Reverse speed increases as the levers are moved back farther. Maximum reverse speed is reached when the levers hit the rear of the forward-reverse slot. When moving in reverse, pushing the levers forward slows the machine, and the machine stops when the neutral position is reached.

NOTE: Reverse is spring loaded to return to neutral. This spring resistance may be felt when moving the traction levers into reverse. When the levers are released in reverse, spring tension will slowly return them to the neutral position.

STEERING - To steer, move one lever forward and one back.

Turns during forward movement:

- **Right turn** - move the right traction lever back toward neutral to slow the right drive wheel.
- **Left turn** - move the left traction lever back toward neutral to slow the left drive wheel.

Turns during reverse movement:

- **Reverse right turn** - move the right traction lever forward toward neutral to slow the right drive wheel.
- **Reverse left turn** - move the left traction lever forward toward neutral to slow the left drive wheel.

Slow, sweeping turns are made with both traction levers on the same side of neutral and slightly apart. True zero radius turns about the center of the machine are made by having one lever in reverse while the other is in forward. By varying the relative positions of the two levers, the rate of turn is varied to suit the mowing situation.

CAUTION

Slow down or stop before making sharp turns. The machine is capable of turning very rapidly when the levers are moved further apart from each other. Loss of control and/or turf damage may result.

PARKING BRAKE (R) - Pull the parking brake lever up and back to put the parking brake ON. Push it forward and down to put the parking brake OFF.

The parking brake must be ON to start the engine. It must also be ON to keep the engine running if the operator leaves the seat. The parking brake must be OFF to keep the engine running when a traction lever is moved out of neutral lock.

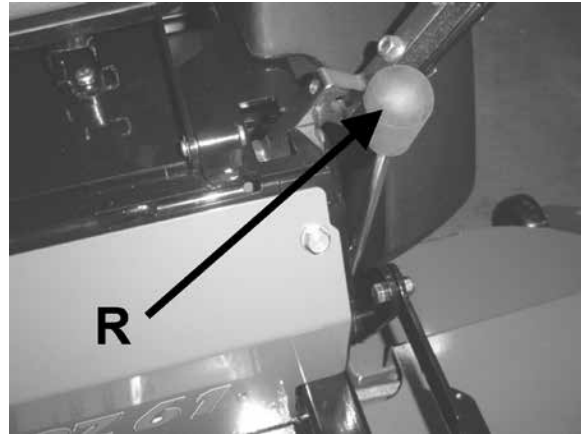

**Parking brake in ON position
(operator's left side)**

PUSHING THE MACHINE

The machine may be pushed with the engine off, the parking brake off, and the bypass valves open.

To open the bypass valves, move the parking brake to the **OFF** position, then lift and pull bypass control rod **C** through the large opening **D**, until the control rod stop is past the opening. Drop rod **C** into the small opening to lock in place. Repeat for the other bypass control rod.

To close the bypass valves, lift bypass control rod **C** allowing the control rod stop to retract through the large opening **D**.

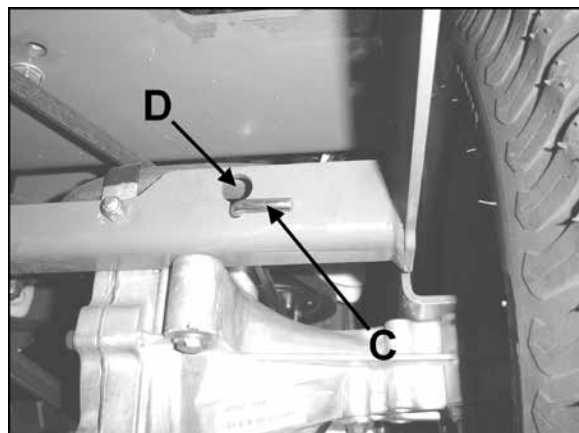
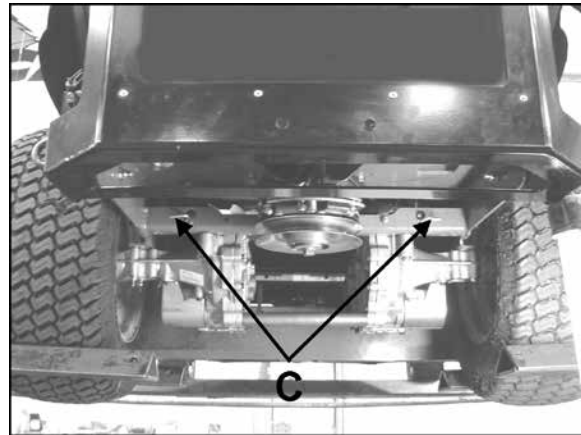

**PRE-OPERATION CHECK LIST
(OPERATOR'S RESPONSIBILITY)**

- | | |
|--|---|
| <ul style="list-style-type: none"> ___ Review and follow all safety rules and safety decal instructions. ___ Check that all safety decals are installed and in good condition. Replace if damaged. ___ Check to make sure all shields and guards are properly installed and in good condition. Be sure that either the discharge shield or complete vacuum attachment is installed. ___ Check that all hardware is properly installed and secured. ___ Check that equipment is properly and securely attached to power unit. ___ Check to be sure engine is free of dirt and debris. Pay particular attention to the cooling fins, governor parts and muffler. Clean air intake screen. Check air cleaner; service if necessary. | <ul style="list-style-type: none"> ___ Never allow riders. ___ Inspect area and remove stones, branches or other hard objects that might be thrown, causing injury or damage. ___ Clean area around oil fill dipstick. Remove dipstick and check to be sure oil is in operating range (between marks on dipstick). Add oil if necessary but Do Not Overfill. Install dipstick assembly firmly until cap bottoms out on tube. Dipstick assembly must always be secured into fill tube when engine is running. ___ Check all lubrication points and grease as instructed in manual. ___ Check hydrostatic fluid level. Check to be sure cooling fins on hydrostat are clean. ___ Perform a functional check of the safety interlock system each time you operate the unit. |
|--|---|

FUELING

- Fill fuel tank with good quality, clean, unleaded regular gasoline. Refer to engine manual.
- Use a funnel to avoid spilling.

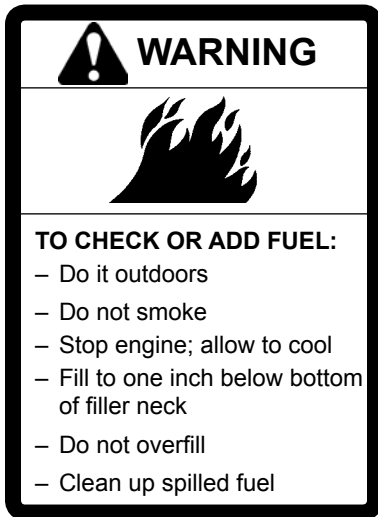

BEFORE STARTING THE ENGINE

- Be familiar with all controls, how each functions and what each operates.
- Check the engine oil level and add if necessary. Using the fuel selector valve, select which tank will supply fuel
- **Choke:** For cold starts, set the throttle lever to the half-open position and pull the choke out to the ON position. For warm starts set the throttle to the half-open position and the choke to the OFF position.

OPERATOR PRESENCE INTERLOCK SYSTEM

To start the engine:

- The PTO switch must be **OFF**.
- Both traction levers must be in the neutral lock position.
- The parking brake must be **ON**.

To operate the machine:

1. The operator must be in the seat or engaging the PTO will kill the engine.
2. The parking brake must be **OFF** and the operator must be in the seat, or moving a traction lever from the neutral lock position will kill the engine.

STARTING THE ENGINE

1. Turn the key to operate the electric starter to start the engine. Release the key when the engine starts.
2. If the engine does not start immediately, do not crank for more than 10 seconds at a time. Allow 60 seconds for the starter motor to cool down between starting attempts to prevent the starter motor from burning out.
3. If the choke is ON when the engine starts, gradually back it off until the engine runs with no choke at all.

OPERATING NOTES

- Practice at slow engine and travel speeds with the PTO off until fully familiar with the controls.
- For normal cutting the throttle should be set at the full open position. By using the traction levers to speed up or slow down the machine during use, maximum control and cutting efficiency can be maintained.
- Using the machine at less than full throttle in heavy conditions will cause the engine to labor and result in excessive wear.

DRIVING

1. With the PTO disengaged, move the parking brake to OFF.
2. Move both traction levers out of neutral lock.
3. Push both traction levers forward evenly to drive forward in a straight line. Pull both traction levers back evenly to drive backward in a straight line.
4. **Steering** - Move one lever forward and one back.

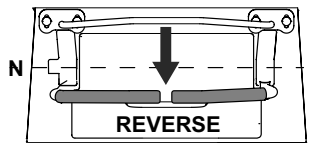
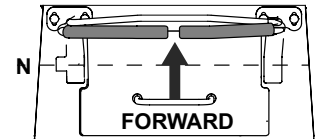

Turns during forward movement:

- **Right turn** - move the right traction lever back toward neutral to slow the right drive wheel.
- **Left turn** - move the left traction lever back toward neutral to slow the left drive wheel.

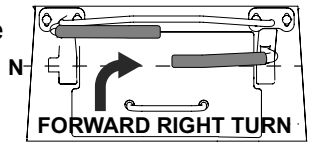

Turns during reverse movement:

- **Reverse right turn** - move the right traction lever forward toward neutral to slow the right drive wheel.
- **Reverse left turn** - move the left traction lever forward toward neutral to slow the left drive wheel.

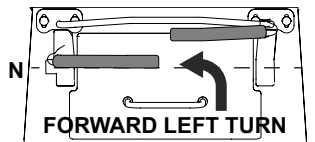

CAUTION

Use caution when making turns. Slow down before making sharp turns to help maintain control and to prevent torn turf from skidding or spinning tires. To help prevent turf damage, keep both drive tires moving whenever a turn is made.

TIP: The best way to make a sharp "zero" turn is to come to a stop, get the machine moving in reverse with both drive wheels and then power the machine around with the outside wheel. This technique keeps the drive tires turning and results in less turf damage.

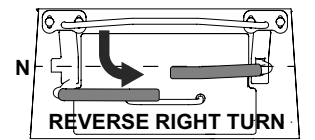

STOPPING

1. Turn PTO switch to OFF.
2. Release control traction levers or move to neutral.
3. Put machine in PARK.
4. Turn key to OFF (counterclockwise).

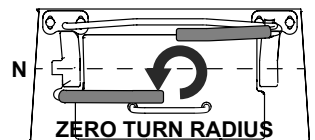
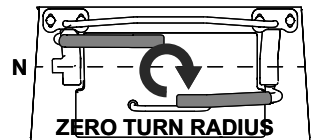
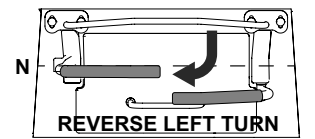

CUTTING

1. Place the discharge chute in the down position or correctly fit a grass collector or mulcher plate.
2. Sit in the seat.
3. Start the engine.
4. Turn the blades on by pulling up on the PTO switch. Do not start the blades at full throttle. Instead, use the slowest throttle setting that will allow the engine to pick up the blade load to reduce the wear on the belts and electric clutch.
5. After the blades are rotating, set the throttle to maximum. Use the traction levers to obtain the required cutting speed, to steer around obstacles and to turn at the end of a cut.

CUTTING TIPS

- When mowing large areas, start by turning to the right so that clippings will be discharged away from shrubs, fences, driveways, etc. After two or three rounds, mow in the opposite direction, left hand turns, until finished.
- If grass is extremely tall, it should be mowed twice, the first cut relatively high, the second cut to the desired height.
- Use the left side of the mower for trimming.
- Choose cutting directions so that clippings are thrown onto areas that already have been cut. This method results in the most even distribution of clippings and more uniform, better appearing cuts.
- Use a different mowing pattern each time where possible. This helps prevent rutting and leads to a more uniform cut by keeping the grass from always laying the same way.

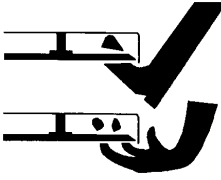
	! DANGER ROTATING BLADES - KEEP HANDS AND FEET AWAY. - STOP ENGINE AND LET BLADES STOP BEFORE REMOVING GRASS COLLECTOR OR UNCLOGGING.
--	---

	! WARNING THROWN OBJECTS - KEEP AREA CLEAR OF PEOPLE AND PETS. - REMOVE OBJECTS BLADE MAY STRIKE AND THROW. - STOP BLADES TO CROSS GRAVEL AREAS - DO NOT OPERATE WITHOUT CHUTE, MULCHER OR ENTIRE GRASS CATCHER IN PLACE.
--	---

MAINTENANCE OPERATION	Maintenance is an ongoing job. These intervals are maximum times between maintenance operations. Perform more often under severe conditions.							
	FIRST 5 HOURS	FIRST 100 HOURS	BEFORE EACH USE	EVERY 25 HOURS	EVERY 100 HOURS	EVERY 200 HOURS	EVERY 400 HOURS	YEARLY
ENGINE								
Consult the engine manual for additional information and instructions.								
Check/Top Up Oil Level			X					
Check for Leaks			X					
Clean Air Intake Screen			X					
Clean Air Cleaner Precleaner								
Clean Air Cleaner Element				X				
Clean Cooling Fins					X			
Change Oil and Filter	X	See engine manufacturer's manual						
Check/Replace Spark Plugs							X	
TRANSAXLE								
Check Oil Level	X		X					
Check for Leaks	X		X					
Change Oil and Filter		X					X	
MACHINE								
Check Interlock Operation			X					
Check Tire Pressures			X					
Check/Top Up Battery								X
Lubricate All Points			X					

NOTES

GENERAL	DATE	HRS	DATE	HRS	DATE	HRS	DATE	HRS	DATE	HRS	DATE	HRS
Check Tire Pressures												
Lubricate All Points												
Check Nuts & Bolts												
ENGINE												
Check Oil Level												
Change Oil												
Clean Air Cleaner Element												
Clean Cooling Fins												
Replace Air Cleaner Element												
Clean & Gap Spark Plugs												
TRANSAXLE												
Change Oil And Filter												
NOTE: After first 5 hours of operation change engine oil and filter.												

CHECK DAILY

Operator Presence Interlock System - Start Operation

For the engine to crank, the parking brake must be on, the PTO (blades) off and traction levers in the neutral lock position. Sit in the seat and check, one by one, if the engine will crank with the parking brake off, the blades on, and either traction lever out of neutral lock.

Operator Presence Interlock System - Run Operation

The operator must be in the seat for the engine to run with the parking brake off, the traction levers moved out of the neutral lock position, or the blades on. To check:

1. Start the engine and run at 1/2 throttle with the operator on the machine but raised off the seat.
2. One by one: move the parking brake to the OFF position, traction levers out of the neutral lock position (check each independently), and turn the blades on. Each check should kill the engine after 1/2 second. (A 1/2 second delay is built into the system to prevent engine cutout when traversing rough terrain.)

Repair machine before using if the Operator Presence Interlock System does not operate correctly in start or run. Contact your authorized Schiller Grounds Care, Inc. dealer.

Hardware

Tighten any nuts and bolts found loose. Replace any broken or missing cotter pins. Repair any other problems before operating.

Tire pressure

Rear tires should be kept inflated to 12 lbs/in² (0.8 kg/cm²). Front tires should be kept inflated to 15 lbs/in² (1.05 kg/cm²). Improper tire inflation can cause rapid tire wear and poor traction. Uneven inflation can cause uneven cutting. Over inflation of caster tires can cause casters to "wobble" on hard surfaces.

BATTERY



WARNING Battery acid is caustic and fumes are explosive and can cause serious injury or death.

NOTE: If your unit has a AGM type battery an AGM type battery charger should be used when charging.

Use insulated tools, wear protective glasses or goggles and protective clothing when working with batteries. Read and obey the battery manufacturer's instructions.

Be certain the ignition switch is OFF and the key has been removed before servicing the battery.

1. Verify battery polarity before connecting or disconnecting the battery cables.
2. When installing the battery, always assemble the RED, positive (+) battery cable first and the BLACK ground, negative (-) cable last.

3. When removing the battery, always remove the BLACK ground, negative (-) cable first and the red, positive (+) cable last.
4. Clean the cable ends and battery posts with steel wool. Use a solution of baking soda and water to clean the battery. Do not allow the solution to enter into the battery cells.
5. Tighten cables securely to battery terminals and apply a light coat of silicone dielectric grease to terminals and cable ends to prevent corrosion. Keep terminal covers in place.

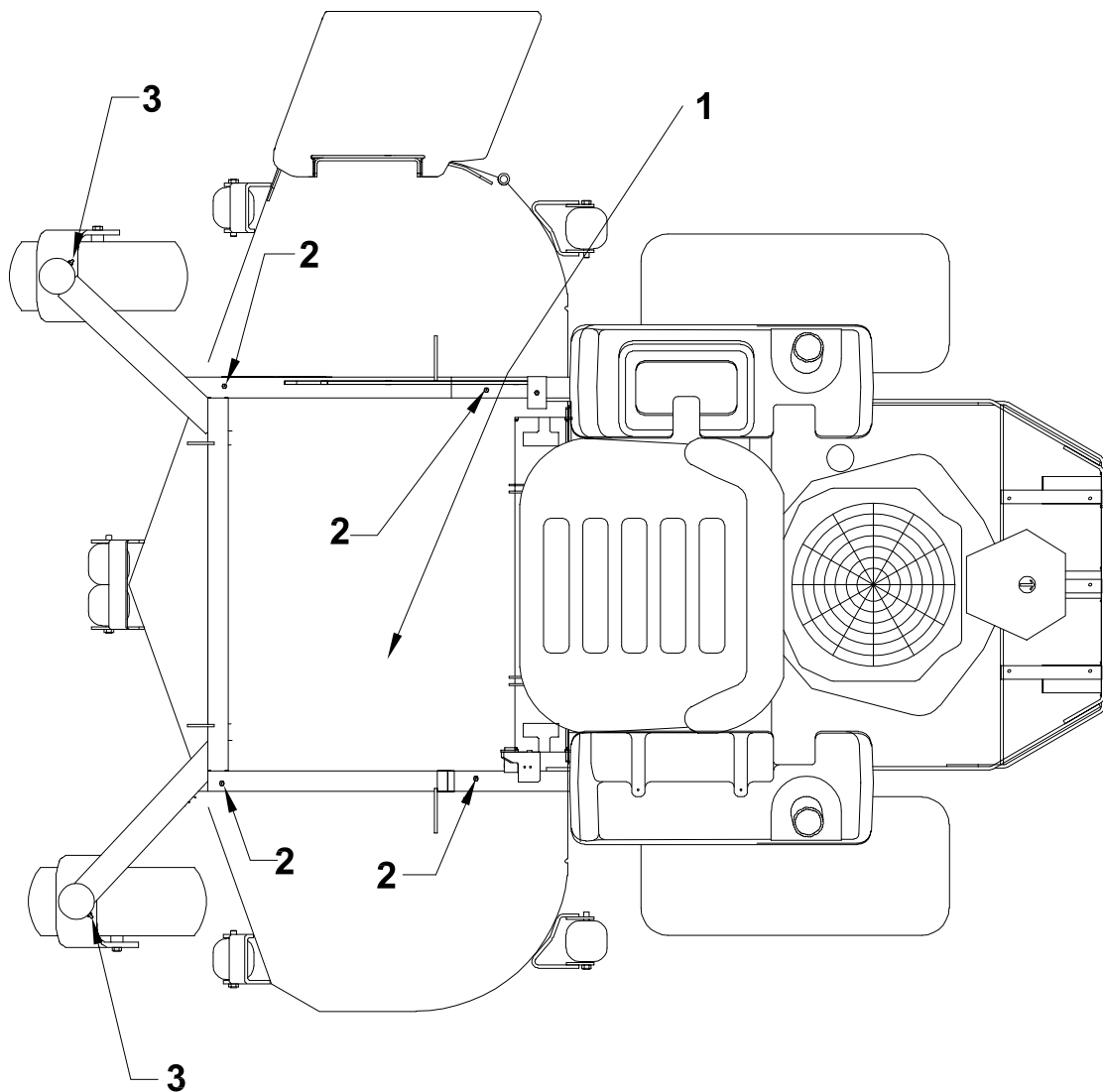

LUBRICATION

Every 50 hours of operation, lubricate the following points (1-3) with grease:

- 1. Idler Pulley (1 point-Located under footplate)
- 2. Deck lift pivots (4 points)
- 3. Caster wheel pivots (2 points)
(Lubricate every 500 hours or once a year)

NOTE ON BLADE SPINDLES - The blade spindles on these machines use a superior sealed bearing that does not require relubrication.

ENGINE OIL

Do not perform engine maintenance without the engine off, spark plug wires disconnected and PTO disengaged.

AFTER FIRST FIVE (5) HOURS

While the engine is warm:

1. Release the oil drain hose assembly from the engine clip **J**. Lay hose assembly over the frame edge or through the frame cutout, which ever is most convenient.
2. Remove the rubber cap **D** from the tip of the hose assembly and turn the drain valve to allow oil to drain from the engine. Dispose of used oil in accordance with local requirements.
3. Clean drain valve and tighten the plastic portion of the drain valve back into the metal portion of the valve. Replace rubber cap over the tip of the valve. Replace hose assembly back into engine clip.
4. Change oil filter.
5. Fill the crankcase with fresh oil to the full mark. Do not overfill. See engine manual for oil specifications.

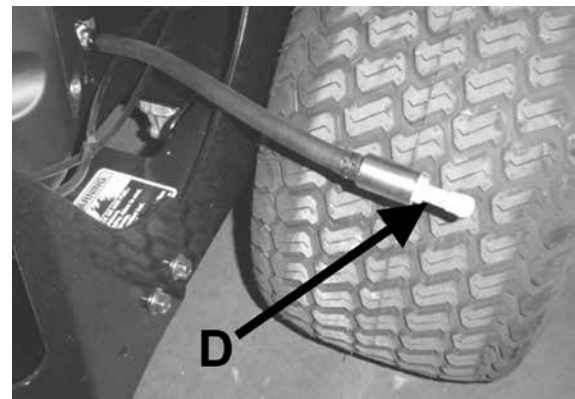

DAILY

1. Check oil level with the dipstick.
2. If oil is needed, add fresh oil of proper viscosity and grade. See engine manual for oil specifications. Do not overfill.
3. Replace dipstick before starting engine.

PERIODIC OIL CHANGES

1. See engine manual for oil and filter change intervals after the break-in period.
2. Follow instructions for first oil change, above.

SPARK PLUGS

Remove each plug and check condition.

- Good operating conditions are indicated if the plug has a light coating of grey or tan deposit.
- A white blistered coating indicates overheating. A black coating indicates an "over rich" fuel mixture. Both may be caused by a clogged air cleaner or improper carburetor adjustment.
- Do not sandblast, wire brush or otherwise attempt to repair a plug in poor condition. Best results are obtained with a new plug.
- Set plug gap as specified in engine manual..

FUEL FILTER

An in-line fuel filter is located in the fuel supply line. Inspect at every oil change to make sure it is clean and unobstructed. Replace if dirty.

AIR CLEANER

Clean and replace the air cleaner element as specified in the service chart. Uneven running, lack of power or black exhaust may indicate a dirty air cleaner.

1. Unclamp end cover **C** and remove existing cleaner element **A**.
2. Insert new element **A** and replace cover **C**. Ensure breathing port **B** is pointing down and towards the front of the tractor.

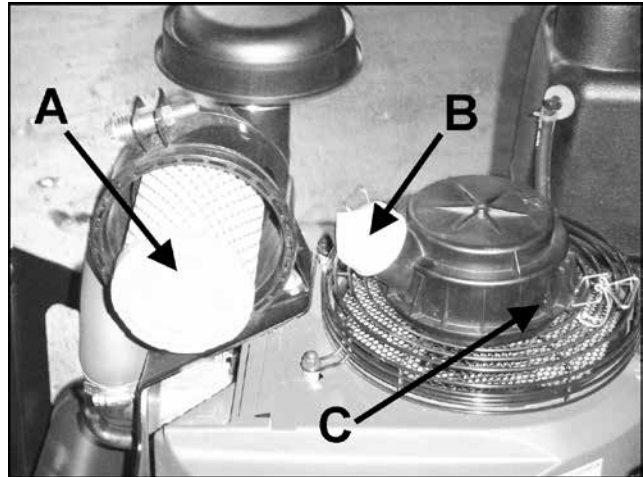

ENGINE COOLING

Continued operation with a clogged cooling system will cause severe overheating and can result in engine damage.

- **Daily:** Clean air intake screen **V**.
- **Every 100 hours:** Clean cooling fins beneath blower housing **H** with reference to information in the engine manufacturer's manual.

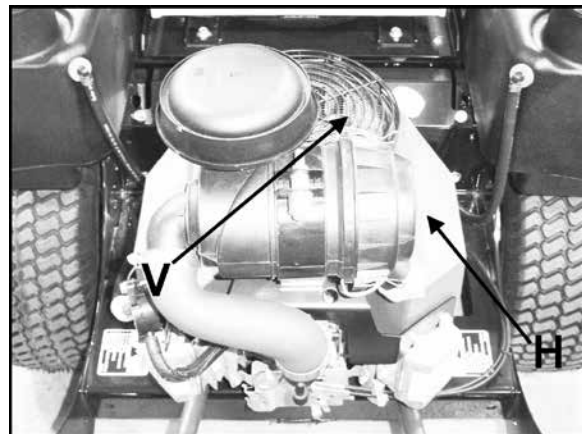

SPECIFIC TORQUES	BLADE NUTS	70 FT-LBS (95 Nm)
	WHEEL HUB NUTS	150 FT-LBS (203 Nm)
	ENGINE CRANKSHAFT BOLT	50 FT-LBS (68 Nm)
	TRANSAXLE PULLEY NUT	28.3 - 41.6 FT-LBS (38 - 56 Nm)
	TRANSAXLE DRAIN PLUG	15 - 20 FT-LBS (20 - 27 Nm)
	TRANSAXLE FILTER	130 - 150 in-lbs (14.6 - 16.9 Nm)

<p>PURGING TRANSAXLES</p> <p>Due to the effects air has on efficiency in hydrostatic drive applications, it is critical that it be purged from the system.</p> <p>These purge procedures should be implemented any time a hydrostatic system has been opened to facilitate maintenance or any additional fluid has been added to the system.</p> <p>Purging may be required if the unit shows any of the following symptoms:</p> <ul style="list-style-type: none"> - Noisy operation. - Lack of power or drive after short term use. - High operation temperature, excessive oil expansion. 	<ol style="list-style-type: none"> 1. Check the transaxle fluid, fill to proper level, if required. 2. Raise the drive wheels off the ground. Support unit with jackstands or other suitable means. 3. With the bypass valves open, and the engine running, slowly move the control levers in both forward and reverse directions 5 to 6 times. As air is purged from the unit, the oil level will drop. 4. With the bypass valve closed, and the engine running, slowly move the control levers in both forward and reverse directions 5 to 6 times. 5. Stop engine. Check the transaxle fluid level, add fluid as required. 6. It may be necessary to repeat steps 3-5 until all the air is completely purged from the system. When the transaxle moves forward and reverse at normal speed, purging is complete.
--	---

<p>CLEANING MACHINE</p> <p>Clean the machine after use. The machine will run cooler and last longer if kept free of clippings and other debris. A clean machine also reduces the risk of fire due to accumulation of combustible debris and chaff</p> <p>Brush or blow clippings and debris off the cutterdeck and engine deck.</p>	<p>WASHING MACHINE</p> <p>CAUTION: Improperly washing a machine can cause water to enter bearings and other components. This can greatly reduce component life.</p> <ul style="list-style-type: none"> - Do not use a pressure washer. Do not direct water at bearings or seals. High pressure water can blow past seals and enter seal bearings. - Allow the machine to cool down before washing. Water on a warm machine can be sucked into sealed bearings as they cool. - Avoid getting electrical connections wet. Water can cause electrical faults and corrosion of electrical components.
--	--

TRANSAXLES

⚠ WARNING

Inattention to proper safety, operation, or maintenance procedures could result in personal injury, or damage to the equipment. Schiller Grounds Care, Inc. recommends returning the machine to your authorized Schiller Grounds Care, Inc. dealer for service or repair. Change oil and filter after initial 75-100 hours. Then every 400 hours thereafter.

Perform transaxle maintenance with the engine off, spark plug wires disconnected and PTO disengaged.

TRANSAXLE FLUID CHANGE

Change the transaxle fluid every 400 hours of operation or once a year. It is essential that the exterior of the transaxle be free of debris, prior to fluid maintenance.

1. Remove the three 1/4" filter guard screws and filter guard **A**. Remove the oil filter **B** from the transaxle and discard. Dispose of used oil in accordance with local requirements.
2. Wipe the filter base surface off and apply a film of new oil to the gasket of the new replacement filter. Install the new filter by hand, turn 3/4 to one full turn after the filter gasket contacts the filter base surface.
3. Re-install the filter guard and torque the three screws to 65 in. lbs. each.
4. Remove cap **C**, fill the transaxles through the expansion tank **D** with approximately 2 quarts of SAE 20W-50 engine oil PER TRANSAXLE.

CAUTION

Do not overfill! If you overfill the transaxle while the unit is "cold", it may overflow as it reaches normal operating temperatures. The oil level should not be above the manufacturer's suggestions. The oil level should be filled no higher than the Cold Fill Line. This will allow the space needed for the oil to expand as it warms up.

5. After starting engine, check the fluid level and continue to add oil to overflow tank **D** to fill line on tank.
6. Purge the transaxles, following the purging procedures on Page 27.

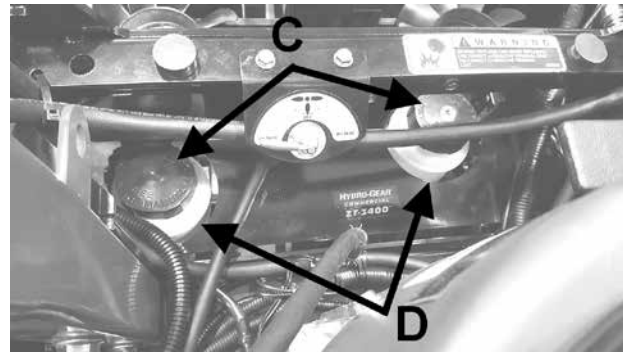
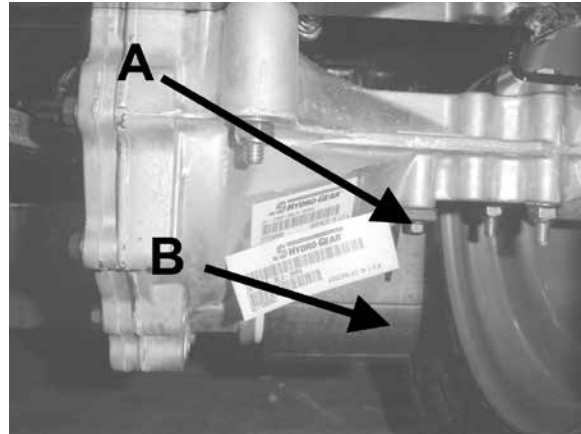

BLADE REMOVAL

Follow these instructions to prevent injury during blade removal:

1. Loosen with a box wrench or a socket and long breaker bar. To gain additional leverage, slip a long pipe or thick-walled tube over breaker bar or wrench.
2. Insert wood block **A** as shown, with grain perpendicular to blade, to prevent blade from turning when loosening.
3. Wear thickly padded gloves. Keep hands clear of blade path. Blades may rotate when bolt releases.

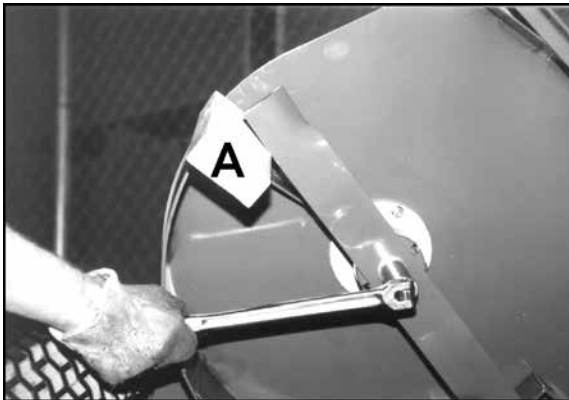

SHARPENING

Blades may be sharpened by filing or grinding.

- Inspect blades before sharpening.
- Replace bent or cracked blades.
- Replace blades when the lift portion has worn thin.
- Maintain cut angle at 30°.
- Do not overheat blades when sharpening.
- Always use Schiller Grounds Care, Inc. blades. Use of another manufacturer's blades may be dangerous.

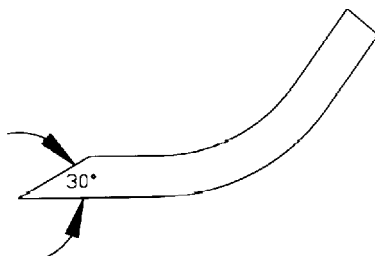

BLADE BALANCE

Blade balance must be maintained at 5/8 oz-in (19.4 g-cm) or less. Failure to keep blades balanced causes excess vibration, wear, and shortened life of most components of the machine.

To balance a blade:

1. Sharpen blade first.
2. Balance the blade at the center.
3. Attach a 1/8 oz (3.9 g) weight at a distance 5" (127 mm) from center on the light end. This should make the light end the heavy end:
 - If it does, the blade is balanced.
 - If does not, file or grind the heavy end until the addition of the weight makes the light end the heavy end.

BLADE INSTALLATION

1. Wear thickly padded gloves to prevent cuts from the sharp blade.
2. Insert the blade, conical washer (cup side toward the blade, as shown), and the blade nut onto the spindle shaft.
3. Hold top spindle nut with wrench and torque bottom nut to 70 ft-lbs.

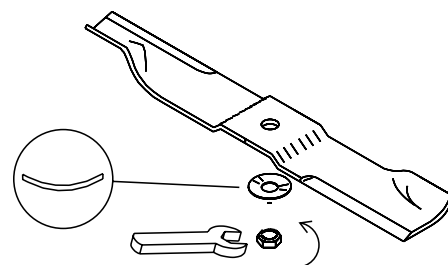

DECK LEVELING

1. Park the machine on a smooth, level surface. Raise the deck to the transport position.
2. Lower the deck onto a set of equal height blocks under the rear corners of the deck. Place another set of blocks under the front of the deck so that the deck top is pitched forward 1/8".
3. Measure the height of the blade cutting edge above the ground. Remove pin **A** and set the pin in the corresponding position to that height.
4. Loosen nuts on bolts **G**. Move bolts in slot to help position deck. Tighten nuts on bolts **G**.

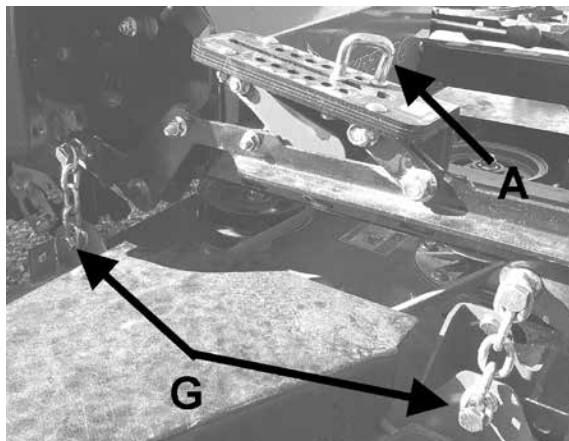

A 1/8" forward pitched deck provides the best horsepower.
 A level deck provides the best quality of cut.
 A 1/8" rearward pitched deck provides the best striping.
 Certain grass types and conditions may vary.

HEIGHT OF CUT

The height of cut is set by moving height of cut pin **A** to the hole designated for the height of cut desired.

To change the height of cut:

1. Lift the deck to the highest position using the foot lift pedal.
2. Move pin **A** to the selected hole.
3. Lower the deck until the latch lever **E** is stopped by the pin.

NOTES:

- Height of cut may vary due to the amount of tread on the tires, tire diameter or inflation pressure.
- For best results, adjust the rear deck rollers for the height of cut to be used (see below).

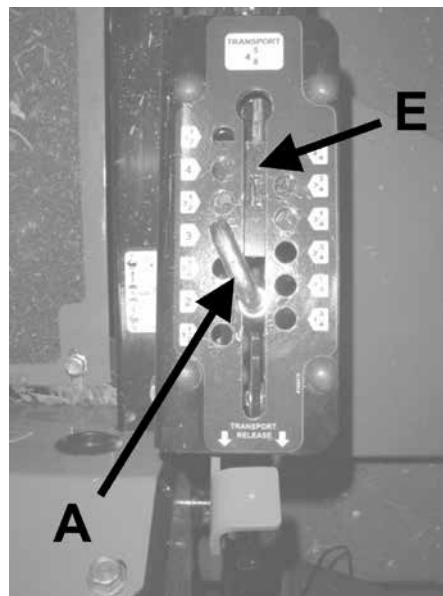

DECK ROLLERS

The deck rollers are adjustable up and down to provide improved deck flotation and scalping protection at various heights of cut. They are not intended to ride continuously on the ground. Adjust no closer than 3/8" (10mm) to the ground.

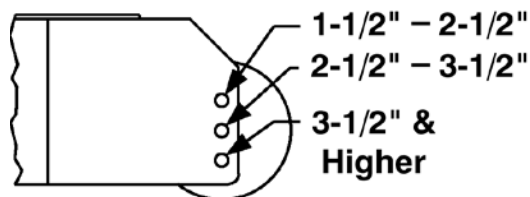

Height of cut ranges for roller adjustment

PARKING BRAKE

NOTE: There are 2 brakes, 1 on each transaxle.

The parking brake should keep the machine from moving. To check the parking brake, park the machine on a level surface, open the bypass valves and set the parking brake to **ON**. Attempt to move the machine forward and backward by pushing it. If the machine moves, adjust the parking brake linkage as follows:

1. Move the machine to a flat horizontal surface.
2. Move the parking brake handle to the OFF position.
3. Remove cotter pin **P** from each brake link **K** and brake rod **R**. Slide brake rod **R** out of each brake link **K** and insure that the brake links are rotated toward the rear of the machine. Reinsert rod **R** into each link **K** and secure with cotter pin **P**.
4. The parking brake handle should be approximately horizontal when in the Off position. If the brakes need to be adjusted, loosen the inner nut **M** of the brake rod **B**. Tighten the outer nut **L** as needed for the brakes to be engaged. Tighten inner nut **M**.
5. Tighten brake nut **N** as needed. The length of the threads protruding past the nut should measure 1/4" - 3/8".
6. Retest to insure the machine does not move.

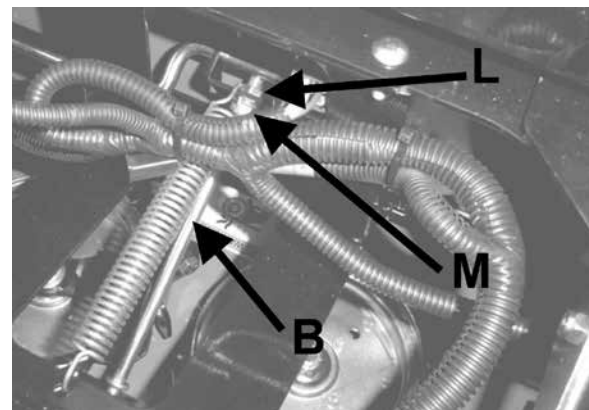
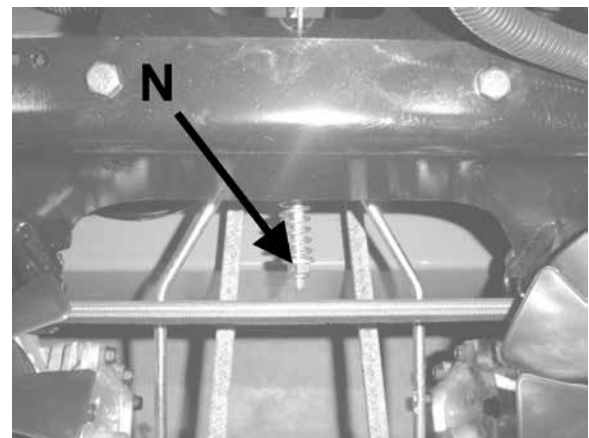
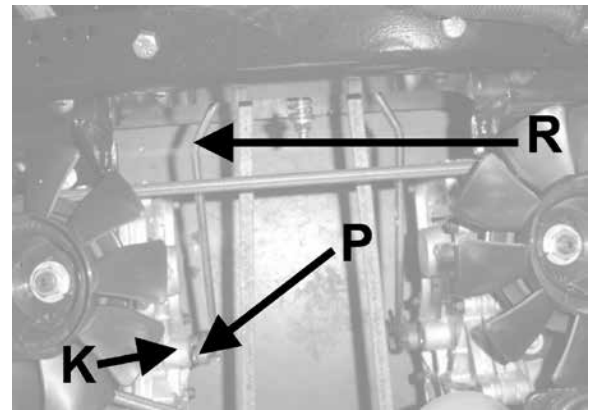

HYDROSTATIC TRANSAXLE ADJUSTMENTS

A turnbuckle style hydrostat neutral adjustment is provided.

Neutral:

1. Support the machine with the rear wheels off the ground. Use jackstands or equivalent support. Do not rely only on mechanical or hydraulic jacks.
2. Move the traction levers out into the neutral lock position and raise the seat.
3. Disconnect the seat switch wire and temporarily connect the two terminals with a jumper wire.
4. Start the engine and run at low speed.
5. Move parking brake to the **OFF** position.
6. Loosen jam nuts **K** at both ends of the control rod **L**.
7. Rotate the control rod until the corresponding wheel stops turning. Lock the control rod jam nuts. Run the engine up to high idle and stroke the traction levers forward and back to check the adjustment. Move traction levers back to neutral and readjust if necessary.
8. Repeat steps 6 and 7 for the opposite side.
9. Remove the jumper wire and reconnect the seat switch.

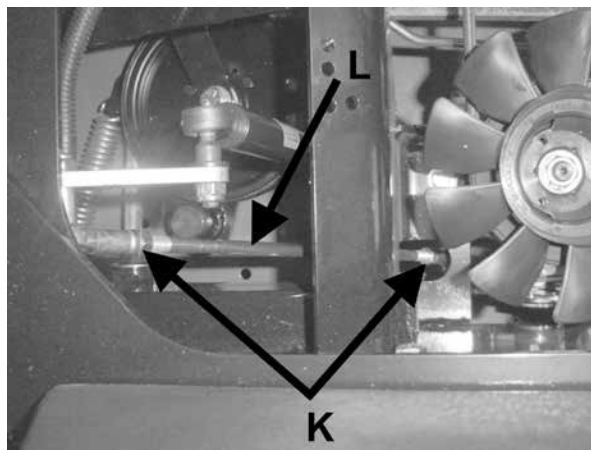
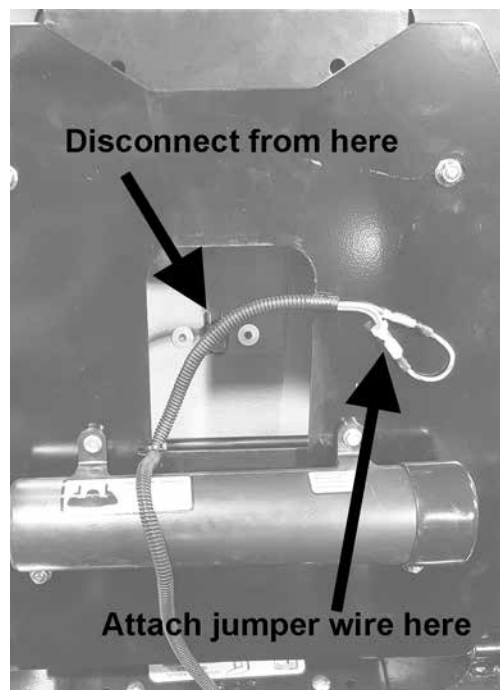

NOTE: Always use Schiller Grounds Care, Inc. replacement belts, not general purpose belts. Schiller Grounds Care, Inc. belts are specially designed for use on this mower and will normally last longer.

CUTTERDECK BELT

1. Remove floorplate.
2. Set the cutterdeck in a middle height-of-cut position.
3. Use a 3/8" ratchet and extension to back tensioning idler off to remove belt from idler. Remove belt from cutterdeck pulleys.

NOTE: Use the 3/8" ratchet in the square hole **A** on the idler.

4. Remove belt from clutch pulley.
5. Install the new belt by performing these steps in reverse order.

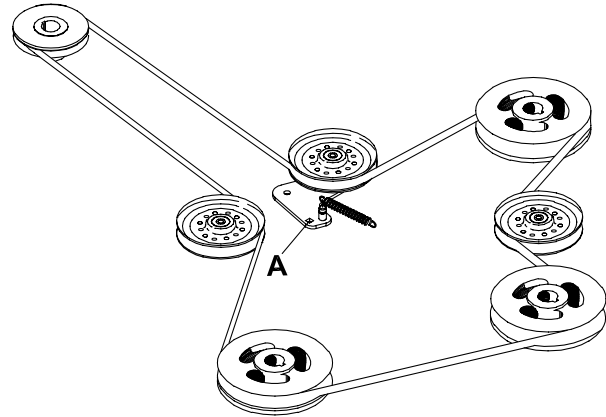

3 SPINDLE DECK

BELT TENSION

NOTE: 61" cutterdeck may require tension spring adjustment after belt installation. See Belt tension below.

BELT TENSION FOR 61" DECK

All belts are tensioned by spring loaded idlers and do not require any adjustment except for the 61" cutterdeck. Use the eyebolt to adjust the spring length to be between 6 3/4" - 7 1/2" as pictured.

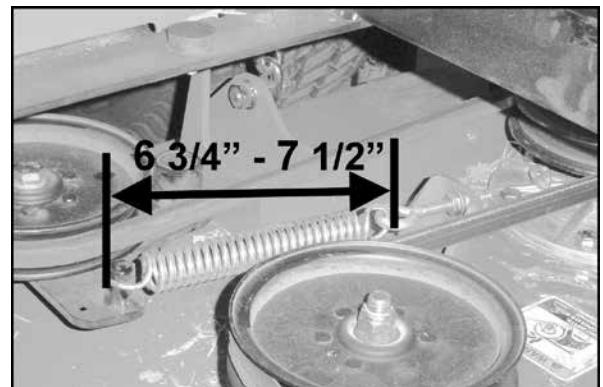

HYDRO TRANSAXLE DRIVE BELT

1. Remove cutterdeck belt (see cutterdeck belt replacement).
2. Disconnect wire **I** at clutch **M**. Remove bolts **J** and remove torque restraint.
3. Using a ratchet with a 9/16" socket, place over nut at location **P**. Use the ratchet to rotate it enough to remove the transaxle drive belt.
4. Install a new transaxle drive belt by performing these steps in reverse order.
5. Inspect the fans. Replace if worn or damaged. Torque transaxle pulley nut to 28.3-41.6 ft-lbs (38-56 Nm).
6. Reinstall cutterdeck belt (see cutterdeck belt replacement).

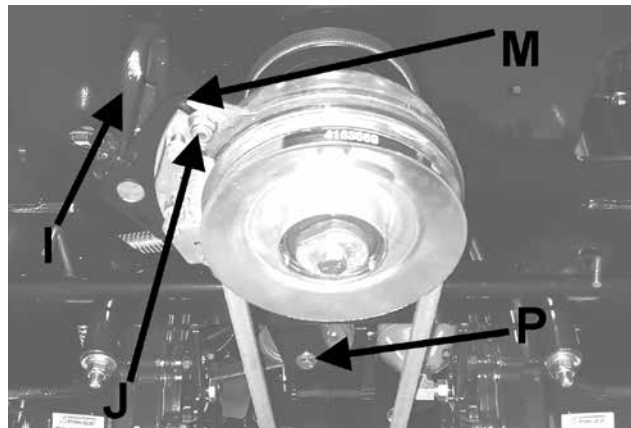

SEAT

1. The seat is adjustable. From the operator's position, push the seat lever **Q** toward the left and slide the seat forward or backward to the desired location.
2. Have the seat in the rear most position prior to tilting.

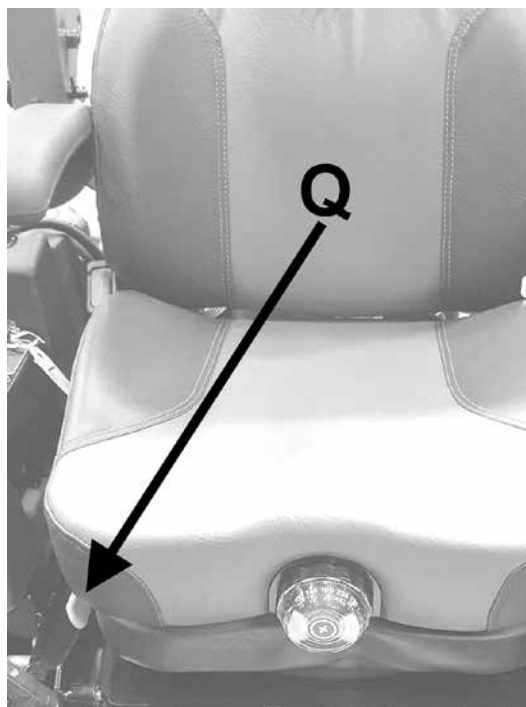

PARTS SECTION

FRAME-ENGINE/CLUTCH ASSY

XRZ PRO RS

FIGURE 1

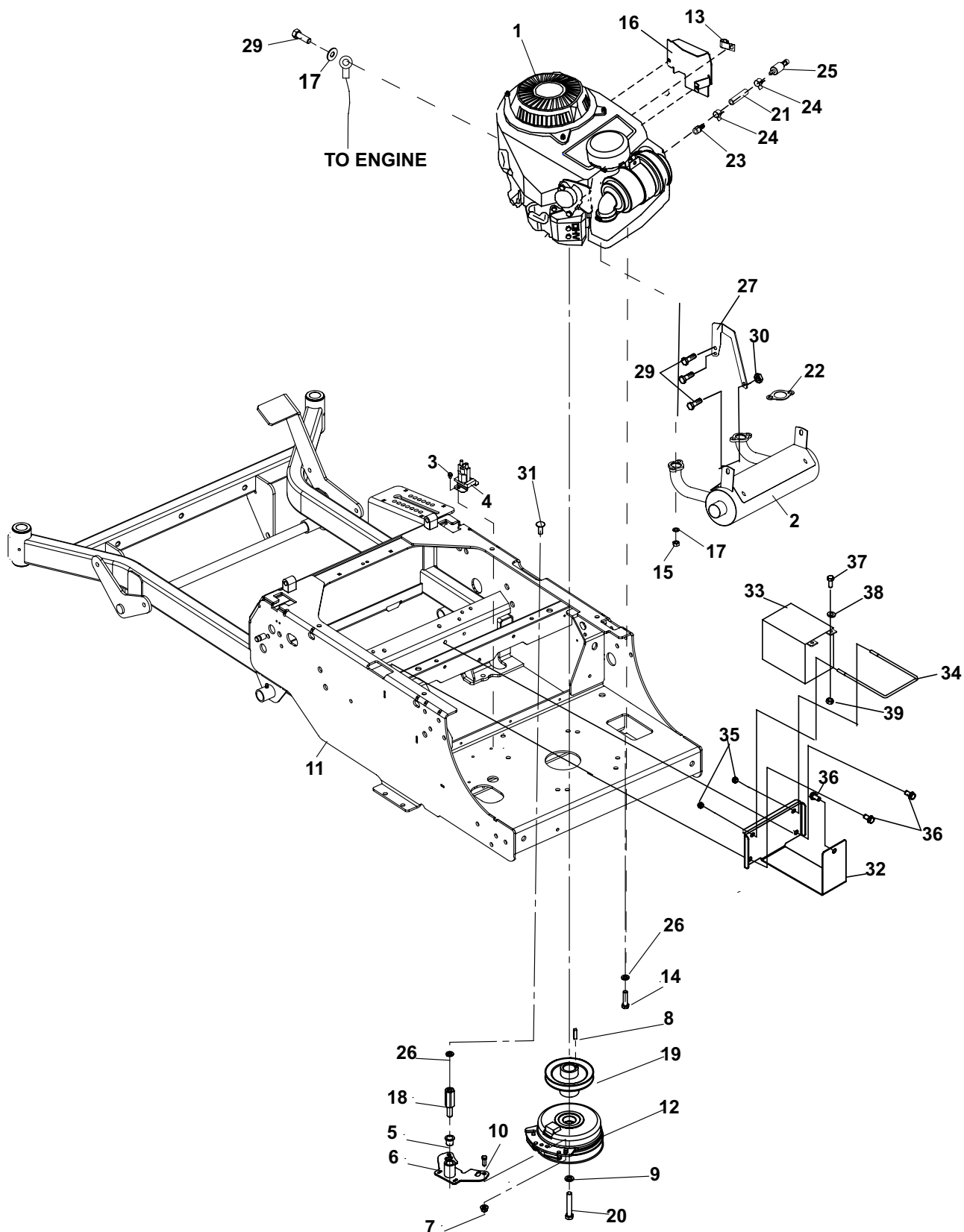

FIGURE 1

ITM	PART NO.	DESCRIPTION	QTY	ITM	PART NO.	DESCRIPTION	QTY
1	4164367	ENGINE-FX691V KAW (MODEL 942631)	1	19	4163309	PULLEY-ENGINE	1
	4164366	ENGINE-FX651V KAW (MODEL 942630)	1	20	64123-78	BLT-HEX 7/16-20X2-1/2	1
	4164368	ENGINE-FX730V KAW (MODEL 942632)	1	21	69053-05	HOSE, HYDRAULIC 12"	1
	4164576	S-AIR FILTER PRIMARY		22	11060-7016	GASKET-MUFFLER (AVAILABLE FROM KAWASAKI DEALER)	2
	4164577	S-AIR FILTER SAFETY		23	4164251	VALVE-OIL DRAIN	1
	4164537	FILTER-OIL		24	88042-03	CLAMP-HOSE	2
	4168368	FILTER-FUEL		25	4164252-001	FITTING-3/8NP TO BARB	1
	4175174	ENGINE-FX850V KAW (MODELS 942633 & 942634)	1	26	64006-03	LOCKWSHR-3/8 HELICAL	5
	4168368	FILTER-FUEL		27	4164442.7	BRKT-MUFFLER, RH (USED ON 942630, 942631, 942632)	1
	4152953	FILTER-AIR PRIMARY			4163124.7	BRKT-MUFFLER, RH (MODELS 942633 & 942634)	
	4152954	FILTER-AIR SAFETY		28	4164443.7	BRKT-MUFFLER, LH (USED ON 942630, 942631, 942632)	1
	2722214	FILTER-OIL			4163123.7	BRKT-MUFFLER, LH (MODELS 942633 & 942634)	
2	4164385	MUFFLER -KAW 22-26HP (MODELS 942630, 942631, 942632)	1	29	64263-007	BLT-FLG HD M8-1.25 X 20	7
	4163089	MUFFLER -KAW 27HP-29HP (MODELS 942633 & 942634)	1	30	64266-02	NUT-FL LOCK M8-1.25	2
3	64152-23	1/4-20X3/8 LG SP SCREW (MODELS 942630 & 942631)	2	31	64018-44	BLT-CRG 3/8-16 X 1	1
4	38665	SOLENOID (MODELS 942630 & 942631)	1	32	4167258.7	TRAY-BATTERY	1
5	38304-03	BRG-FLANGED PLASTIC	1	33	4171099	BATTERY	1
6	4173452.7	WLDMT-CLUTCH STOP	1	*	4171973	CHARGER-BATTERY, AGM	
7	64265-04	LOCKNUT-M8-1.25	2	34	4167239	ROD-BATTERY CLAMP	1
8	64164-12	KEY-1/4X1/4X1 SQ END	1	35	64268-02	NUT-FL NYLON LOCK 5/16-18	2
9	64006-06	LOCKWASHER-HEL 7/16	1	36	64197-022	BLT-TDFM 3/8-16X3/4	3
10	64205-001	BLT-MET M8-1.25X20	2	37	64262-002	BLT-FLG HD 1/4-20 X 3/4	2
11	4175451	S-FRAME , 48" & 52"	1	38	64163-03	WSHR .256ID X.62OD X 18 GA	2
	4175452	S-FRAME, 61"	1	39	64025-01	NUT-HEX 1/4-20	2
12	4168822	CLUTCH-ENGINE PULLEY (MODELS 942630, 942631, 942632)	1				
	4171141	CLUTCH-ELECTRIC 200FTLB (MODELS 942633 & 942634)	1				
13	48412-01	CLAMP	1				
14	64123-70	BLT-HEX 3/8-16X1-1/2	4				
15	64207-01	NUT-HEX M8-1.25	4				
16	4165312.7	DEFLECTOR-ENGINE AIR USED ON MODELS 942633 & 942634 ONLY	1				
17	64006-2	LOCKWASHER-HELICAL M8	5				
18	4169106	PIN-CLUTCH	1				

*** NOT ILLUSTRATED**

TRANSAXLE ASSY

XRZ PRO RS

FIGURE 2

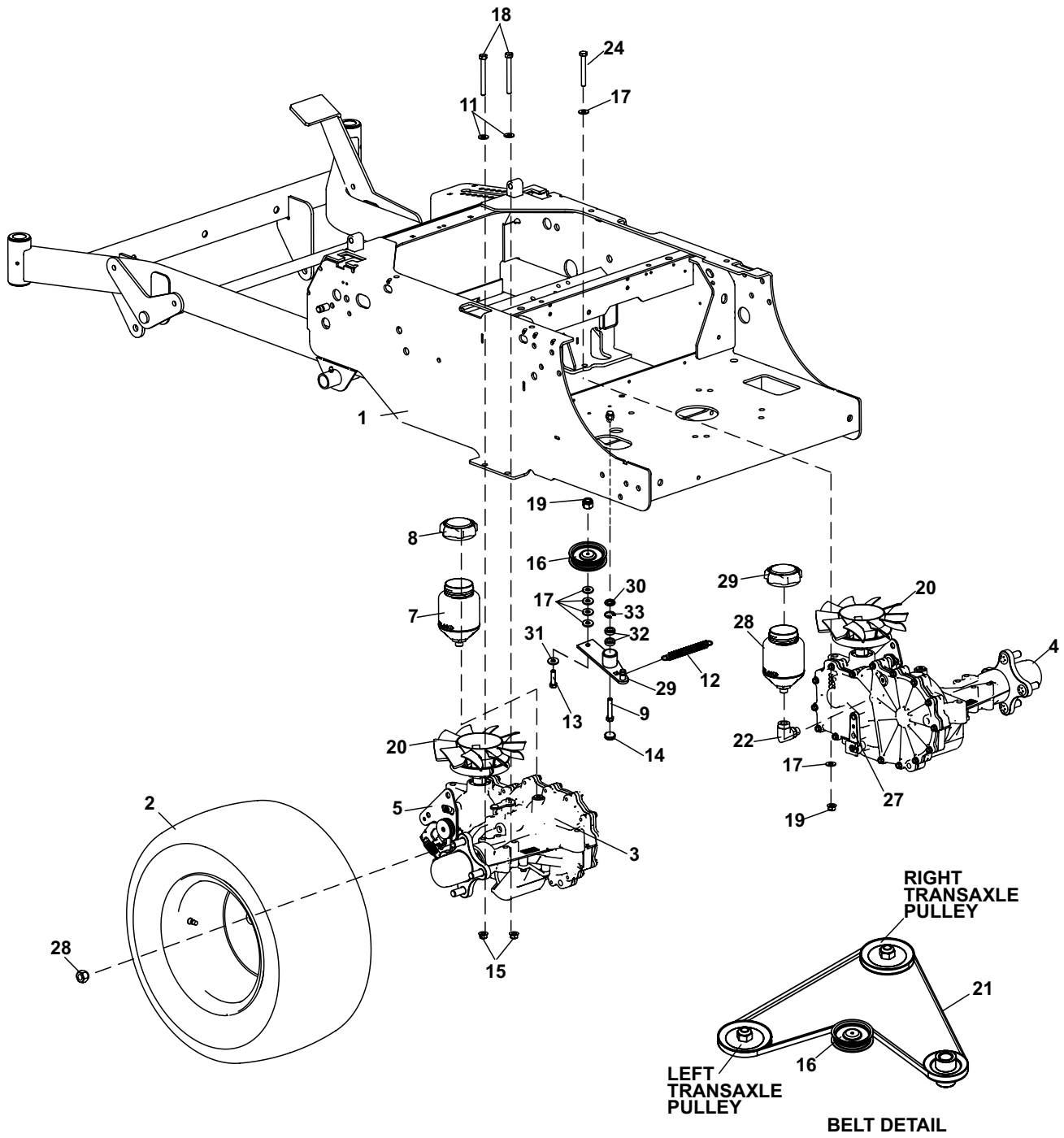
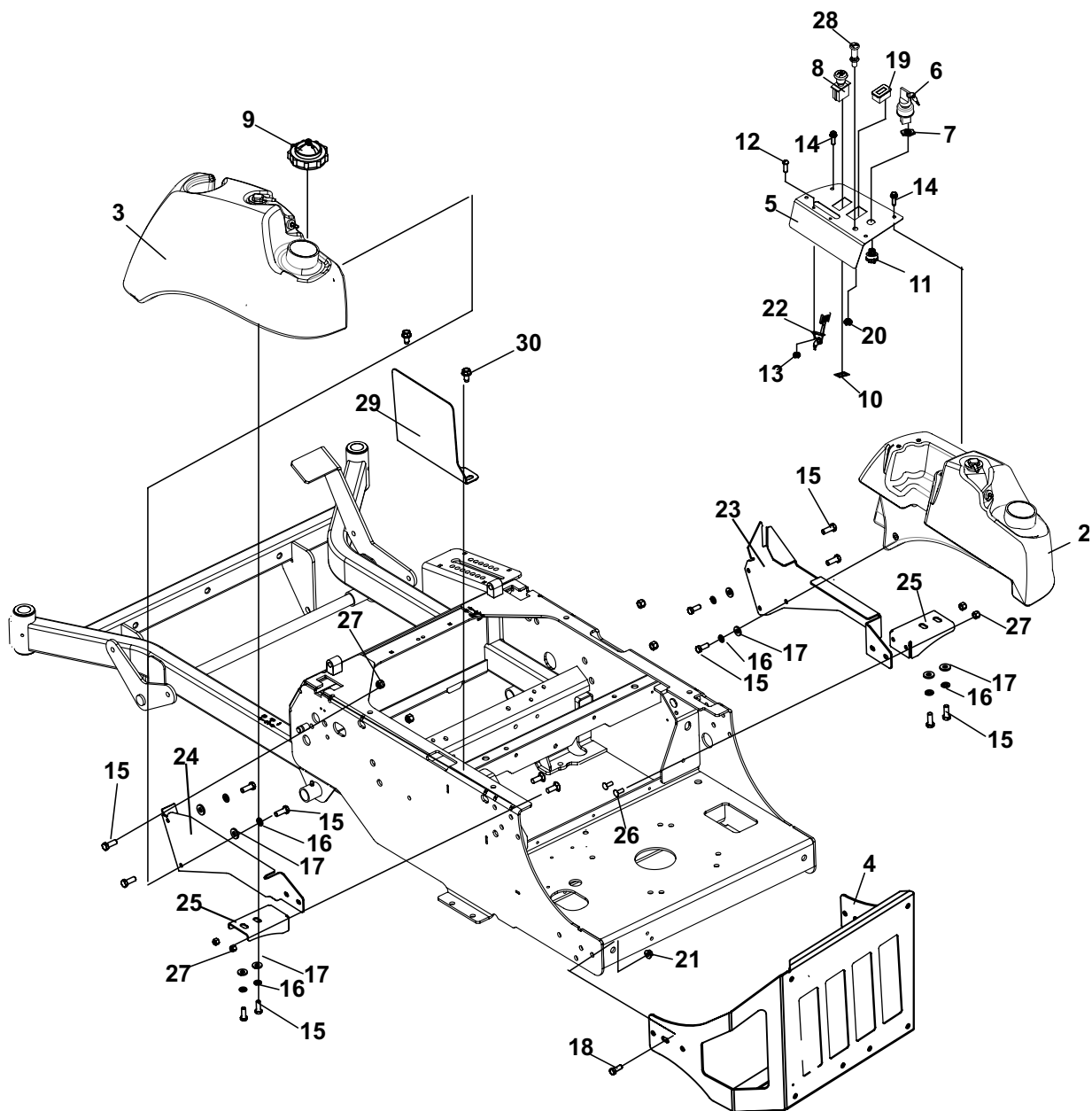

FIGURE 2

ITM	PART NO.	DESCRIPTION	QTY	ITM	PART NO.	DESCRIPTION	QTY
1	4175451	S-FRAME , 48" &52"	1	27	4163820	ARM-BRAKE	2
	4175452	S-FRAME, 61"			4164862	CLIP-RETAINING (USE WITH BRAKE ARM)	2
2	4175261	WHEEL-ASSY,23X10.50-12	2	28	64187-03	NUT-WHEEL	8
	4171868-01	TIRE-23X10.5-12 OTRT		29	4133302	S-ASY, IDLER ARM PUMP (INCLUDES 30, 32, 33)	1
	4175261-01	RIM-12X8.5, BLACK (USED ON 942630, 942631, 942633)		30	4128000	SEAL-16X26X7	1
	4175248	WHEEL-ASSY,23X10.50-12 BLK	2	31	64163-61	WASHER	1
	4171868-01	TIRE-23X10.5-12 OTR		32	4128004	BEARING-BALL 10X26X8	2
	4175248-02	RIM-12X8.5 BLACK (USED ON 942632, 942634)		33	64144-40	SNAP RING-26MM INTERNAL	1
3	4163771	TRANSAXLE-LH (INCLUDES 5, 10, 20, 25-27)	1				
4	4163772	TRANSAXLE-RH (INCLUDES 6, 8, 10, 20, 25-27)	1				
*	970438	KIT-WHEEL HUB PULLER					
5	4163819	KIT ARM-CONTROL	1				
6*	4164228	KIT CHARGE PUMP COVER	1				
7	4168619	ASSY-EXPANSION TANK	2				
8	4142808-01	CAP-HYDROTANK	2				
9	64270-01	BOLT-MET, HEX M10-1.5x30	1				
10*	4163771-01	GUARD-FILTER LH	1				
11	64163-55	WASHER .328X.75X14 GA	4				
12	4164128	SPRING-TENSION	1				
13	64123-67	BLT-HEX 3/8-16 X 2	1				
14	4128001	END CAP-24 X 7	1				
15	64268-02	NUT-FL NYLON LOCK 5/16-18	4				
16	2228016	PULLEY-IDLER PUMP	1				
17	64163-31	WASHER, 25/64X1X12	12				
18	64123-55	BLT-HEX 5/16-18X3	4				
19	64268-03	NUT-FL NYLON LOCK 3/8-16	5				
20	4164129	KIT-FAN/PULLEY TRNSXL	1				
21	4143636	BELT-TRANSAXLE	1				
22	4163264-01	ADAPTER-90#6 ORB/#6 ORB	1				
23*	4163772-01	GUARD-FILTER RH	1				
24	64123-88	BLT-HEX 3/8-16X2-3/4	4				
25*	4142045-06	FILTER-TRANSAXLE	2				
26*	4163819	SPRING-CONTROL ARM	2				

* NOT ILLUSTRATED

FIGURE 3



XRZ PRO RS BUMPER, FUEL TANK & CONTROL PANEL

FIGURE 3

ITM	PART NO.	DESCRIPTION	QTY	ITM	PART NO.	DESCRIPTION	QTY
1	4175451	S-FRAME , 48" &52"	1				
	4175452	S-FRAME, 61"					
2	4176843	TANK-FUEL RH	1				
3	4176844	TANK-FUEL LH	1				
4	4171767.7	BUMPER	1				
5	4166245	S-CONTROL PANEL	1				
6	128010-03	S-COVERED KEY	1				
7	128010-01	S-KEY SWITCH NUT 5/8-32	1				
8	2721505	SWITCH-PTO	1				
9	4165291	CAP-FUEL TANK	2				
10	2188178	SWITCH-RETAINER	1				
11	128010	SWITCH, KEY	1				
12	64152-46	SCREW-SLT HH 10-24X1/2	2				
13	64025-15	NUT-HEX #10-24 KEPS	2				
14	64262-001	BLT-FLG HD 1/4-20 X 1/2	4				
15	64123-50	BOLT-3/8-16X1 HEX	12				
16	64006-03	WASHER-3/8	8				
17	64163-69	WASHER-FLAT	8				
18	64262-010	BLT-FLG HD 3/8-16 X 3/4	4				
19	4168452	METER-HOUR	1				
20	64025-04	NUT-HEX 3/8-24	1				
21	64141-4	NUT-WLF 3/8-16	4				
22	118020-23	CONTROL-THROTTLE	1				
23	4175115.7	BRKT-TANK, SPACER, RH	2				
24	4175114.7	BRKT-TANK, SPACER, LH	2				
25	4175126.7	BRKT-MOUNT TANKS	2				
26	64018-44	BLT-CRG 3/8-16 X 1	4				
27	64229-03	NUT-NYLON LOCK 3/16-18	8				
28	108009-09	CABLE-CHOKE	1				
29	4175384.7	BRKT-L, TANK	1				
30	64197-016	BLT-TDFM 3/8-16X1/2	2				

* NOT ILLUSTRATED

FIGURE 4

ITM	PART NO.	DESCRIPTION	QTY	ITM	PART NO.	DESCRIPTION	QTY
1	4175451	S-FRAME , 48" &52"	1				
	4175452	S-FRAME, 61"					
2	4176843	TANK-FUEL RH BOBCAT (INCLUDES 10-13)	1				
3	4176844	TANK-FUEL LH BOBCAT (INCLUDES 10-13)	1				
4	64152-23	BLT-HEX 1/4-20 x 3/8	4				
5	4174731.7	COVER-FRAME, REAR	1				
6	88042N	HOSE CLAMP	10				
7	4162977-021	HOSE-1/4 FUEL LINE 25"	2				
8	2188161	VALVE-TANK SELECTOR	1				
9	4165291	CAP-FUEL TANK	2				
10	4132325	GROMMET-FUEL TANK	2				
11	4165503-05	TUBE-PICK UP	2				
12	4165387	GROMMET-ROLL OVER	2				
13	4165763	ROLLOVER VENT	2				
14	4174224	FITTING-TEE, 1/4X1/4X3/16	1				
15	4162977-010	HOSE-1/4 FUEL LINE 24"	1				
16	4162977-020	HOSE-FUEL LINE 31.5"	2				
17	4162989-001	HOSE-FUEL LINE 36"	1				
18	88042-01	CLAMP	2				
19	4174901.7	BRKT-TANK SELECTOR VALVE	1				
20	48228-12	CLAMP3-4 CLIP	2				
21	64229-02	LOCKNUT-5/196-18	2				
22	64123-54	BLT-HEX 5/16-18 X 3/4	2				

FIGURE 5

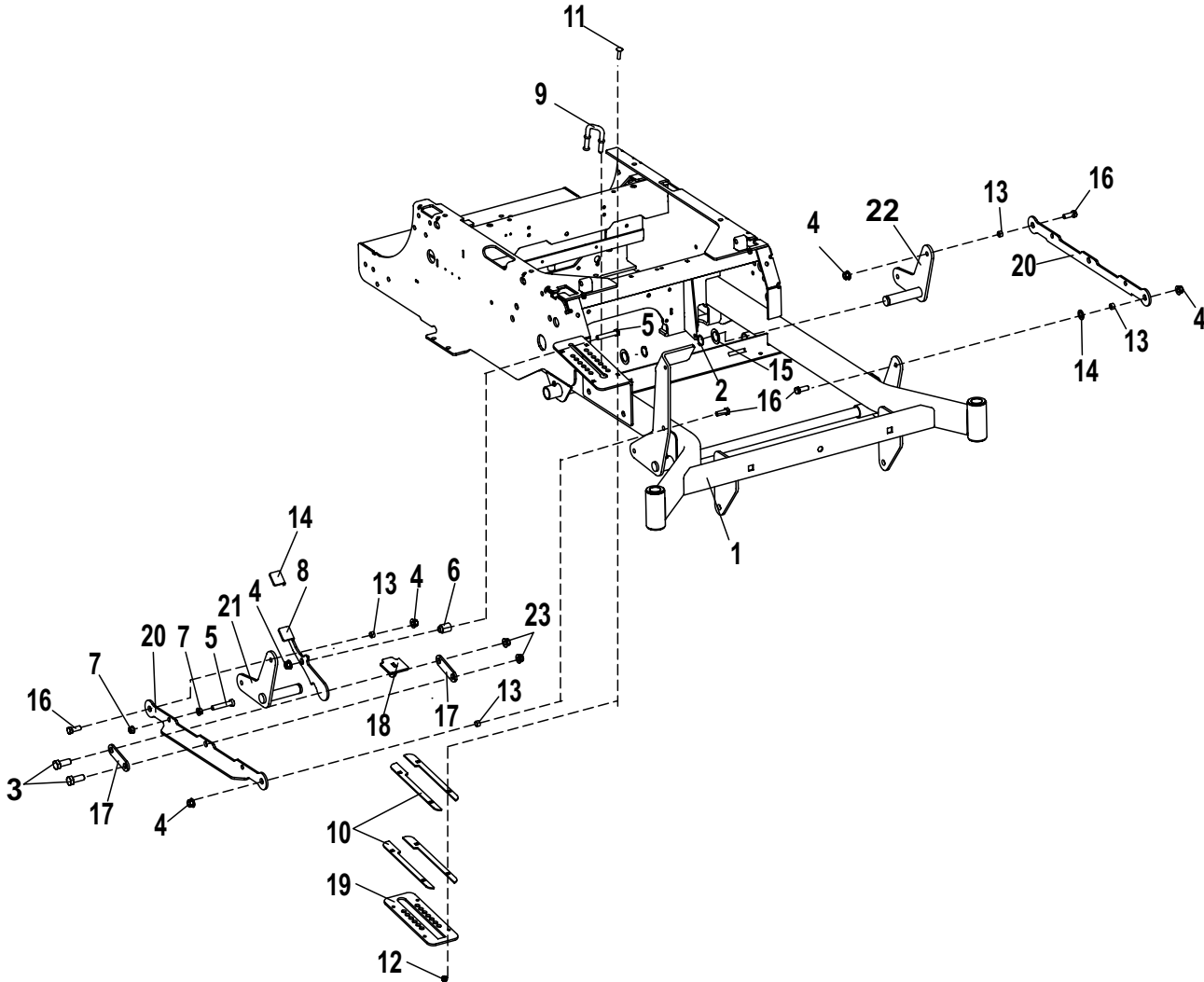

FIGURE 5

ITM	PART NO.	DESCRIPTION	QTY	ITM	PART NO.	DESCRIPTION	QTY
1	4175451	S-FRAME, 48/52"	1				
	4175452	S-FRAME, 61"					
2	64144-03	SNAP RING-7/8"	2				
3	64123-39	BLT--CARRIAGE 1/2-13 X 1-1/4	2				
4	64268-03	NUT-FL NYLON LOCK 3/8-16	5				
5	64123-87	BLT-HEX 3/8-16 1-3/4	2				
6	4168335	SPACER-TANSPORT RELEASE	1				
7	64141-4	NUT-WLF 3/8-16	2				
8	4169229.2	LATCH-TRANSPORT	1				
9	4168338	STOP-WIRE FORM, UPGRADE	1				
10	4167982.7	PLT-STACKER, 2	4				
11	64018-42	1/4-20 X 1	4				
12	64229-01	NUT-NYLON LOCK 1/4-20	4				
13	4174948-01	SPACER-DECK LINK	4				
14	4169398	GRIP-LATCH TRANSPORT	1				
15	64163-65	WSHR-.890X1.375X18GA	2				
16	64262-012	BLT-FLG HD 3/8-16 X 1-1/4	4				
17	4168181.7	PLT-LINK, HEIGHT ADJUST	2				
18	4167994.7	WLDMT-HEIGHT ADJ SLIDER	1				
19	4167983.7	PLT-SLIDER MNTG	1				
20	4175393.7	ANGLE-DECK LIFT	2				
21	4175269.7	WLDMT-STUBSHAFT, RH	1				
22	4175268.7	WLDMT-STUBSHAFT, LH	1				
23	64268-05	NUT-FL NYLON LCK 1/2-13	2				

*NOT ILLUSTRATED

FIGURE 6

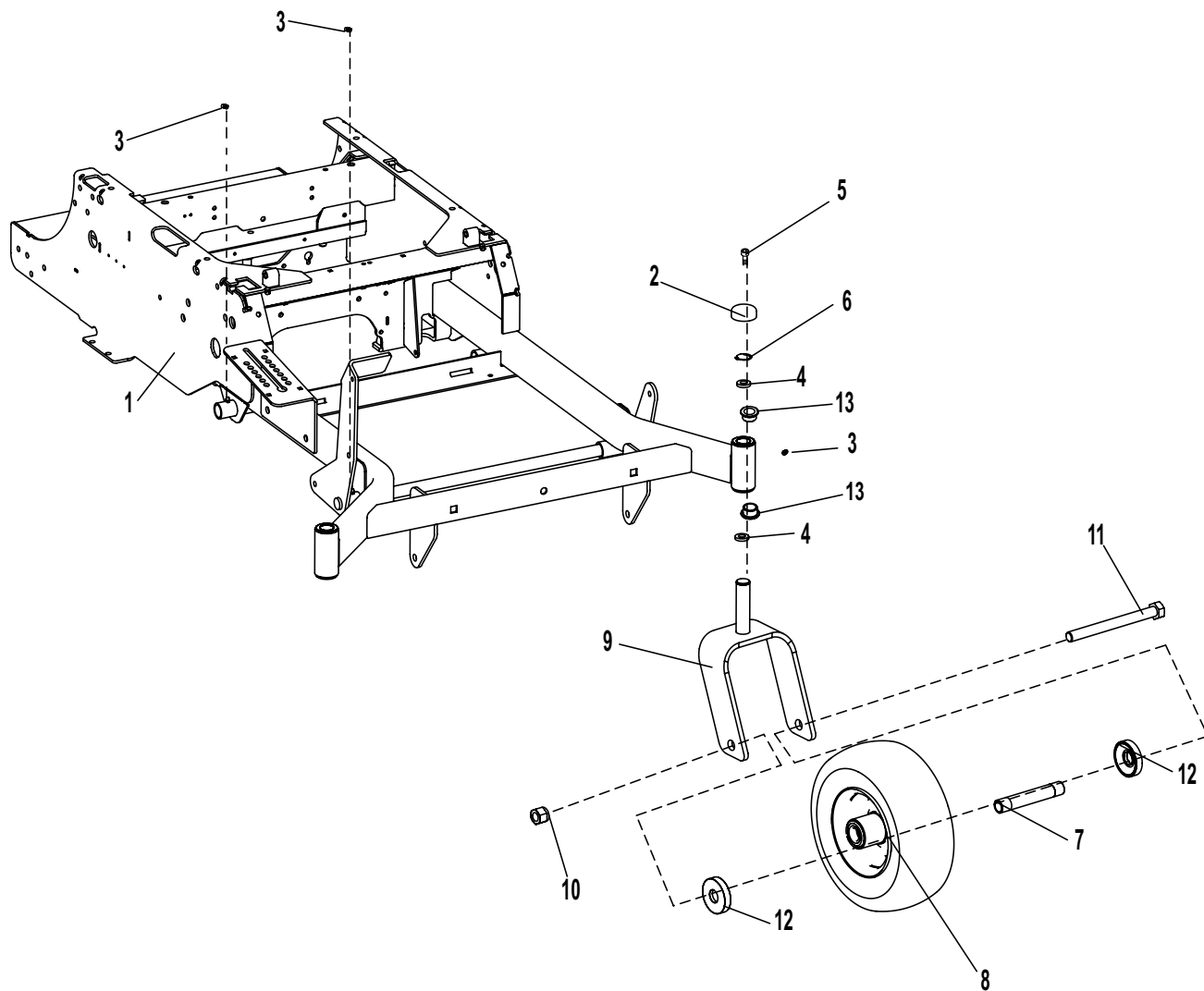

FIGURE 6

ITM	PART NO.	DESCRIPTION	QTY	ITM	PART NO.	DESCRIPTION	QTY
1	4175451	S-FRAME 48"-52"	1				
	4175452	S-FRAME 61"					
2	4171802	CAP-CASTER	2				
3	4168424	ZERK-1/4-28	6				
4	64163-64	WSHR 1.015X1.500X14GA	4				
5	64272-04	SCRW-FL HEX 5/16-18 X 3/4	2				
6	64144-24	SNAP RING 1.00 EXT	2				
7	2722230-03	SPANNER-X6.5 WHEEL	2				
8	4175255	WHEEL-13X6.5-6	2				
9	4175112.7	WLDMT-CASTER	2				
10	64229-07	NUT-NYLON LOCK 3/4-10	2				
11	64123-223	BLT-HEX 3/4-10X10	2				
12	2722231	SPACER-END	4				
13	4129801	BUSHING-FLANGED	4				

KICKPLATE/SEAT ASSEMBLY

XRZ PRO RS

FIGURE 7

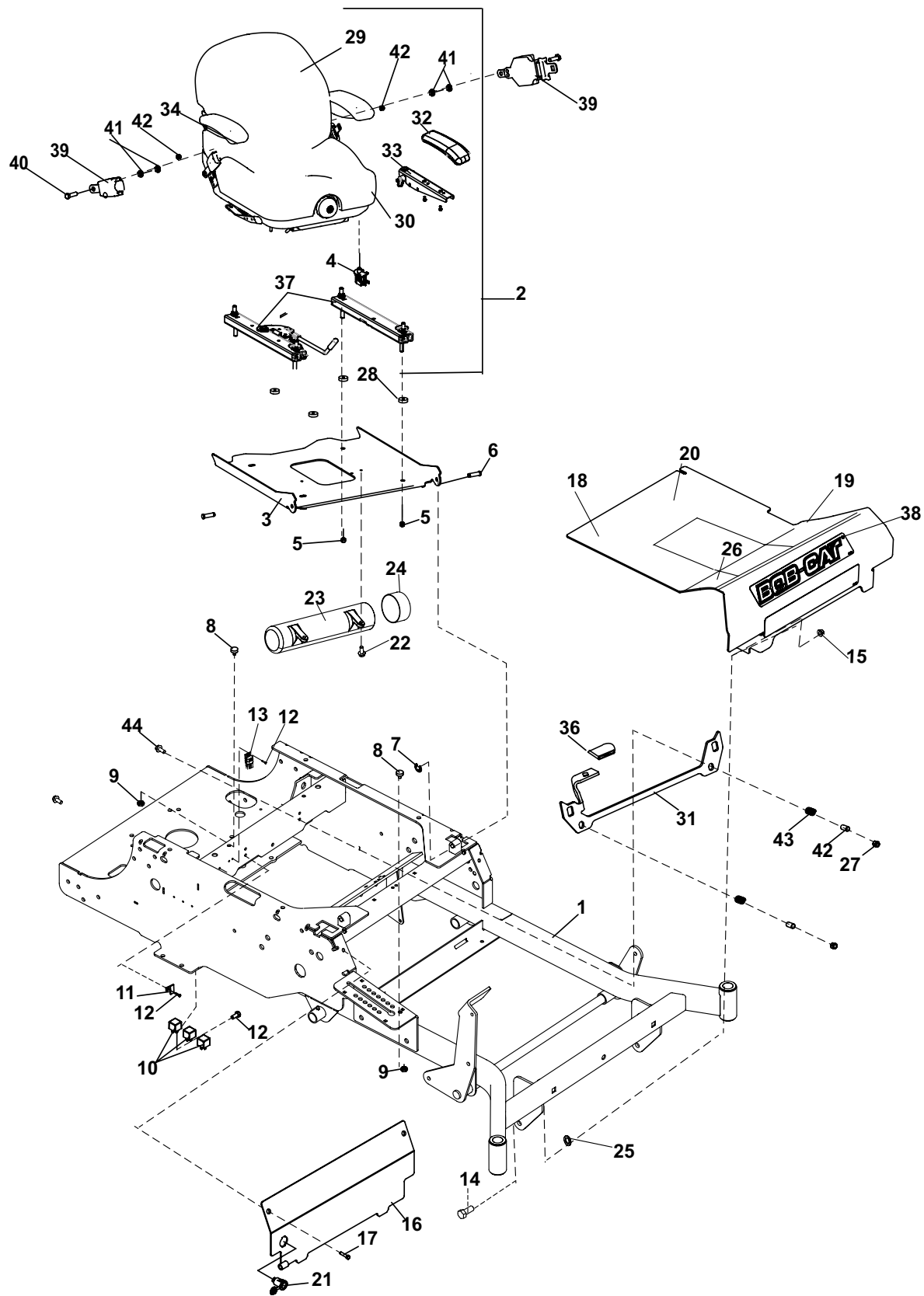

FIGURE 7

ITM	PART NO.	DESCRIPTION	QTY	ITM	PART NO.	DESCRIPTION	QTY
1	4175451	S-FRAME 48"-52"	1	26	4167087	MAT-FOOTPLATE RH UPPER	1
	4175452	S-FRAME 61"		27	64268-03	NUT-FL NYLON LOCK 3/8-16	2
2	4175334	SEAT ASSY. (INCLUDES ITEMS 28-35, 37, 39)	1	28	2720975-07	SPACER-NYLON 3/8IN	4
3	4175223.7	PLATE-SEAT	1	29	4175334-01	COVER-BACK w/ LOGO	1
4	4124009	SWITCH-SEAT NO	1	30	4175334-02	COVER-BOTTOM	1
5	64268-02	NUT-NY LOCK 5/16-18	4	31	4175228.7	BRKT-LATCH STOP	1
6	33138-09	PIN-CLEVIS GRVD .38 X 1.31	2	32	4165316-02	PAD-ARM SINGLE	2
7	64144-30	SNAP RING .375	2	33	4169768-02	ARM KIT-LH	1
8	4143354	BUMPER, SEAT MOUNTING	4	34	4169768-07	ARM KIT-RH	1
9	64141-6	NUT-5/16-18	4	35*	4169768-08	KIT-ARM RH & LH (INCLUDES ITEMS 33 & 34)	1
10	2722325	RELAY-40AMP SEALED	3	36	4167151	COVER-HANDLE	1
11	148082-20	FUSE-20 AMP	2	37	4169768-04	TRACKSET	1
12	64197-032	BLT-TDFM 10-24X1/2	7	38	4164406	LABEL- BOB CAT	1
13	2188154	MODULE-DELAY	1	39	4175334-03	KIT-SEAT BELT (INCLUDES ITEM 40 & 41)	1
14	64123-16	BLT-HEX 3/8-16X1-1/4	2	40	64123-216	BLT-HEX 7/16-20X2-1/4	2
15	64229-03	NUT-NYL LOCK 3/8-16	2	41	4167820-02	SPACER-SEAT BELT	1
16	4164549.2	PLATE-FRONT REMOVABLE	1	42	516544	BUSHING (PLATED)	2
17	64197-016	BLT-TDFM 3/8-16X1/2	2	43	41-053	SPRING-COMP .631X 1.125	2
18	4175454	S-FOOT PLATE (INCLUDES ITEMS 19, 20, 26, 27,38)	1	44	64123-87	BLT-HEX 3/8-16X1-3/4	2
19	4167088	MAT-FOOT PLATE LH UPPER	1				
20	4165931	MAT-FOOT PLATE LOWER	1				
21	4142266	CONNECTOR-12V RECEPT	1				
22	64197-002	BLT-TDFM 1/4-20X3/4	2				
23	4129802	TUBE-DOCUMENT	1				
24	38061A	CAP-VINYL	1				
25	64163-46	WSHR.383/.393X.88X7GA	2				

*** NOT ILLUSTRATED**

FIGURE 8

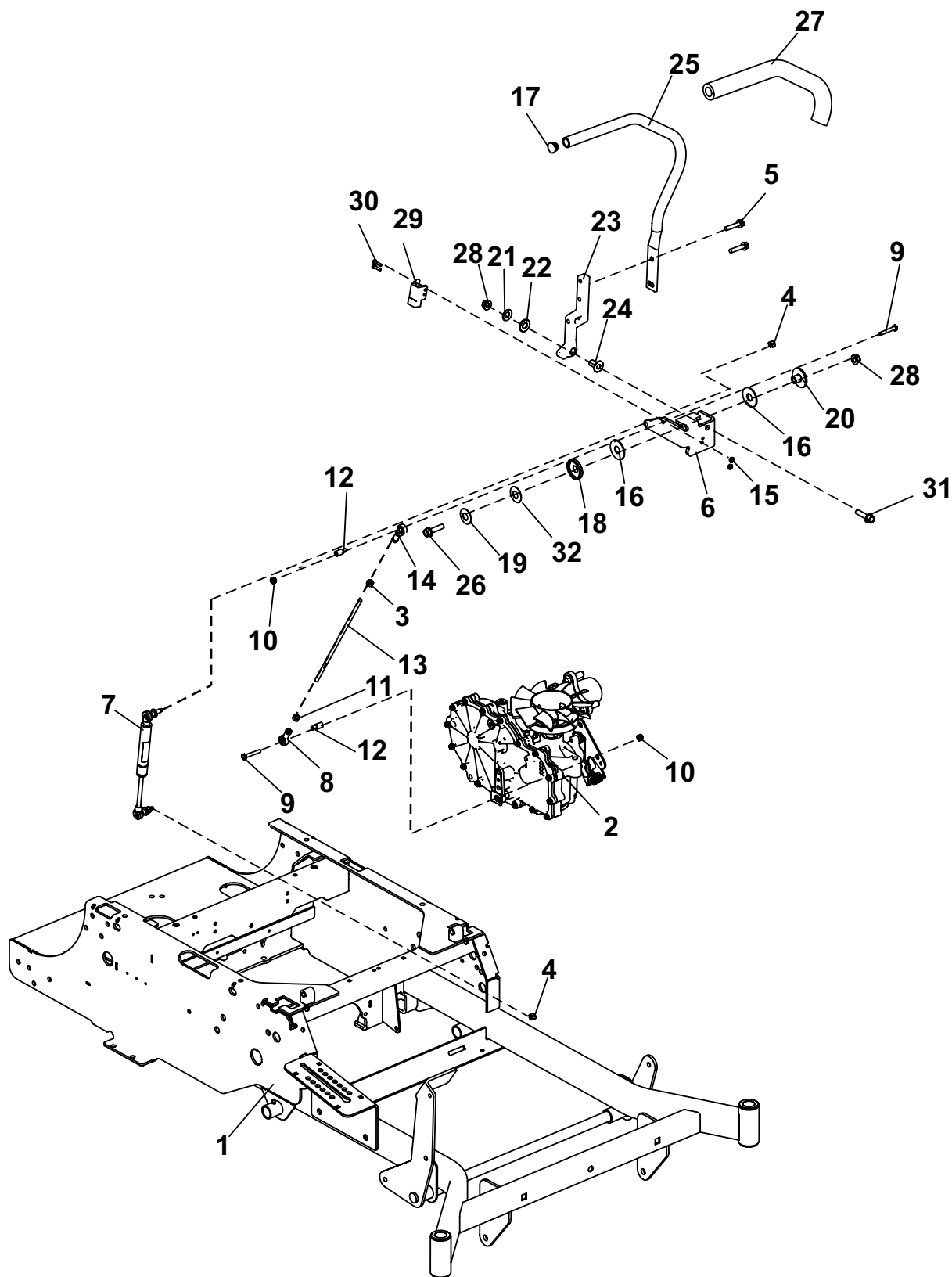

FIGURE 8

ITM	PART NO.	DESCRIPTION	QTY	ITM	PART NO.	DESCRIPTION	QTY
1	4175451	S-FRAME, 48/52"	1				
	4175452	S-FRAME, 61"					
2	4163771	TRANSAXLE-LH	1				
	4163772	TRANSAXLE-RH	1				
3	64025-03	NUT-HEX 5/24	2				
4	64229-02	NUT-NYLON LOCK 5/16-18	6				
5	64262-006	BLT-FLG HD 5/16-18 X 3/4	4				
6	4171278	PLT-CONTROL BOX, LH	1				
	4171279	PLT-CONTROL BOX, RH	1				
7	4165499	DAMPER	2				
8	4143595-01	ROD END-FEMALE	2				
9	64123-60	BLT-HEX 1/4-20X2	4				
10	64229-01	NUT-NYLON LOCK 1/4-20	4				
11	64025-33	NUT-HEX 5/16-24 LH	2				
12	4168814	SPACER-CONTROL ROD	4				
13	4143571	ROD-CONTROL	2				
14	4143595-02	ROD END-FEMALE, LH	2				
15	64025-15	NUT-HEX #10-24 KEPS	4				
16	4168126	WASHER-FLAT, DELRIN	4				
17	4163692	CAP-TUBE END	2				
18	4168328	WASHER - CUPPED	2				
19	4168434	WASHER-BELLVILLE, 625 ID	2				
20	4168327	SPACER-CONTROL LEVER	2				
21	4168435	WASHER-BELLVILLE, 512 ID	2				
22	4168346	WASHER-CUP, LUBRICATING	2				
23	4170389	BAR-CONTROL, PM	2				
24	4168345	SPACER-CTL ARM,	2				
25	4175657.7	HANDLE-, ADJUSTABLE	2				
26	64262-013	BLT-FLG HD 3/8-16 X 1-1/2	4				
27	4165432	GRIP-CONTROL ARM	2				
28	64268-03	NUT-FL NYLON LOCK 3/8-16	4				
29	108208	SWITCH-DBL POLE NC/NO	2				
30	64152-49	SCREW-SLT HH 10-24X3/4	4				
31	64262-018	BLT-FLG HD 3/8-16 x 1-3/4	2				
32	4168823	SHIM	2				

* NOT ILLUSTRATED

PARKING BRAKE

XRZ PRO RS

FIGURE 9

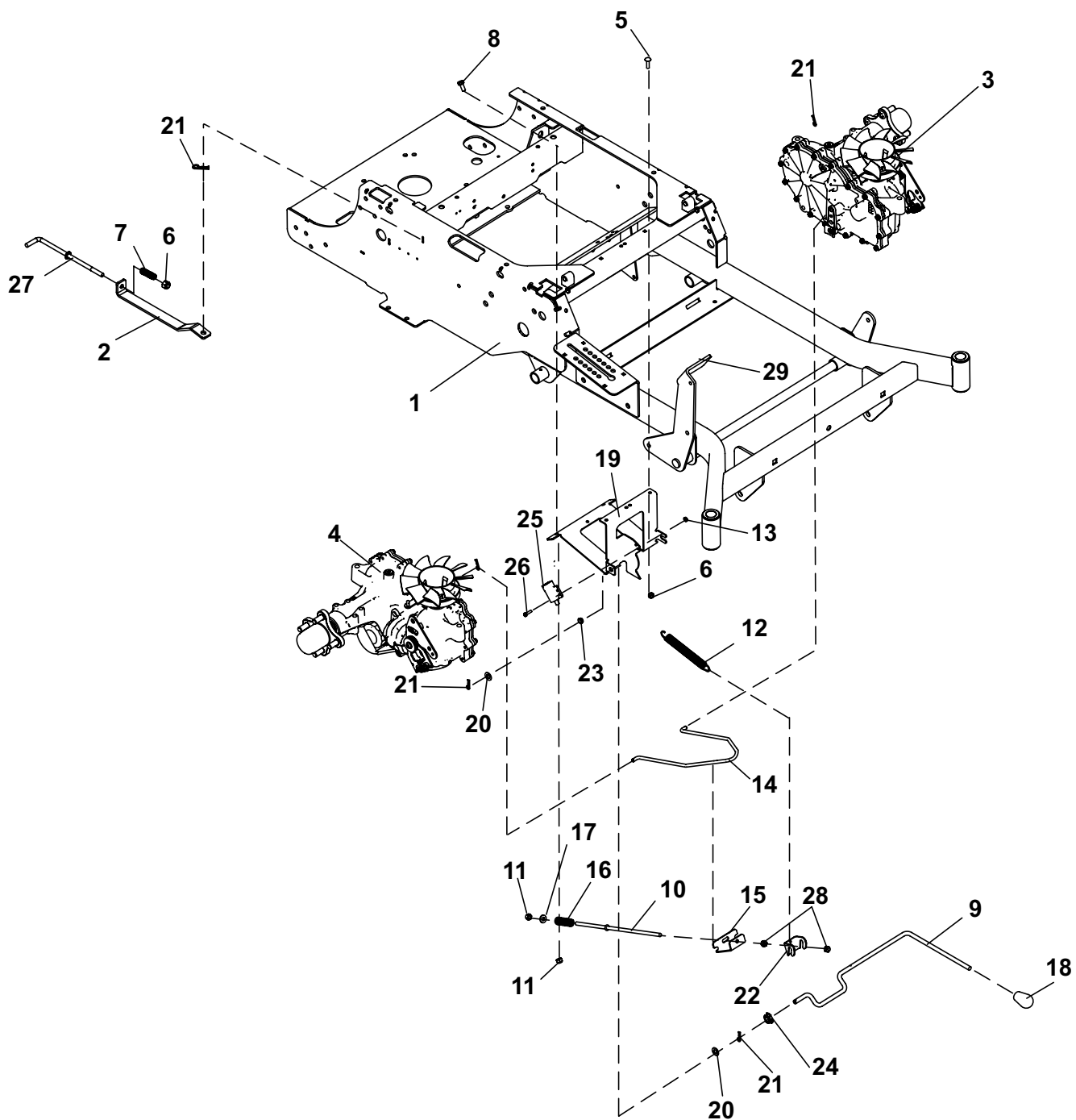

FIGURE 9

ITM	PART NO.	DESCRIPTION	QTY	ITM	PART NO.	DESCRIPTION	QTY
1	4175451	S-FRAME, 48/52"	1				
	4175452	S-FRAME, 61"					
2	4148698.7	LINK-DUMP VALVE	2				
3	4163771	TRANSAXLE-LH	1				
4	4163772	TRANSAXLE-RH	1				
5	64018-2	BLT-CRG, 1/4-20 X 3/4	2				
6	64229-01	NUT-NYLON LOCK 1/4-20	4				
7	2720977	SPRING-COMPRESSION	2				
8	64123-54	BLT-HEX 5/16-18 X .75	2				
9	4168162	LEVER-BRAKE, WIRE-FORM	1				
10	4168171	ROD-BRAKE, THRD, 5/16	1				
11	64229-02	NUT-NYLON LOCK 5/16-18	3				
12	41-010	SPRING	1				
13	64025-15	NUT-HEX #10-24 KEPS	2				
14	4168163	ROD-BRAKE, PARKING	1				
15	4168217.7	BRACKET-CLIP, RETAINER	1				
16	4155481	SPRING COMPRESSION	1				
17	64163-55	WSHR-.328X.75X14 GA	1				
18	4168180	KNOB-PUSH ON	1				
19	4168209.7	BRACKET-BRAKE, PARKING	1				
20	64163-61	WSHR .81X.406X16GA	2				
21	64168-2	COTTER-HAIRPIN .08X1.19	6				
22	4168210.7	CLIP-RETAINING, LINK	1				
23	4168216	BUSHING-PARKING BRAKE	1				
24	4168412	BEARING-BRAKE, PARKING	1				
25	2188156	SWITCH-NONO DBL POLE	1				
26	64152-49	SCREW-SLT HH 10-24X3/4	2				
27	4148697	ROD-BYPASS CONTROL	2				
28	64141-6	NUT-WLF 5/16-18	2				
29	4139785	MAT-FOOT LIFT	1				

WIRE HARNESS

XRZ PRO RS

FIGURE 10

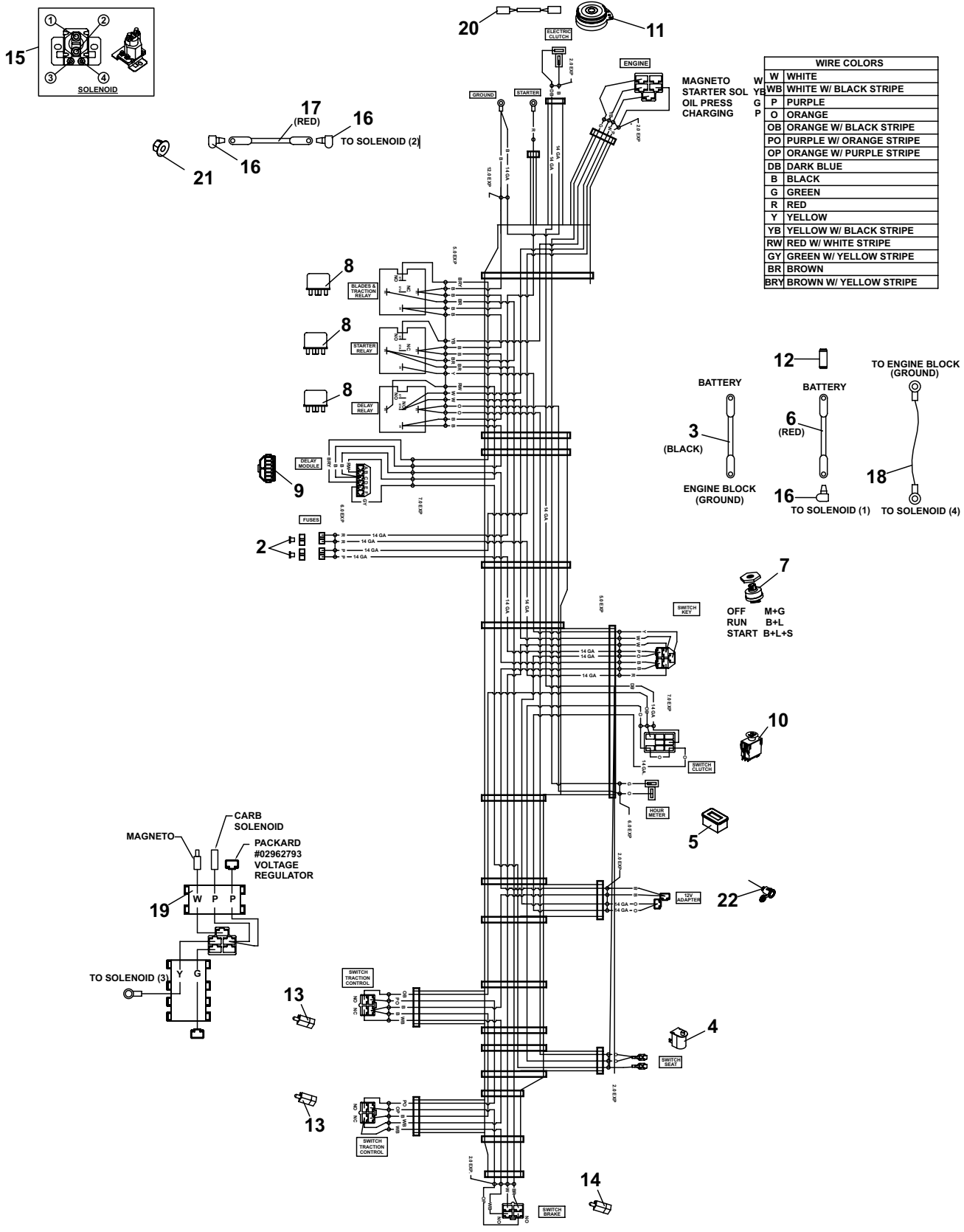

FIGURE 10

ITM	PART NO.	DESCRIPTION	QTY	ITM	PART NO.	DESCRIPTION	QTY
1	4168406	HARNESS-MAIN WIRE	1				
2	148082-20	FUSE 20 AMP	2				
3	30-419	CABLE-BATT 4 GA BLK 29"	1				
4	4124009	SWITCH-SEAT NO	1				
5	4168452	METER-HOUR	1				
6	4168492	CABLE-BATT 4 GA RED 29"	1				
		USED ON 942630 & 942631					
	2722227-02	CABLE-BATTERY 36"	1				
		USED ON 942632,942633, 942634					
7	128010	SWITCH, KEY	1				
8	2722325	RELAY-40AMP SEALED	3				
9	2188154	MODULE-DELAY	1				
10	2721505	SWITCH-PTO	1				
11	4168822	CLUTCH-ELECTRICAL	1				
		USED ON 942630, 942631, 942632					
	4171141	CLUTCH-ELECTRIC	1				
		USED ON 942633 & 942634					
12	112386	BOOT BAT TERM POS	1				
13	108208	SWITCH DBL POLE	2				
14	2188156	SWITCH-NONO DBL POLE	1				
15	38665	SOLENOID	1				
		USED ON 942630 & 942631					
16	2308095	COVER-TERMINAL					
		QTY 3 ON 942630 & 942631					
		QTY 1 ON 942632, 942633, 942634					
17	108061-04	CABLE-BATTERY 20 RED	1				
		USED ON 942630 & 942631					
18	2188225	WIRE-GROUND	1				
		USED ON 942630 & 942631					
19	2188224	HARNESS-JUMPER	1				
		USED ON 942630 & 942631					
	4164496	HARNESS-JUMPER					
		USED ON 942632, 942633, 942634					
20	2720949	ASSY-CLUTCH WIRE	1				
21	64141-2	NUT-WLF 1/4-20	1				
		USED ON 942630 & 942631					
22	4142266	CONNECTOR 12V RECEPT	1				
23*	56-081-36	SLEEVING, ID 0.77 NYLON 2'	1				

* NOT ILLUSTRATED

FIGURE 11

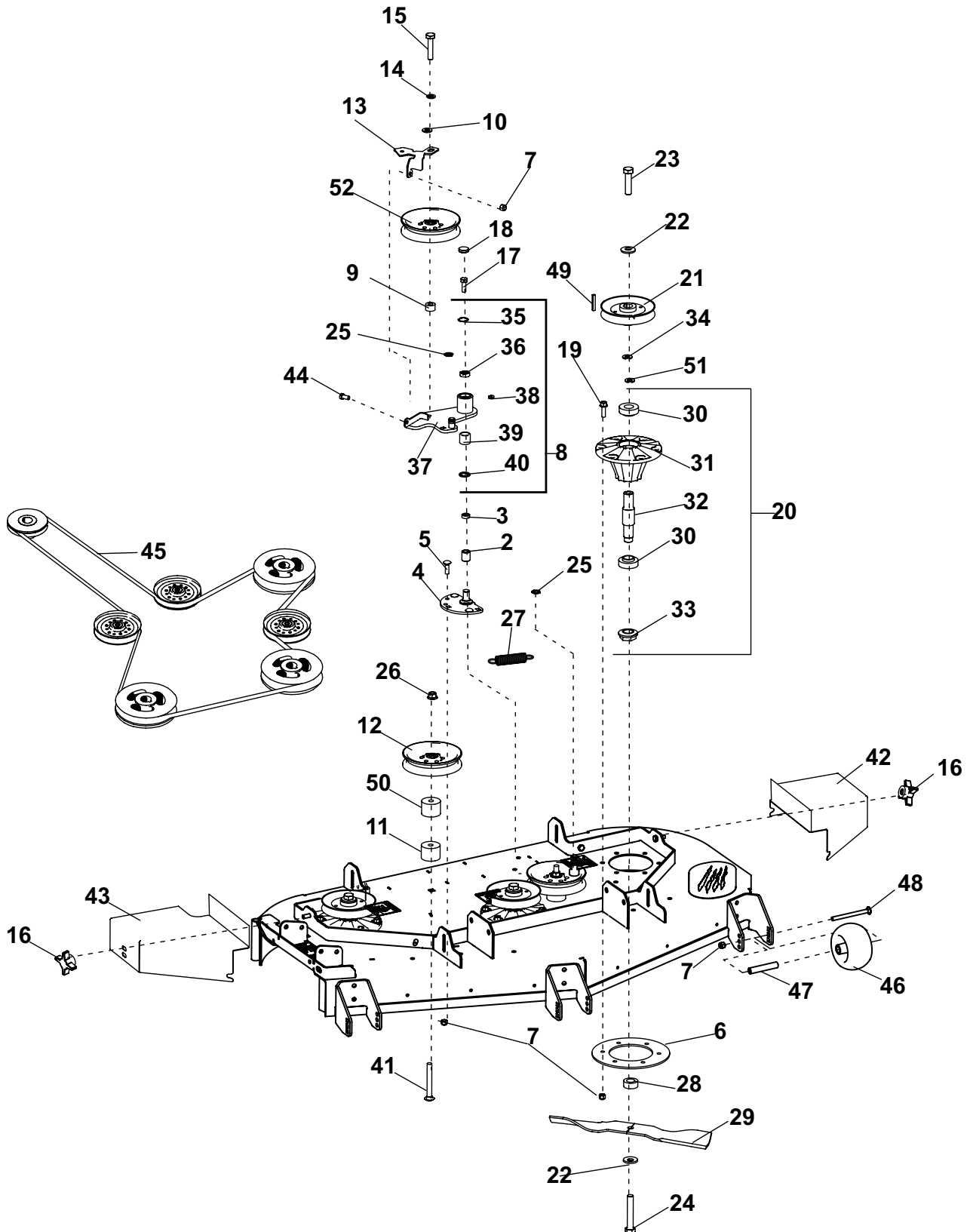

FIGURE 11

ITM	PART NO.	DESCRIPTION	QTY	ITM	PART NO.	DESCRIPTION	QTY
1	4175541	S-48 DECK W/ LABELS	1	41	64018-21	BLT-CRG 1/2-13X4	2
2	4163155	INNER RING	1	42	4173223.7	COVER-BELT 48 LH	1
3	4163014	SPACER	1	43	4173222.7	COVER-BELT 48 RH	1
4	4170021.7	WLDMT-IDLER PIN	1	44	64123-15	BLT-HEX 3/8-16X3/4	1
5	64018-44	BLT-CRG 3/8-16X1 SN	3	45	4169566	BELT-DECK, 48"	1
6	4171609.7	RING-SPINDLE	3	46	2721512	ROLLER-5 X2.75 CENTERED	3
7	64229-03	NUT-NYLON LOCK 3/8-16	25	47	2720685	SPACER-ROLLER	3
8	4175497	ASSY-IDLER ARM (INCLUDES ITEMS 35-40)	1	48	64018-30	BLT-CRG 3/18-16 X 4-1/2	3
9	4163802-02	SPACER-1.0 X .516 X 1 3/16	1	49	64164-13	KEY 1/4 X 2 SQ	3
10	64163-67	WASHER-2 X .516 X 1.07	1	50	4152578-01	SPACER-2 X .516 X .938	2
11	4152578-02	SPACER-2.0 X .516 X 1.45	2	51	64163-68	WSHR-1.015X1.5X9GA	3
12	4176836	PULLEY, IDLER 5.50	2	52	4176803	PULLEY-IDLER, 5.50	1
13	4175480.7	GUIDE-BELT IDLER	1				
14	64006-05	LOCKWSHR-1/2 HELICAL	1				
15	64123-337	BLT-HEX 1/2-20X3-1/4	1				
16	38524	KNOB-4 PRONG 3/8-16	2				
17	64270-02	BOLT-HEX M10-1.5X30	1				
18	4128002	END CAP	1				
19	64262-012	BLT-FLG HD 3/8-16 X 1-1/4	18				
20	4171231	ASSY-CUTTERDECK SPINDLE 3 (INCLUDES ITEMS 30-33)	3				
21	4168381	5.30 EOD DP GRV	3				
22	64209-03	SPRING WASHER.67 ID	6				
23	64123-108	BLT-HEX 5/8-18X2-1/2	3				
24	64123-187	BLT-HEX 5/8-18 X 3 3/4	3				
25	64144-36	SNAP RING .625	2				
26	64268-05	NUT-FL NYLON LOCK 1/2-13	2				
27	2308133	SPRING-EXTENSION	1				
28	4118314	SPACER-BLADE	3				
29	112111-01	BLADE 16.25 OFFST HLFT	3				
30	4167554-01	BEARING-SPINDLE SEALED	6				
31	4164948	HOUSING-SPINDLE 6 HOLE	3				
32	2183070-02	SHAFT-SPINDLE LONG	3				
33	38315	NUT-SPINDLE	3				
34	64163-64	WSHR 1.015X1.500X14GA	3				
35	64144-40	SNAP RING	1				
36	4128004	BEARING	1				
37	4175489.7	WLDMT-IDLER ARM	1				
38	85010N	ZERK-1/4-28	1				
39	548138	BRG NDL.88 1.12 1.00 OPEN END	1				
40	521438	GREASE SEAL	1				

FIGURE 12

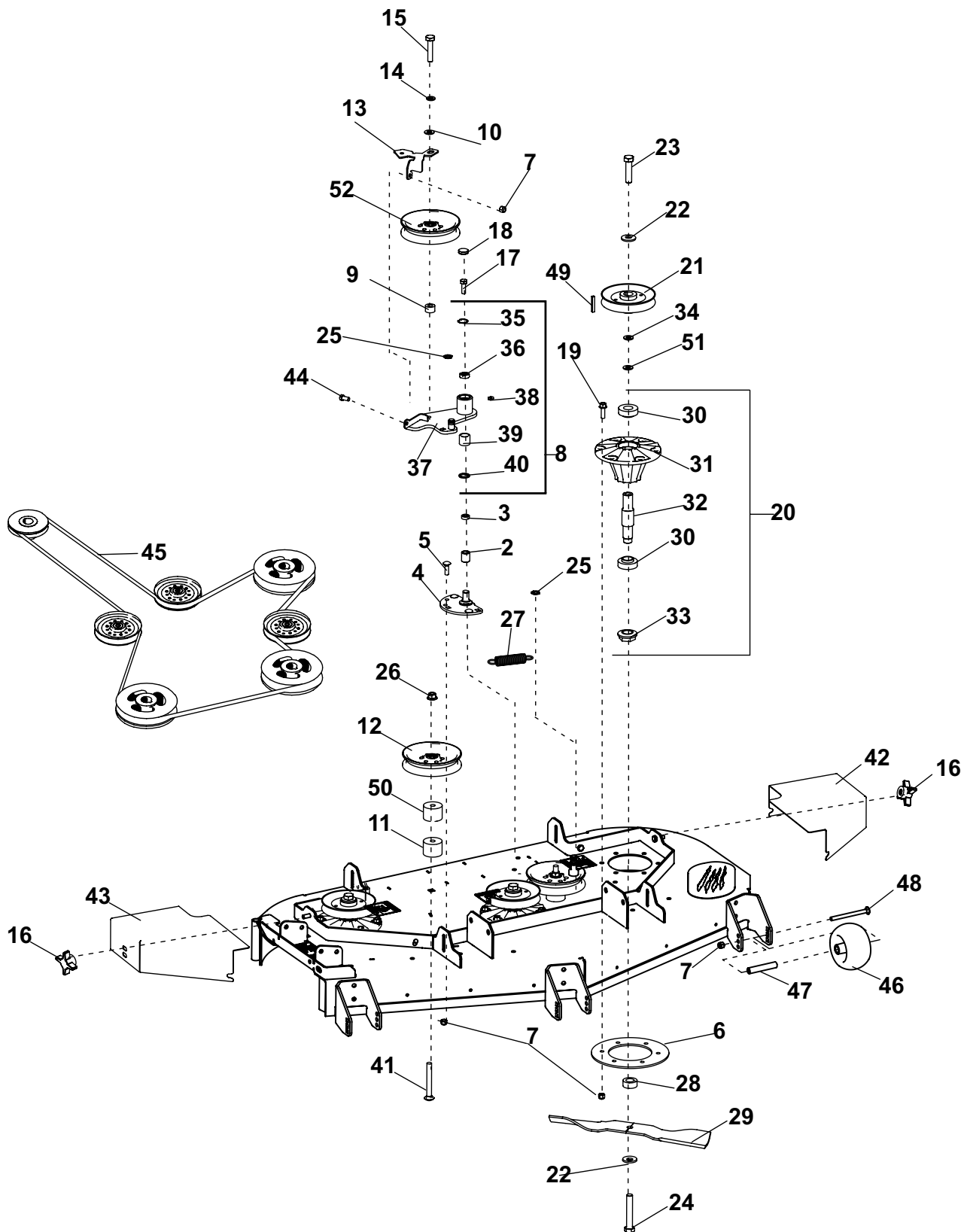

FIGURE 12

ITM	PART NO.	DESCRIPTION	QTY	ITM	PART NO.	DESCRIPTION	QTY
1	4175542	S-52 DECK W/ LABELS	1	44	64123-15	BLT-HEX 3/8-16X3/4	1
2	4163155	INNER RING	1	45	4169640	BELT-DECK, 52"	1
3	4163014	SPACER	1	46	2721512	ROLLER-5 X2.75 CENTERED	3
4	4170021.7	WLDMT-IDLER PIN	1	47	2720685	SPACER-ROLLER	3
5	64018-44	BLT-CRG 3/8-16X1 SN	3	48	64018-30	BLT-CRG 3/18-16 X 4-1/2	3
6	4171609.7	RING-SPINDLE	3	49	64164-13	KEY 1/4 X 2 SQ	3
7	64229-03	NUT-NYLON LOCK 3/8-16	25	50	4152578-01	SPACER-2 X .516 X .938	2
8	4175497	ASSY-IDLER ARM	1	51	64163-68	WSHR-1.015X1.5X9GA	3
		(INCLUDES ITEMS 35-40)		52	4176803	PULLEY, IDLER 5.50	1
9	4163802-02	SPACER-1.0 X .516 X 1 3/16	1				
10	64163-67	WASHER-2 X .516 X 1.07	1				
11	4152578-02	SPACER-2.0 X .516 X 1.45	2				
12	4176836	PULLEY, IDLER 5.50	2				
13	4175480.7	GUIDE-BELT IDLER	1				
14	64006-05	LOCKWSHR-1/2 HELICAL	1				
15	64123-337	BLT-HEX 1/2-20X3-1/4	1				
16	38524	KNOB-4 PRONG 3/8-16	2				
17	64270-02	BOLT-HEX M10-1.5X30	1				
18	4128002	END CAP	1				
19	64262-012	BLT-FLG HD 3/8-16 X 1-1/4	18				
20	4171231	ASSY-CUTTERDECK SPINDLE	3				
		(INCLUDES ITEMS 30-33)					
21	4168381	SHEAVE- 5.30 EOD DP GRV	3				
22	64209-03	SPRING WASHER.67 ID	6				
23	64123-108	BLT-HEX 5/8-18X2-1/2	3				
24	64123-187	BLT-HEX 5/8-18 X 3 3/4	3				
25	64144-36	SNAP RING .625	2				
26	64268-05	NUT-FL NYLON LOCK 1/2-13	2				
27	2308133	SPRING-EXTENSION	1				
28	4118314	SPACER-BLADE	3				
29	112111-02	BLADE 18.00 OFFST HLFT	3				
	112111-02-LE	BLADE 18.00 LAZER EDGE (OPT)					
30	4167554-01	BEARING-SPINDLE SEALED	6				
31	4164948	HOUSING-SPINDLE 6 HOLE	3				
32	2183070-02	SHAFT-SPINDLE LONG	3				
33	38315	NUT-SPINDLE	3				
34	64163-64	WSHR 1.015X1.500X14GA	3				
35	64144-40	SNAP RING	1				
36	4128004	BEARING	1				
37	4175489.7	WLDMT-IDLER ARM	1				
38	85010N	ZERK-1/4-28	1				
39	548138	BRGNDL.88 1.12 1.00 OPEN END	1				
40	521438	GREASE SEAL	1				
41	64018-21	BLT-CRG 1/2-13X4	2				
42	4169305.7	COVER-BELT 52 LH	1				
43	4169304.7	COVER-BELT 52 RH	1				

FIGURE 13

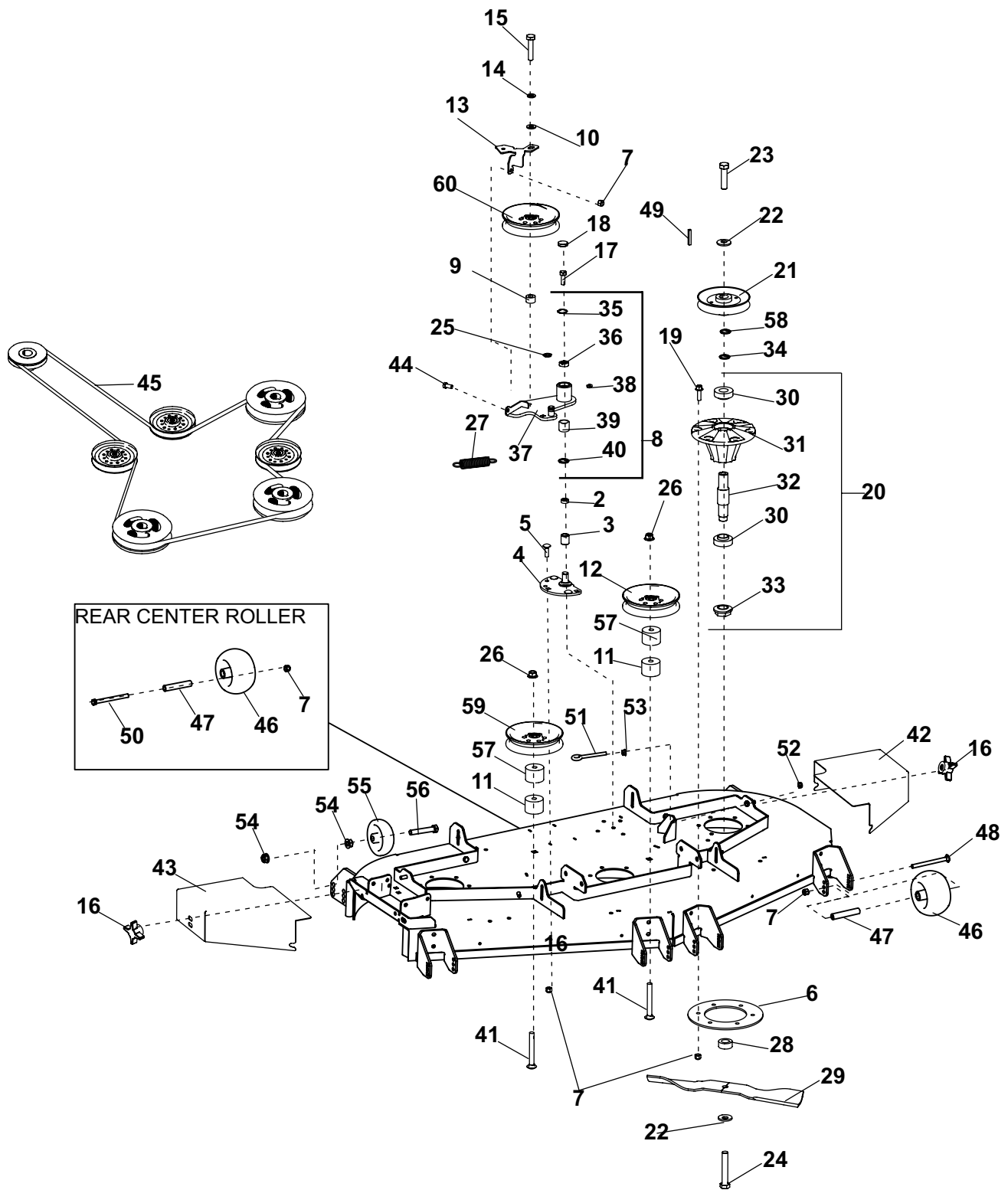

FIGURE 13

ITM	PART NO.	DESCRIPTION	QTY	ITM	PART NO.	DESCRIPTION	QTY
1	4175543	S-61 DECK W/ LABELS	1	44	64123-15	BLT-HEX 3/8-16X3/4	1
2	4163155	INNER RING	1	45	4163569	BELT-DECK, 61"	1
3	4163014	SPACER	1	46	2721512	ROLLER-5 X2.75 CENTERED	5
4	4170021.7	WINTERTIDES PIN	1	47	2720685	SPACER-ROLLER	5
5	64018-44	BLT-CRG 3/8-16X1 SN	3	48	64018-30	BLT-CRG 3/18-16 X 4-1/2	4
6	4171609.7	RING-SPINDLE	3	49	64164-13	KEY 1/4 X 2 SQ	3
7	64229-03	NUT-NYLON LOCK 3/8-16	27	50	64123-217	BLT-HEX 3/8-16X4-1/4	1
8	4175497	ASSY-IDLER ARM	1	51	64158-08	EYE BOLT 5/16-18 X 2.5	1
		(INCLUDES ITEMS 35-40)		52	64229-02	NUT-NYLON LOCK 5/16-18	1
9	4163802-02	SPACER-1.0 X .516 X 1 3/16	1	53	64141-6	NUT-WLF 5/16-18	1
10	64163-67	WASHER-.531 x 2.00 x .125	1	54	64141-13	NUT-WLF, 1/2-13	4
11	4152578-02	SPACER-2.0 X .516 X .938	2	55	4163332	ROLLER-ANTI SCALP	2
12	4176836	PULLEY, IDLER 5.50	2	56	64123-31	BLT-HEX 1/2-13	2
13	4175480.7	GUIDE-BELT IDLER	1	57	4152578-01	SPACER-2.0 X .516 X .938	2
14	64006-05	LOCKWSHR-1/2 HELICAL	1	58	64163-64	WSHR 1.015X1.500X14GA	3
15	64123-337	BLT-HEX 1/2-20X3-1/4	1	59	4165953	PULLEY-IDLER 6.0	1
16	38524	KNOB-4 PRONG 3/8-16	2	60	4176803	PULLEY-IDLER 5.50	1
17	64270-02	BOLT-HEXM10-1.5X30	1				
18	4128002	END CAP	1				
19	64262-012	BLT-FLG HD 3/8-16 X 1-1/4	18				
20	4171231	ASSY-CUTTERDECK SPINDLE	3				
		(INCLUDES ITEMS 30-33)					
21	4167735	PULLEY-SPINDLE, 61IN	3				
22	64209-03	SPRING WASHER.67 ID	6				
23	64123-108	BLT-HEX 5/8-18X2-1/2	3				
24	64123-187	BLT-HEX 5/8-18 X 3 3/4	3				
25	64144-36	SNAP RING .625	1				
26	64268-05	NUT-FL NYLON LOCK 1/2-13	2				
27	4163586	SPRING-EXTENSION	1				
28	4118314	SPACER-BLADE	3				
29	112111-03	BLADE 21.00 OFFST HLFT	3				
	112111-03-LE	BLADE 21.00 LAZER EDGE (OPT)					
30	4167554-01	BEARING-SPINDLE SEALED	6				
31	4164948	HOUSING-SPINDLE 6 HOLE	3				
32	2183070-02	SHAFT-SPINDLE LONG	3				
33	38315	NUT-SPINDLE	3				
34	64163-68	WSHR-1.015X1.5X9GA	3				
35	64144-40	SNAP RING	1				
36	4128004	BEARING	1				
37	4175489.7	WLDMT-IDLER ARM	1				
38	85010N	ZERK-1/4-28	1				
39	548138	BRGNDL88 1.12 1.00 OPEN END	1				
40	521438	GREASE SEAL	1				
41	64018-21	BLT-CRG 1/2-13X4	2				
42	4169309.7	COVER-BELT 61 LH	1				
43	4169308.7	COVER-BELT 61 RH	1				

CHUTE, BAFFLES, EDGES, & DECK LINKS

XRZ PRO RS

FIGURE 14

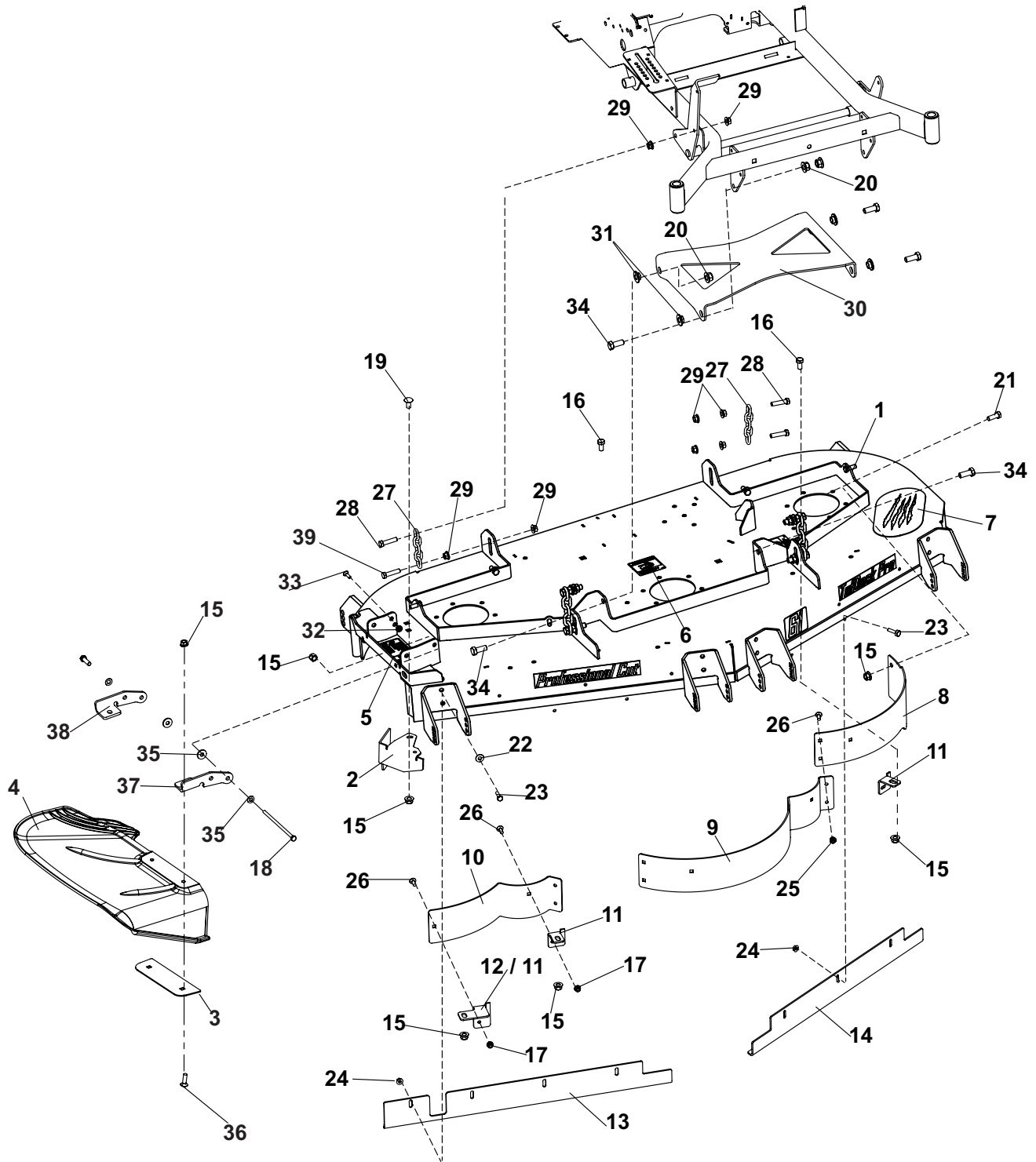

XRZ PRO RS CHUTE, BAFFLES, EDGES, & DECK LINKS

FIGURE 14

ITM	PART NO.	DESCRIPTION	QTY	ITM	PART NO.	DESCRIPTION	QTY
1	4175541	S-48" DECK W/LABELS	1	15	64268-03	NUT-FL NYLON LOCK 3/8-16	10
	4175542	S-52" DECK W/LABELS		16	64123-15	BLT-HEX 3/8-16X3/4	3
	4175543	S-61" DECK W/LABELS		17	64268-01	NUT-FL NYLON LOCK 1/4-2	3
2	4173420.2	BAFFLE-DISCHARGE, 48"&52"	1	18	64123-16	BLT-HEX 3/8-16X1-1/4	2
	4171432.2	BAFFLE-DISCHARGE, 61"		19	64018-23	BLT-CRG 3/8-16X3/4 SHRTNK	2
3	4173063.7	PLATE-CHUTE	1	20	64268-05	NUT-FL NYLON LOCK 1/2-13	2
4	4172328	CHUTE-PLASTIC	1	21	64123-50	BLT-HEX 3/8-16X1	1
5	4164269	LABEL-WARNING THROWN	1	22	64163-55	WSHR .328X.75X14 GA	1
6	2000577	LABEL WARNING	3	23	64123-114	BLT-HEX 1/4-20X1	7
7	4168522	MAT-CLAW MARKS	1	24	64141-2	NUT-WLF 1/4-20	7
8	4165971.7	BAFFLE-FRONT LH 48"	1	25	64229-01	LOCKNUT-1/4-20 NYLON	4
	4165965.7	BAFFLE-FRONT LH 52"		26	64018-2	BLT-CRG 1/4-20X3/4	7
	4165968.7	BAFFLE-FRONT LH 61"		27	2188127	CHAIN-6.35 (.250) 5 LINKS	4
9	4165972.7	BAFFLE FRONT CENTER, 48"	1	28	64205-060	BLT-METRIC M12-1.75X50	4
	4165966.7	BAFFLE-FRONT CENTER, 52"		29	64246-04	NUT-WHIZ M12-1.75	16
	4168642.7	BAFFLE-FRONT CENTER, 61"		30	4175098.7	BRKT-PULLARM	1
10	4168527.7	BAFFLE-FRONT, RH 48"	1	31	4175019	SPACER-PULL ARM	4
	4168516.7	BAFFLE-FRONT, RH 52"		32	64229-03	NUT-NYLON LOCK 3/8-16	1
	4171792.7	BAFFLE-FRONT, RH 61"		33	64189-28	BLT-HEX SOC, 3/8-16 X 3/4	1
11	4168514.2	BRKT-BAFFLE MNTG, 48" &52" (942630 QTY 3, 942631 QTY 2)		34	64123-39	BLT-HEX 1/2-13X1-1/4	4
	4168523.2	BRKT-BAFFLE MNTG 61"	2	35	4169895	WSHR-FRICTION, UHMW	2
12	4168515.2	BRKT-BAFFLE MNTG, RH 52"	1	36	64018-49	BLT-CRG 3/8-16X1-1/2	2
	4168487.2	BRKT-BAFFLE MNTG, RH 61"		37	4177411.7	BRKT-CHUTE, FRONT	1
13	4166929.2	EDGE-LEADING RH 48"	1	38	4177410.7	BRKT-CHUTE, REAR	1
	4166478.2	EDGE-LEADING RH 52"		39	64205-029	NUT-HEX 5/16-24	4
	4166480.2	EDGE-LEADING RH 61"					
14	4166930.2	EDGE-LEADING LH 48"	1				
	4166479.2	EDGE-LEADING LH 52"					
	4166481.2	EDGE-LEADING LH 61"					

FIGURE 15

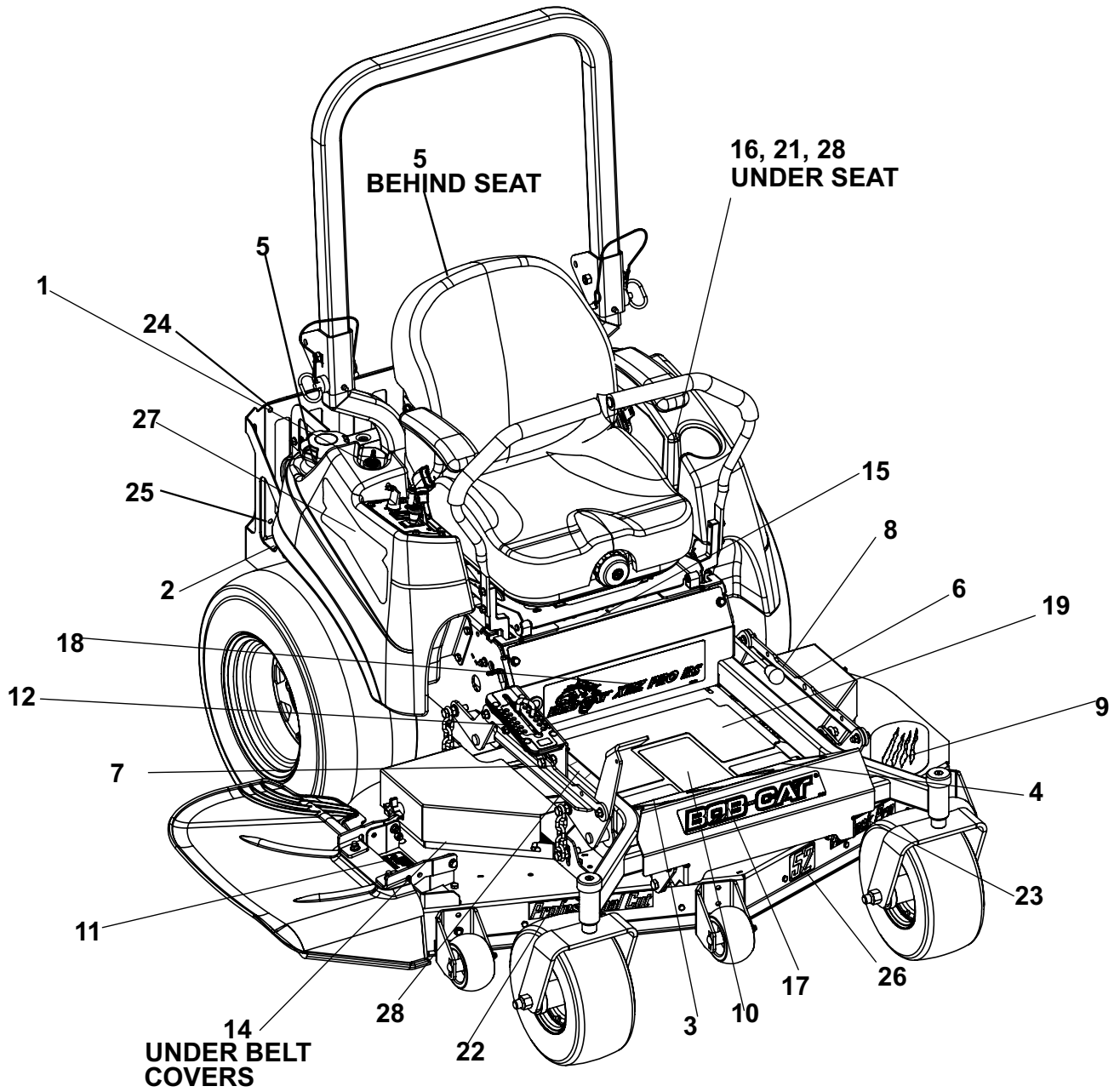
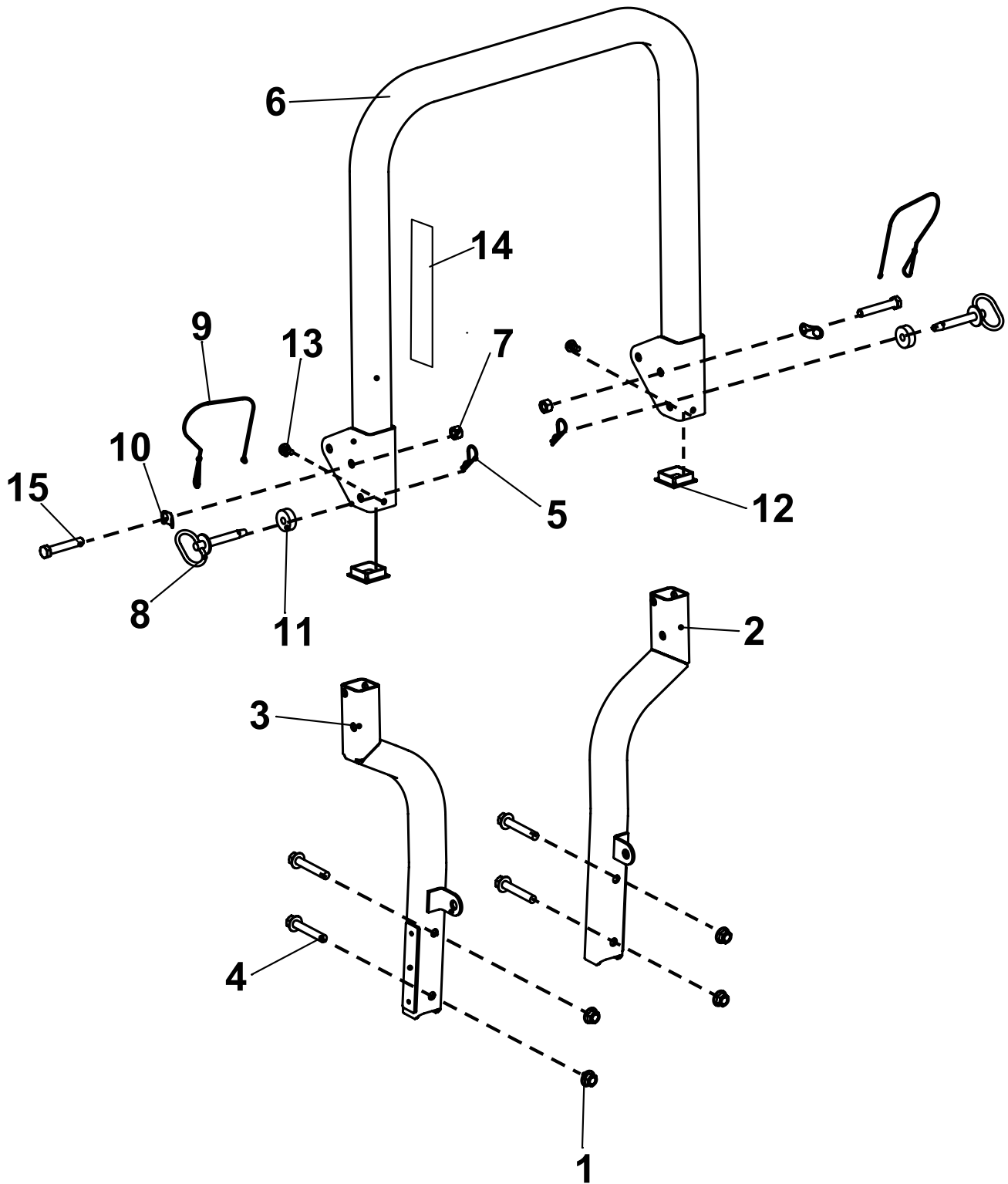

FIGURE 15

ITM	PART NO.	DESCRIPTION	QTY	ITM	PART NO.	DESCRIPTION	QTY
1	4168477	LABEL-CONTROL PANEL	1				
2	2000570	LABEL-WARN FUEL PICT.	2				
3	4167087	MAT-FOOTPLT UPPER RH	1				
4	4167088	MAT-FOOTPLT UPPER LH	1				
5	2000590	LABEL-WARN BATTERY	1				
6	4165616	LABEL-LH TRACTION	1				
7	4165615	LABEL-RH TRACTION	1				
8	4167203	LABEL-PARKING BRAKE	1				
9	4168522	LABEL-CLAW MARKS	1				
10	4165610	LABEL-WARNING	1				
11	4164269	LABEL-DANGER/WARNING	1				
12	4169639	LABEL-HOC	1				
13	4147617	LABEL FUEL TANK VALVE	1				
14	2000577	LABEL, WARNING	3				
15	4168517	LABEL-MANUAL LOCATION	1				
16	4133980	LABEL-MAINTENANCE	1				
17	4164406	LABEL-BOB-CAT	1				
18	4175355	LABEL-XRZ PRO RS	1				
19	4165931	MAT-FOOTPLT LOWER	1				
20	4171663	LABEL BELT DIAGRAM	1				
21	2000735	LABEL-OPER MAN	1				
22	4168615	LABEL-PROFESSIONAL CUT	1				
23	4171900	LABEL-TUFDECK PRO	1				
24	4164946	LABEL-BOBCAT	1				
25	4116761	LABEL-USA	1				
26	4162914	LABEL-DECK SIZE 48"	1				
	4162915	LABEL-DECK SIZE 52"					
	4162916	LABEL-DECK SIZE 61"					
27	4176620	LABEL-TANK, FUEL	2				
28	4177522	LABEL-DECK LIFT	1				

FIGURE 16



ITM	PART NO.	DESCRIPTION	QTY	ITM	PART NO.	DESCRIPTION	QTY
1	64268-05	NUT-FL NYLON LOCK 1/2-13	4				
2	4175326.2	WLDMT-LOWER ROPS, LH	1				
3	4175327.2	WLDMT-LOWER ROPS, RH	2				
4	64262-033	BLT-FLG HD 1/2-13 X 3 GR8	4				
5	64168-1	COTTER-HAIRPIN .120 x 2-3/8	2				
6	4167954.2	KIT-UPPER LOOP KIT INCLUDES ITEMS 5, 7-15	1				
7	64151-7	NUT-HEX 1/2-13 CTR LOCK	2				
8	4162879	PIN-HITCH 1/2	2				
9	4162880	LANYARD-NYLON	2				
10	4160348	WASHER-FORMED RETAINER	2				
11	4162878	WASHER EPDM 1/2	2				
12	4160344	PLUG 2 X 1/8 WALL SQ TUBE	2				
13	4160343	BUMPER-RUBBER	2				
14	4160347	LABEL-WARNING ROPS	1				
15	64123-31	BLT-HEX 1/2-13X3	2				

SCHILLER GROUNDS CARE, INC.
ONE BOB-CAT LANE
P.O. BOX 469
JOHNSON CREEK, WI 53038
920-699-2000
www.schillergc.com

