



# ***BOB-CAT***<sup>®</sup>

## **SETUP, PARTS & MAINTENANCE MANUAL PREDATOR-PRO SERIES**

---

### **MODELS:**

**942240E PREDATOR PRO 26HP GEN W/52 SD**  
**942241E PREDATOR PRO 33HP GEN W/61 SD**  
**942242E PREDATOR PRO 33HP GEN W/72 SD**  
**942245E PREDATOR PRO 26HP KAW LC W/61SD**



*WARNING: If incorrectly used this machine can cause severe injury. Those who use and maintain this machine should be trained in its proper use, warned of its dangers and should read the entire manual before attempting to set up, operate, adjust or service the machine.*

**4158126 REV A**

---

**Operation & Safety Manual: 4158190**

**CGC**  
*Commercial Grounds Care, Inc.*

**CALIFORNIA  
Proposition 65 Warning**

Diesel engine exhaust and some of its constituents are known to the State of California to cause cancer, birth defects and other reproductive harm.

 **WARNING**

The engine exhaust from this product contains chemicals known to the State of California to cause cancer, birth defects or other reproductive harm.

**Californie Proposition 65  
Avertissement**

Les échappements des moteurs diesel et certains de leurs composés sont reconnus par l'Etat de Californie pour être cancérigènes, provoquer des défauts congénitaux et d'autres dangers en matière de reproduction.

 **AVERTISSEMENT**

L'émission du moteur de ce matériel contient des produits chimiques que l'Etat de Californie considère être cancérigènes, provoquer des défauts congénitaux et d'autres dangers en matière de reproduction.

**California Advertencia  
de la Proposicion 65**

El estado de California hace saber que los gases de escape de los motores diesel y algunos de sus componentes producen cáncer, defectos de nacimiento y otros daños en el proceso de reproducción humana.

 **ADVERTENCIA**

El estado de California hace saber que los gases de escape de este producto contienen productos químicos que producen cáncer, defectos de nacimiento y otros daños en el proceso de reproducción humana.

**CALIFORNIA  
Proposition 65 Warning**

Battery posts, terminals, wiring insulation, and related accessories contain lead and lead compounds, chemicals known to the State of California to cause cancer and birth defects or other reproductive harm.  
**WASH HANDS AFTER HANDLING.**

# PREDATOR-PRO SERIES

## IMPORTANT MESSAGE

Thank you for purchasing this CGC, Inc. product. You have purchased a world class mowing product, one of the best designed and built anywhere.

This machine comes with an Operation and Safety Manual and a separate Setup, Parts and Maintenance Manual. The useful life and good service you receive from this machine depends to a large extent on how well you read and understand these manuals. Treat your machine properly, lubricate and adjust it as instructed, and it will give you many years of reliable service.

Your safe use of this CGC, Inc. product is one of our prime design objectives. Many safety features are built in, but we also rely on your good sense and care to achieve accident-free operation. For best protection, study the manuals thoroughly. Learn the proper operation of all controls. Observe all safety precautions. Follow all instructions and warnings completely. Do not remove or defeat any safety features. Make sure those who operate this machine are as well informed and careful in its use as you are.

See a CGC, Inc. dealer for any service or parts needed. CGC, Inc. service ensures that you continue to receive the best results possible from CGC, Inc. products. You can trust CGC, Inc. replacement parts because they are manufactured with the same high precision and quality as the original parts.

CGC, Inc. designs and builds its equipment to serve many years in a safe and productive manner. For longest life, use this machine only as directed in the manuals, keep it in good repair and follow safety warnings and instructions. You'll always be glad you did.

**Commercial Grounds Care, Inc.**  
**One Bob Cat Lane**  
**Johnson Creek, WI 53038-0469**

TABLE OF CONTENTS	FIGURES	PAGE
SAFETY .....		2
ASSEMBLY AND SETUP .....		3-5
MAINTENANCE CHART .....		6
MAINTENANCE RECORD .....		7
MAINTENANCE .....		8-13
ADJUSTMENTS .....		14-17
BELT REPLACEMENT .....		18, 19
SPECIFICATIONS .....		20-22
PART SECTION .....		23
UPPER ENGINE DECK ASSY .....	FIGURE 1 .....	24, 25
LOWER ENGINE DECK ASSY/CLUTCH .....	FIGURE 2 .....	26, 27
BUMPER .....	FIGURE 3 .....	28, 29
FUEL TANKS/CONTROL PANEL .....	FIGURE 4 .....	30, 31
BRAKES/REAR WHEEL .....	FIGURE 5 .....	32, 33
OIL COOLER .....	FIGURE 6 .....	34, 35
HYDRAULICS .....	FIGURE 7 .....	36, 37
HYDROGEAR PUMP .....	FIGURE 8 .....	38, 39
GENERAC WIRE HARNESS .....	FIGURE 9 .....	40, 41
KAWASAKI WIRE HARNESS LC .....	FIGURE 10 .....	42, 43
SEAT ASSEMBLY & ROPS .....	FIGURE 11 .....	44, 45
STEERING/DECK LIFT .....	FIGURE 12 .....	46, 47
CRADLE ASSEMBLY .....	FIGURE 13 .....	48, 49
CRADLE & CASTER ASSEMBLY .....	FIGURE 14 .....	50, 51
52" SIDE DISCHARGE .....	FIGURE 15 .....	52, 53
61" SIDE DISCHARGE .....	FIGURE 16 .....	54, 55
72" SIDE DISCHARGE .....	FIGURE 17 .....	56, 57
BELTS-CUTTERDECK .....	FIGURE 18 .....	58, 59
DECALS-POWER UNIT .....	FIGURE 19 .....	60, 61
DECALS-CUTTERDECKS .....	FIGURE 20 .....	62, 63
WIRING SCHEMATIC KAW LC .....	FIGURE 21 .....	64

**NOTICE !!!**

Unauthorized modifications may present **extreme** safety hazards to operators and bystanders and could also result in product damage.

Commercial Grounds Care, Inc. strongly warns against, rejects and disclaims any modifications, add-on accessories or product alterations that are not designed, developed, tested and approved by CGC, Inc. Engineering Department. Any CGC, Inc. product that is altered, modified or changed in any manner not specifically authorized after original manufacture-including the addition of "after-market" accessories or component parts not specifically approved by CGC, Inc.-will result in the CGC, Inc. Warranty being voided.

Any and all liability for personal injury and/or property damage caused by any unauthorized modifications, add-on accessories or products not approved by CGC, Inc. will be considered the responsibility of the individual(s) or company designing and/or making such changes. CGC, Inc. will vigorously pursue full indemnification and costs from any party responsible for such unauthorized post-manufacture modifications and/or accessories should personal injury and/or property damage result.



This symbol means:  
**ATTENTION!**  
**BECOME ALERT!**

Your safety and the safety of others is involved.

**Signal word definitions:**

The signal words below are used to identify levels of hazard seriousness. These words appear in this manual and on the safety labels attached to CGC, Inc. machines. For your safety and the safety of others, read and follow the information given with these signal words and/or the symbol shown above.

**⚠ DANGER**

**DANGER** indicates an imminently hazardous situation which, if not avoided, **WILL** result in death or serious injury.

**⚠ WARNING**

**WARNING** indicates a potentially hazardous situation which, if not avoided, **COULD** result in death or serious injury.

**⚠ CAUTION**

**CAUTION** indicates a potentially hazardous situation which, if not avoided, **MAY** result in minor or moderate injury. It may also be used to alert against unsafe practices or property damage.

**CAUTION**

**CAUTION** used without the safety alert symbol indicates a potentially hazardous situation which, if not avoided, **MAY** result in property damage

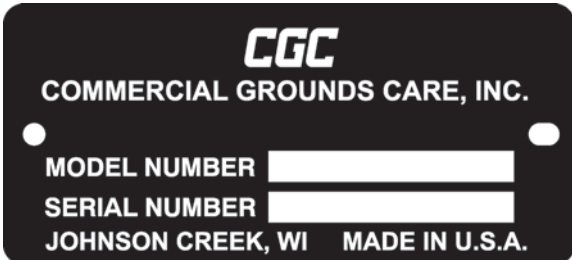

**MODEL NUMBER:** This number appears on sales literature, technical manuals and price lists.

**SERIAL NUMBER:** This number appears only on your mower. It contains the model number followed consecutively by the serial number. Use this number when ordering parts or seeking warranty information.

### TOOLS REQUIRED FOR ASSEMBLY

- Wrecking bar
- Claw hammer
- Ratchets: 3/8"
- Sockets: 3/8", 1/2", 17 mm
- Wrenches: 13 mm, 15 mm, 17 mm, 18 mm, 1-1/16", 1-1/8"
- Straight edge
- Tire pressure gauge
- Blocks (for deck leveling)

**NOTE:** All references below to the "right" or "left" are with respect to an operator at the controls.

### 1. UNCRATE UNIT

- Discard packing materials. Remove and discard shipping brackets. Tighten caster wheel axle bolts against caster axle spanner bushings.

### 2. INSTALL SEAT

- Install bushings **J** in seat plate **Z**.
- Install seat assembly onto the unit using (2) pins **X** and (2) E-clips **Y**.
- Secure seat wire **W** on the bottom of the seat plate with clip **C** and a 1/4-20 X 3/8 thread forming screw.
- Connect the tractor harness to the seat wire.

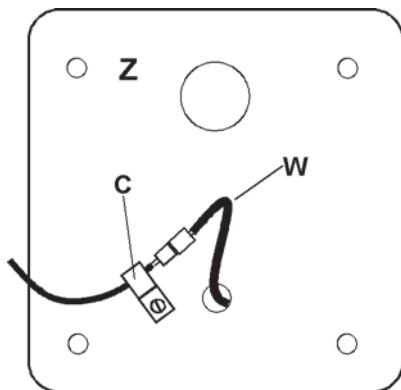

Bottom of seat plate **Z** showing clip **C**

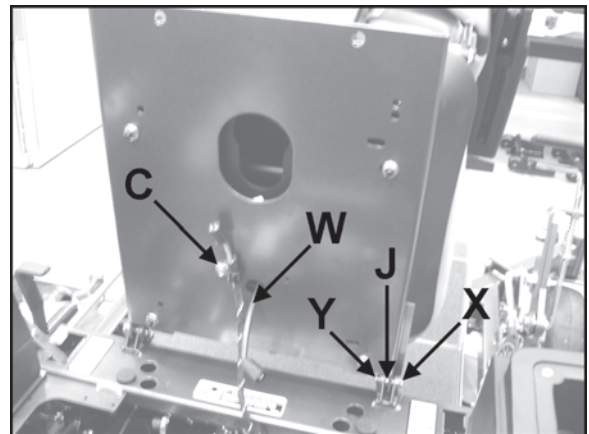

- Set tire pressures to 14 lbs/in<sup>2</sup> (1.0 kg/cm<sup>2</sup>). Tires are overinflated for shipping.

## 4. TRACTION LEVERS

- Loosen bolt **A** and remove bolt **B**.
- Rotate traction lever **D** into position and secure with bolts **A** and **B**. Repeat for the other lever.
- Tighten all fasteners.
- Sit on the machine. Levers may be adjusted in bracket **C** for a more comfortable reach, or moved to upper set of holes for a better operator fit.

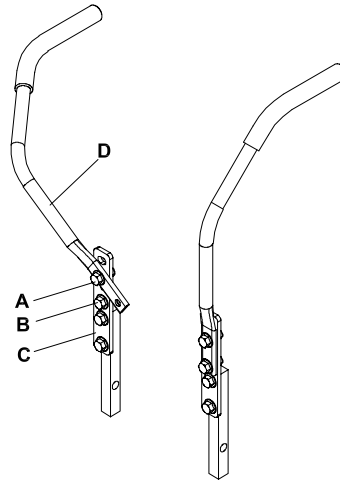

## 5. DECK LEVELING

- Park the machine on a smooth, level surface. Raise the deck to the transport position.
- Lower the deck onto a set of equal height blocks **A** under the rear corners of the deck. Place another set of blocks **B** under the front of the deck so that the deck top is pitched forward 1/8".

**NOTE:** The front and rear of the deck are at different heights.

- Measure the height of the blade cutting edge above the ground. Remove pin **C** and set the height of cut lever **D** to that height.
- Loosen nuts **I** at all four corners of the deck.

**NOTE:** This will relieve tension on chains **H**.

- Loosen the jam nuts **E** on the height of cut clips **F** and adjusting screws **G**. Turn the adjusting screws **G** until the play is taken out of the chains **H** at all four corners. Tighten the jam nuts **E** against the clips **F** and at the adjusting screws **G**. Retighten nuts **I** at this time.

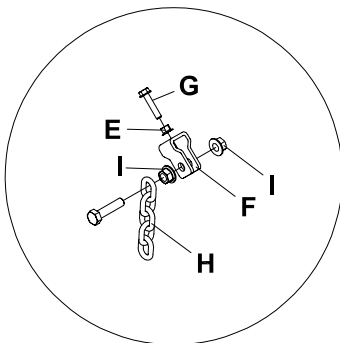
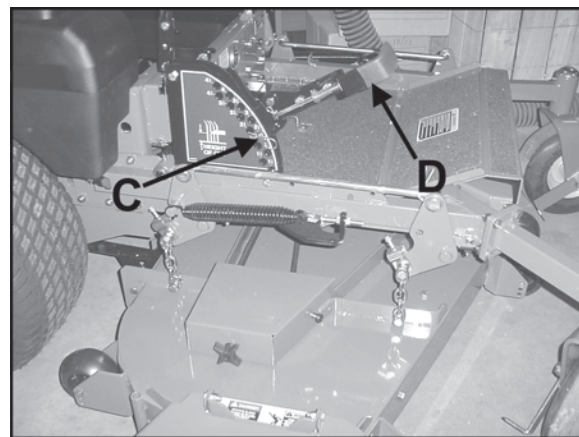
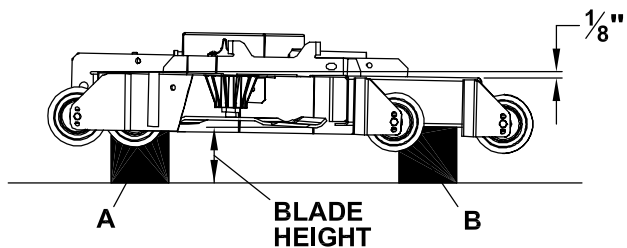

### 6. COUNTERBALANCE SPRINGS

- a) Raise the cutterdeck all the way.
- b) Adjust the spring **A** with nut **B**:
  - 52" cutterdecks to a length of 9-1/8" (232 mm)
  - 61" cutterdecks to a length of 9-9/16" (242 mm)
  - 72" cutterdecks to a length of 10-1/8" (257 mm)The springs may be tightened or loosened from this point according to personal preference.

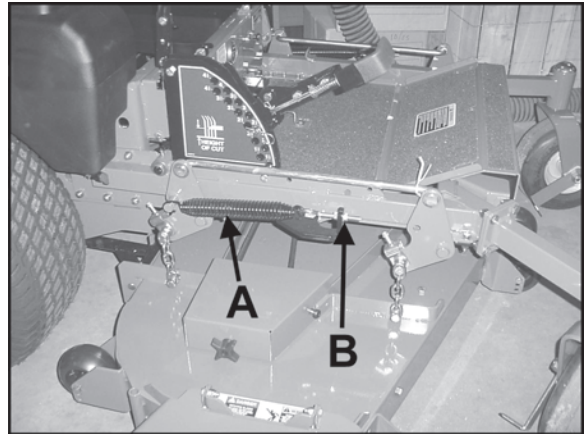

### 7. FINAL PREPARATIONS

- Check the engine and hydraulic oil levels. Top up with the correct oil if necessary. Use 10W30 motor oil for the engine. Use fresh, clean 15W40 or 20W50 motor oil or 15W50 synthetic motor oil for the hydraulic system.
- Remove the battery from the machine. Fill the battery to the bottom of the vent wells with acid and trickle charge for several hours.

**⚠ WARNING** Battery acid is caustic and fumes are explosive and can cause serious injury or death.

Use insulated tools, wear protective glasses or goggles and protective clothing when working with batteries. Read and obey the battery manufacturer's instructions.

Be certain the ignition switch is OFF and the key has been removed before servicing the battery.

- a) Verify battery polarity before connecting or disconnecting the battery cables.
  - b) When installing the battery, always assemble the RED, positive ( + ) battery cable first and the ground, BLACK, negative ( - ) cable last.
  - c) Tighten cables securely to battery terminals and apply a light coat of silicone dielectric grease to terminals and cable ends to prevent corrosion. Keep terminal covers in place.
- Read Operation and Safety Manual before starting.
  - Run engine at full RPM for 5 minutes before engaging blades to allow the engine to be fully lubricated before load is applied.
  - Check the hydrostat neutral adjustment. Neutral is set at the factory but may require readjustment if air trapped during the initial oil fill has worked out of the system. See adjustments section later in this manual.
  - Do not use the machine without an approved grass collector, the grass discharge chute or mulching plates correctly fitted.



# MAINTENANCE CHART

# PREDATOR-PRO SERIES

MAINTENANCE OPERATION	Maintenance is an ongoing job. These intervals are maximum times between maintenance operations. Perform more often under severe conditions.						
	FIRST 5 HOURS	DAILY	EVERY 25 HOURS	EVERY 50 HOURS	EVERY 100 HOURS	EVERY 200 HOURS	EVERY 500 HOURS
<b>ENGINE</b>							
Consult the engine manual for additional information and instructions							
Check/Top off Engine Coolant Level (Where Applicable)		X					
Check/Top up Oil Level		X					
Check for Leaks		X					
Clean Air Intake Screen		X					
Clean Air Cleaner Precleaner			X*				
Clean Air Cleaner Element					X	X**	
Clean Cooling Fins					X		
Change Oil and Filter	X	See engine manufacturer's manual					
Check/Replace Spark Plugs						X	
* N/A IF EQUIPPED WITH HEAVY DUTY CYCLONIC AIR CLEANER **IF EQUIPPED WITH HEAVY DUTY CYCLONIC AIR CLEANER							
<b>HYDRAULICS</b>							
Check for Leaks		X					
Check/Top up Oil Level					X		
Change Oil and Filter	X						X
<b>MACHINE</b>							
Check Interlock Operation		X					
Check Tire Pressures		X					
Check/Top up Battery					X		
Lubricate All Points				X			



## NOTES

---



---



---



---



---



---



---



---



---



---



---



---



---



---



---



---



---



---



---



---



---



---

GENERAL	DATE	HRS	DATE	HRS	DATE	HRS	DATE	HRS	DATE	HRS	DATE	HRS
	Check tire pressures											
Lubricate all points												
Check nuts & bolts												
ENGINE												
Check Engine Coolant Level (Where Applicable)												
Check oil level												
Change oil												
Clean air cleaner element												
Clean cooling fins												
Replace air cleaner element												
Clean & gap spark plugs												
NOTE: After first 5 hours of operation replace engine oil, hydraulic oil and both filters.												

## CHECK DAILY

### Operator Presence Interlock System - Start Operation

For the engine to crank, the parking brake must be on, the PTO (blades) off and traction levers in the neutral lock position. Sit in the seat and check, one by one, if the engine will crank with the parking brake off, the blades on, and either traction lever out of neutral lock. Also, make sure engine coolant temperature gauge light flashes upon turning key to the **ON** position.

### Operator Presence Interlock System - Run Operation

The operator must be in the seat for the engine to run with the parking brake off, the traction levers moved out of the neutral lock position, or the blades on. To check:

1. Start the engine and run at 1/2 throttle with the operator on the machine but raised off the seat.
2. One by one: move the parking brake to the OFF position, traction levers out of the neutral lock position (check each independently), and turn the blades on. Each check should kill the engine after 1/2 second. (A 1/2 second delay is built into the system to prevent engine cutout when traversing rough terrain.)

Repair machine before using if the Operator Presence Interlock System does not operate correctly in start or run. Contact your authorized CGC, Inc. dealer.

### Hardware

Tighten any nuts and bolts found loose. Replace any broken or missing cotter pins. Repair any other problems before operating.

### Tire pressure

Tires should be kept inflated at 14 lbs/in<sup>2</sup> (1.0 kg/cm<sup>2</sup>). Improper tire inflation can cause rapid tire wear and poor traction. Uneven inflation can cause uneven cutting.

## BATTERY

**⚠ WARNING** Battery acid is caustic and fumes are explosive and can cause serious injury or death.

Use insulated tools, wear protective glasses or goggles and protective clothing when working with batteries. Read and obey the battery manufacturer's instructions.

Be certain the ignition switch is OFF and the key has been removed before servicing the battery.

1. Verify battery polarity before connecting or disconnecting the battery cables.
2. When installing the battery, always assemble the RED, positive ( + ) battery cable first and the ground, BLACK, negative ( - ) cable last.
3. When removing the battery, always remove the ground, negative ( - ) cable first and the red, positive ( + ) cable last.

4. Check the electrolyte level every 100 hours of operation.
5. Clean the cable ends and battery posts with steel wool. Use a solution of baking soda and water to clean the battery. Do not allow the solution to enter into the battery cells.
6. Tighten cables securely to battery terminals and apply a light coat of silicone dielectric grease to terminals and cable ends to prevent corrosion. Keep terminal covers in place.

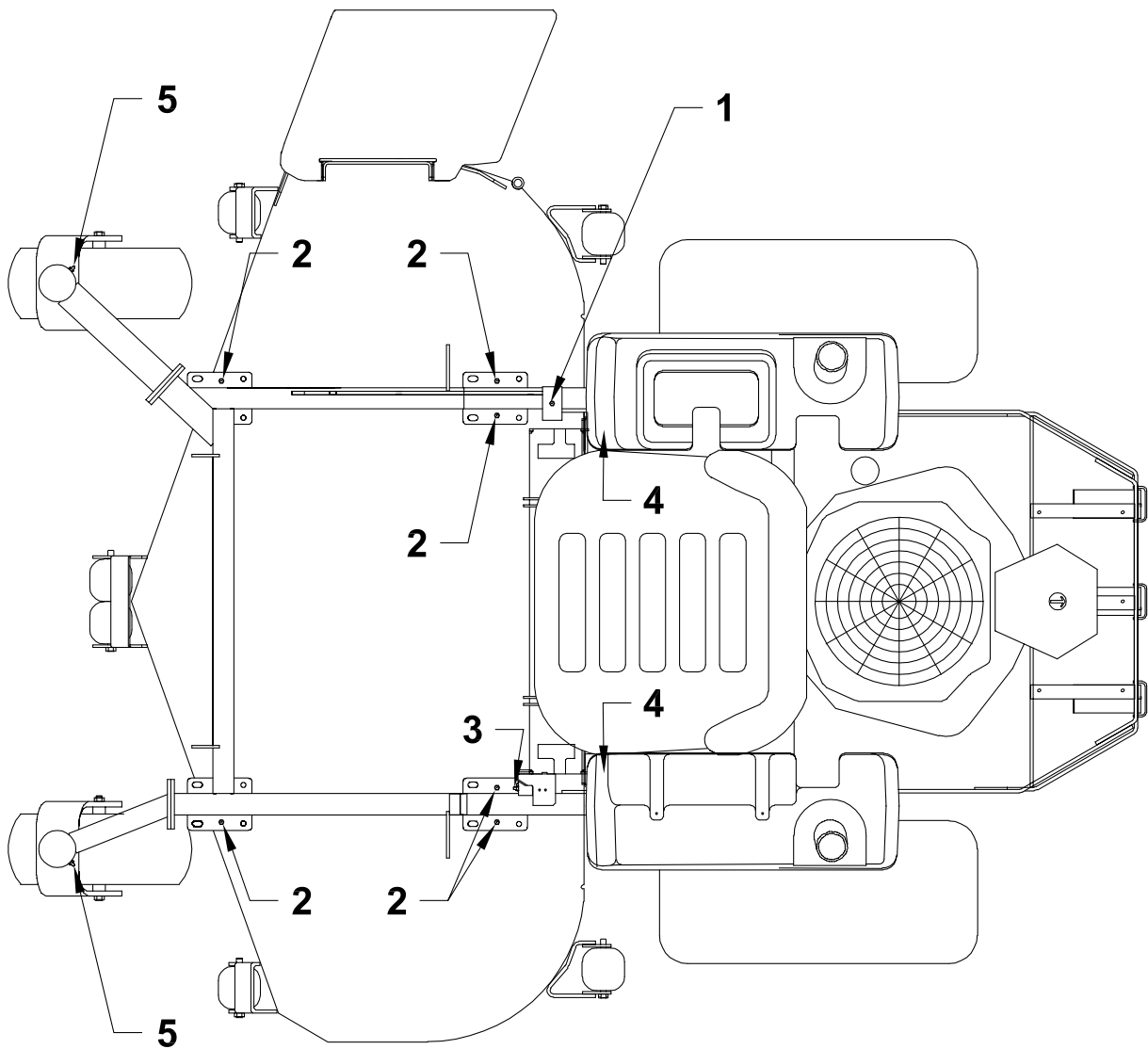

## LUBRICATION

Every 50 hours of operation, lubricate the following points (1-4) with grease:

1. Deck lift rockshaft (1 point)
2. Deck lift pivots (6 points)
3. Brake lever pivot (1 point)
4. Push arms (2 points located at rear of cutterdeck under each fuel tank)
5. Caster wheel pivots (2 points)  
(Lubricate every 500 hours or once a year)

**NOTE ON BLADE SPINDLES** - The blade spindles on these machines use a superior sealed bearing that does not require relubrication.

## HYDRAULIC SYSTEM

Fluid level in the hydraulic system should be checked after the first 5 hours of operation, and every 100 hours thereafter, or when a leak has occurred. If the fluid is low, check all components for leaks.

To check, remove reservoir cap **M**. The fluid level should be at the bottom of the filler tube. If low, top up (do not overfill). Use one of the oils listed below:

- SAE 15W40 motor oil
- SAE 20W50 motor oil
- 15W50 synthetic motor oil

### AFTER FIRST FIVE (5) HOURS

1. Remove plug **N** to drain hydraulic reservoir. Dispose of used oil in accordance with local requirements.
2. Clean and replace the plug.
3. Change hydraulic oil filter **G**.
4. Fill the reservoir with fresh oil to the bottom of the reservoir filler tube, using an oil from the list above. Do not overfill.

### PERIODIC OIL CHANGES

Change the hydraulic fluid and hydraulic filter after each 500 hours of operation using the same procedure given above.

### NOTES:

Before servicing the hydraulic system, stop the engine, disconnect spark plug wires and disengage the PTO.

- After any hydraulic line is opened, plug or cap it promptly to reduce the risk of contamination.
- Do not use sealant tape on hydraulic pipe fittings. Use a liquid sealant that will dissolve into the system.
- Make sure all hydraulic connections are tight and hydraulic hoses and lines are in good condition before applying pressure to system.

### **⚠ WARNING**

The machine's hydraulic system operates under high pressure. When checking for leaks, do not use your hands to attempt to find a leak. Instead, use cardboard or paper. Escaping hydraulic fluid can be under sufficient pressure to penetrate skin and cause serious injury. If hydraulic fluid is injected into the skin, it must be promptly removed by a doctor familiar with this form of injury or gangrene may result.

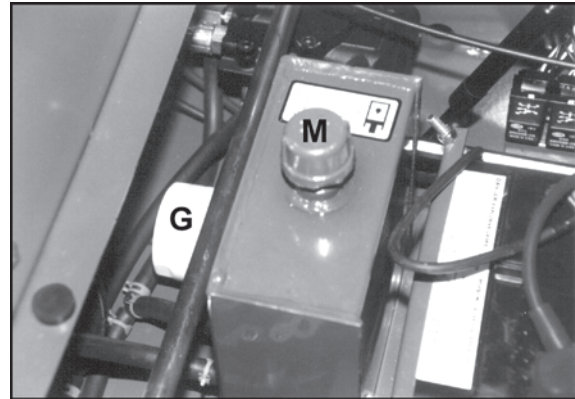

View from right side

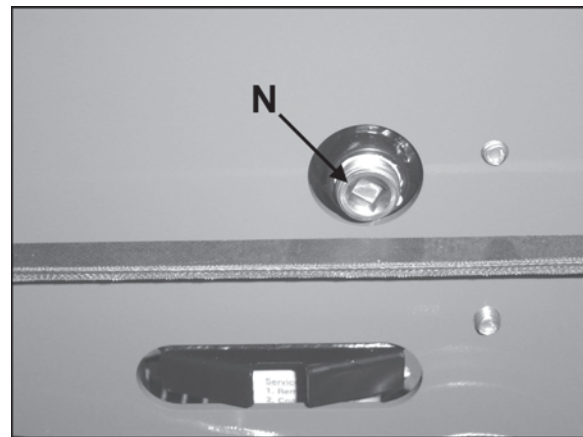

View from below machine

## ENGINE OIL

Do not perform engine maintenance without the engine off, spark plug wires disconnected and PTO disengaged.

### AFTER FIRST FIVE (5) HOURS

While the engine is warm:

1. Remove drain cap **D** and drain the crankcase. Dispose of used oil in accordance with local requirements.
2. Clean and replace the cap.
3. Change oil filter.
4. Fill the crankcase with fresh oil to the full mark. Do not overfill. See engine manual for oil specifications.

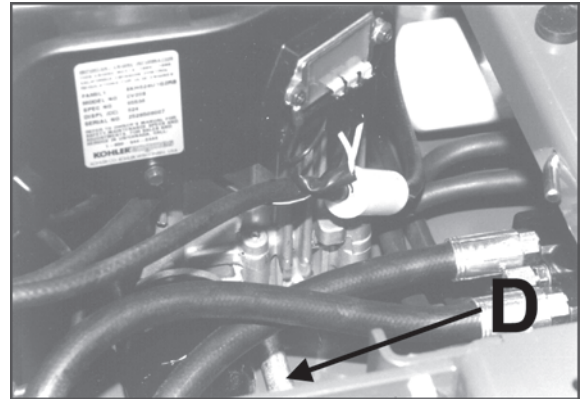

### DAILY

1. Check oil level with the dipstick.
2. If oil is needed, add fresh oil of proper viscosity and grade. See engine manual for oil specifications. Do not overfill.
3. Replace dipstick before starting engine.

### PERIODIC OIL CHANGES

1. See engine manual for oil and filter change intervals after the break-in period.
2. Follow instructions for first oil change, above.

## SPARK PLUGS

Remove each plug and check condition.

- Good operating conditions are indicated if the plug has a light coating of grey or tan deposit.
- A white blistered coating indicates overheating. A black coating indicates an "over rich" fuel mixture. Both may be caused by a clogged air cleaner or improper carburetor adjustment.
- Do not sandblast, wire brush or otherwise attempt to repair a plug in poor condition. Best results are obtained with a new plug.
- Set plug gap as specified in engine manual.

## FUEL FILTER

An inline fuel filter is located in the fuel supply line. Inspect at every oil change to make sure it is clean and unobstructed. Replace if dirty.

## HEAVY DUTY CYCLONIC AIR CLEANER

Clean and replace the air cleaner element as specified in the service chart. Uneven running, lack of power or black exhaust fumes may indicate a dirty air cleaner.

### To replace air cleaner elements:

1. Unclamp end cover **X** and remove existing cleaner elements.
2. Insert new elements **Y** and **Z** and replace cover. Ensure the breathing port **A** is pointing down and towards the front of the tractor.

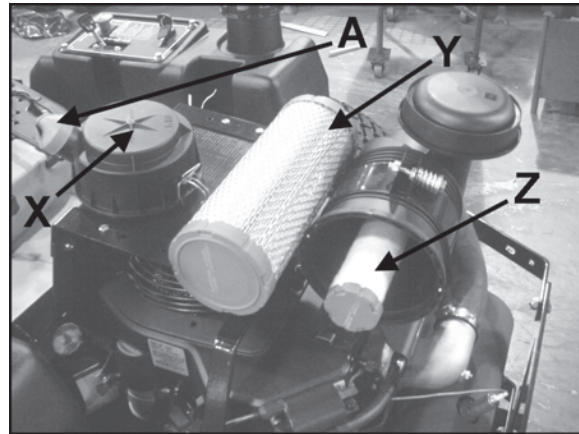

## ENGINE COOLING

Continued operation with a clogged cooling system will cause severe overheating and can result in engine damage.

- **Daily:** Clean air intake screen **S** on air cooled engines and **T** on liquid cooled engines.
- **Every 100 hours:** Clean cooling fins beneath blower housing **H** with reference to information in the engine manufacturer's manual.

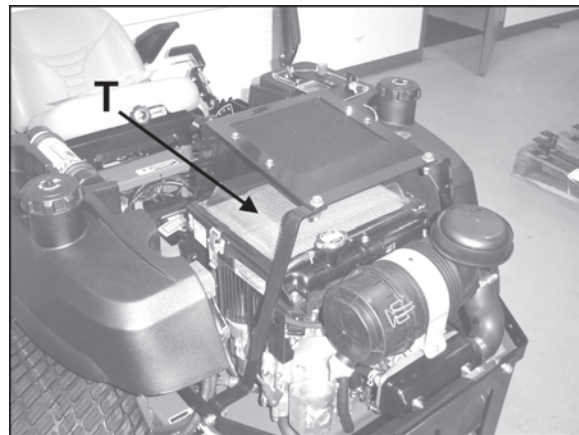
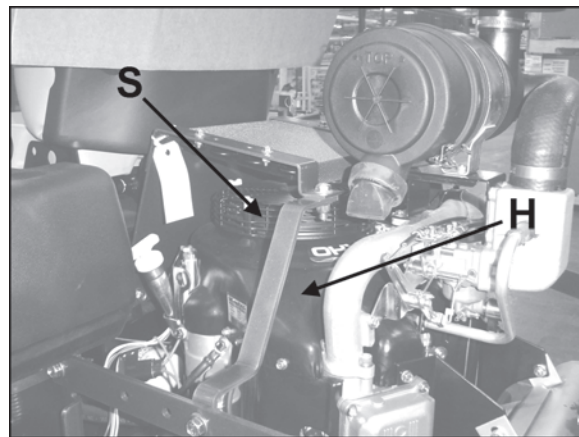



## BLADE REMOVAL

Follow these instructions to prevent injury during blade removal:

1. Loosen with a box wrench or a socket and long breaker bar. To gain additional leverage, slip a long pipe or thick-walled tube over breaker bar or wrench.
2. Insert wood block **A** as shown, with grain perpendicular to blade, to prevent blade from turning when loosening.
3. Wear thickly padded gloves. Keep hands clear of blade path. Blades may rotate when bolt releases.

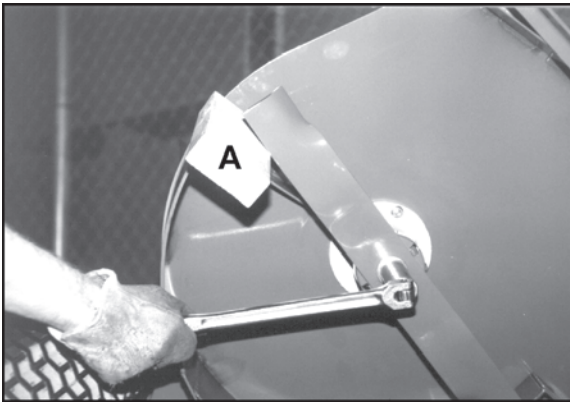

## SHARPENING

Blades may be sharpened by filing or grinding.

- Inspect blades before sharpening.
- Replace bent or cracked blades.
- Replace blades when the lift portion has worn thin.
- Maintain cut angle at 30°.
- Do not overheat blades when sharpening.
- Always use CGC, Inc. blades. Use of another manufacturer's blades may be dangerous.

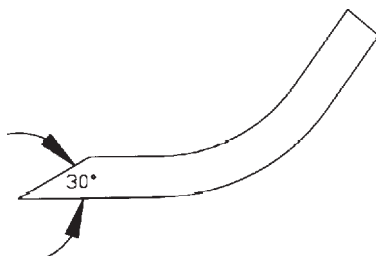

## BLADE BALANCE

Blade balance must be maintained at 5/8 oz-in (19.4 g-cm) or less. Failure to keep blades balanced causes excess vibration, wear, and shortened life of most components of the machine.

### To balance a blade:

1. Sharpen blade first.
2. Balance the blade at the center.
3. Attach a 1/8 oz (3.9 g) weight at a distance of 5" (127 mm) from center on the light end. This should make the light end the heavy end:
  - If it does, the blade is balanced.
  - If does not, file or grind the heavy end until the addition of the weight makes the light end the heavy end.

## BLADE INSTALLATION

1. Wear thickly padded gloves to prevent cuts from the sharp blade.
2. Insert the blade bolt, in order, through the conical washer (cup side toward the blade, as shown), the blade, and the blade spacer.
3. Install assembly on the blade spindle.
4. Torque the blade bolt to 70 ft-lbs.

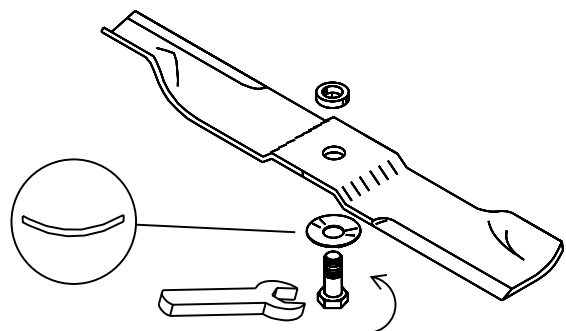



## COUNTERBALANCE SPRINGS

- a) Raise the cutterdeck all the way.
- b) Adjust the spring **A** with nut **B**:
  - 52" cutterdecks to a length of 9-1/8" (232 mm)
  - 61" cutterdecks to a length of 9-9/16" (242 mm)
  - 72" cutterdecks to a length of 10-1/8" (257 mm)

**NOTE:** The springs may be tightened or loosened from this point according to personal preference.

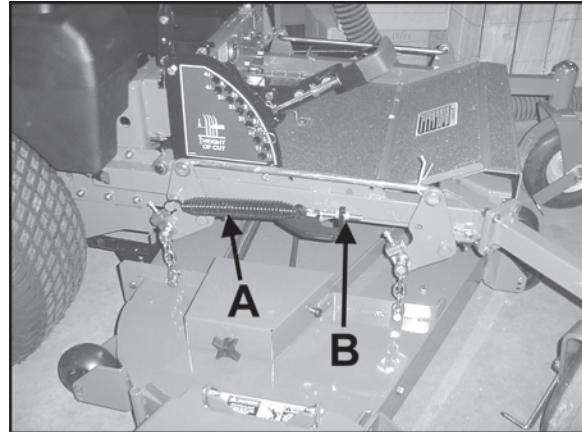

## CONTROL LEVERS

There are two mounting positions for the control levers, upper and lower. The lower position works well for most people. Taller operators may need the upper position.

To adjust the height of the control levers:

- Remove bolts **A** and nuts **B**.
- Align holes in control lever **D** with appropriate holes in traction lever bracket **C**.
- Install bolts **A** and nuts **B**.

The upper mounting hole for the control levers is slotted to allow fore-aft adjustment and to allow alignment of the levers.

To adjust or align the control levers:

- Loosen nuts **B**.
- Adjust control lever position.
- Tighten nuts **B**.

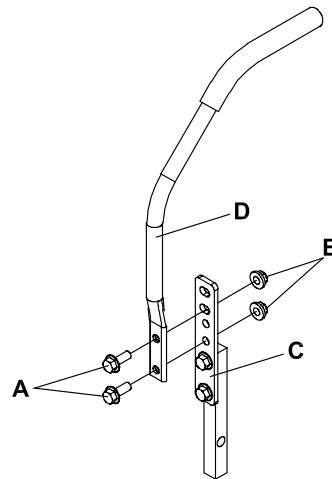

### HEIGHT OF CUT

The height of cut is set by moving height of cut pin **N** to the hole designated for the height of cut desired.

To change the height of cut:

1. Lift the deck to the highest position.
2. Move pin **N** to the selected hole.
3. Lower the deck until the lift lever is stopped by the pin.

#### NOTES:

- Height of cut may vary due to the amount of tread on the tires, tire diameter or inflation pressure.
- For best results, adjust the rear deck rollers for the height of cut to be used (see below).

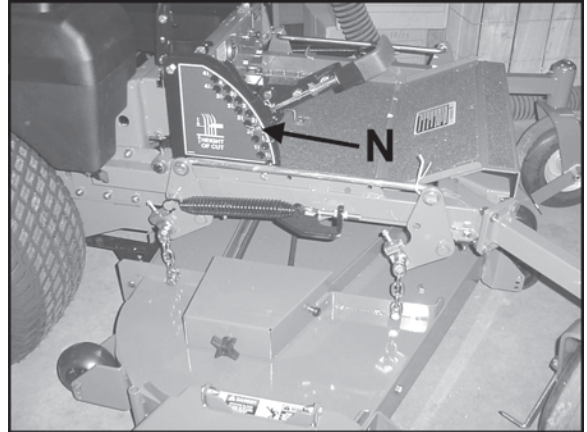

### REAR DECK ROLLERS

The rear outside deck rollers are adjustable up and down to provide improved deck flotation and scalping protection at various heights of cut. They are not intended to ride continuously on the ground. Adjust no closer than 3/8" (10mm) to the ground.

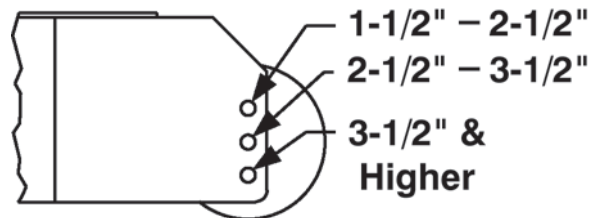

Height of cut ranges for roller adjustment

## PARKING BRAKE

Park machine on a smooth level surface.

Support the machine with the rear wheels off the ground, using jack stands or equivalent. **DO NOT** rely on mechanical or hydraulic jacks.

1. Remove rear wheels.
2. Measure spring length **O** with parking brake **N** in the OFF position.
3. Move parking brake **N** to the ON position and measure length of spring **O** again. When spring deflects 3/8" it is properly adjusted.
4. If adjustment is required, return parking brake **N** to the OFF position.
5. Disconnect one end of rod **M** at the brake and loosen jam nut.
6. Adjust rod **M** in or out as required until 3/8" deflection in brake spring **O** is achieved with parking brake **N** in the ON position.
7. Reconnect rod **M** and retighten jam nut.
8. Repeat steps 2-7 on opposite side of machine.
9. Replace wheels and tighten wheel nuts.

This adjustment will cause the brake springs to stretch 3/8" when the parking brake is in the ON position, providing the correct parking brake force without overloading the brake arm.

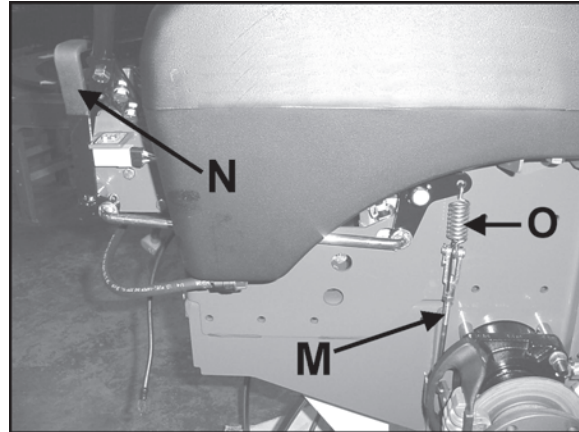

### HYDROSTAT ADJUSTMENTS

A turnbuckle-style hydrostat neutral adjustment is provided.

#### Neutral:

1. Support the machine with the rear wheels off the ground. Use jackstands or equivalent support. Do not rely only on mechanical or hydraulic jacks.
2. Move the traction levers out into the neutral lock position and raise the seat.
3. Disconnect the seat switch wire **K** and temporarily connect the two terminals with jumper wire **J** as shown.
4. Start the engine and run at low speed.
5. Loosen jam nuts **T** at both ends of the turnbuckle.
6. Rotate the turnbuckle until the corresponding wheel stops turning. Lock the turnbuckle jam nuts. Run the engine up to high idle to check the adjustment. Readjust if necessary.
7. Repeat steps 5 and 6 for the opposite side.
8. Remove the jumper wire and reconnect the seat switch.

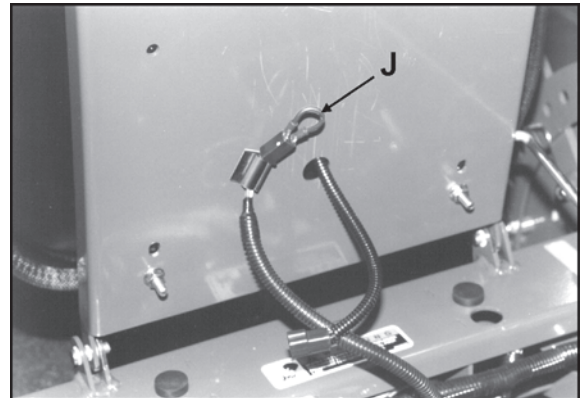
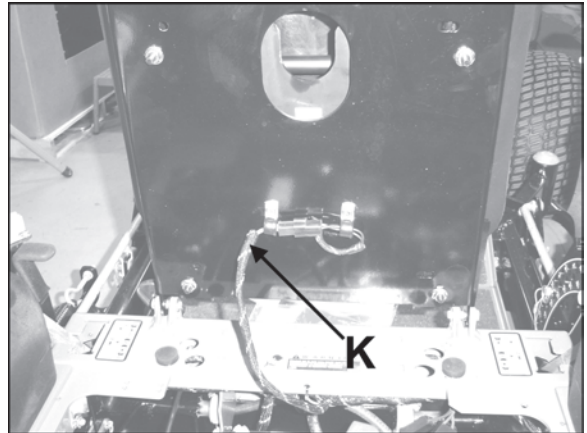

#### Reverse Return:

1. Move traction levers out to the neutral lock position and raise the seat.
2. Locknut **U** should be run on the bolt as far as it will go.
3. Loosen jam nut **Y**. Adjust the clevis yoke by turning the head of the bolt until the clevis pin just makes contact with the rear of the slot in the lever it connects with. Tighten jam nut **Y**.
4. Repeat steps 2 and 3 for the opposite side.

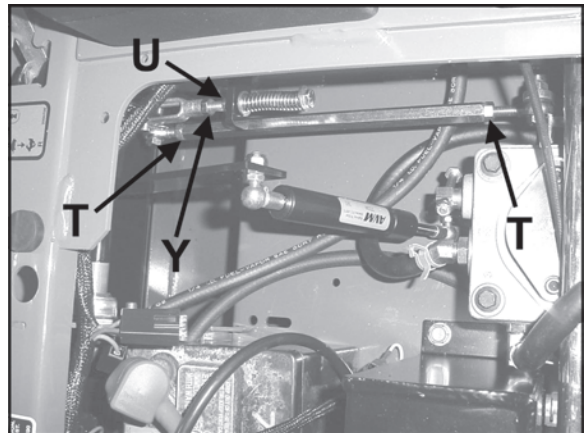

Right side adjustments  
(wiring harness and seat rod removed for clarity)

**NOTE:** A slight creep in reverse is acceptable provided the wheel does not turn and the hydrostat pump does not whine when the parking brake is on.

**Note:** Always use CGC, Inc. replacement belts, not general purpose belts. CGC, Inc. belts are specially designed for use on commercial mowers and will normally last longer.

## ENGINE-CUTTERDECK (PTO) BELT

1. Set the cutterdeck in the lowest height-of-cut position.
2. Attach a short extension to a 3/8" drive ratchet. Insert the ratchet extension into the square hole in the idler arm and use the ratchet to rotate the idler assembly enough to remove the belt. Remove the belt from the idlers and center cutterdeck pulley. Push belt back under engine deck.
3. Disconnect the electric clutch from the wire harness at plug **P**.
4. Remove the carriage bolts securing torque restraint **Q** to clutch **R**. Remove torque restraint.
5. Remove old belt from the machine.
6. Install a new belt by performing the these steps in reverse order.

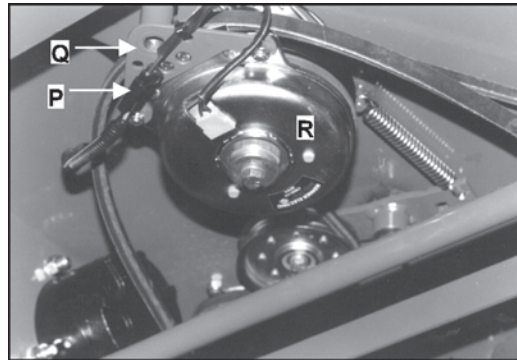
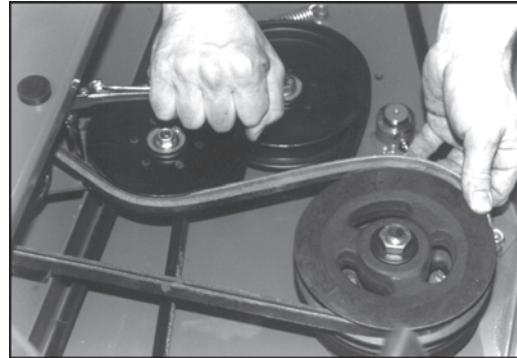

## PUMP-DRIVE BELT

1. Remove engine-cutterdeck belt (see engine-cutterdeck belt replacement).
2. Attach an extension to a 3/8" drive ratchet. Insert the ratchet extension in the square hole of the pump drive idler arm. Use the ratchet handle to rotate it enough to remove the pump drive belt.
3. Install a new pump drive belt in the same manner as it was removed.
4. Re-install engine-cutterdeck belt (see engine-cutterdeck belt replacement).

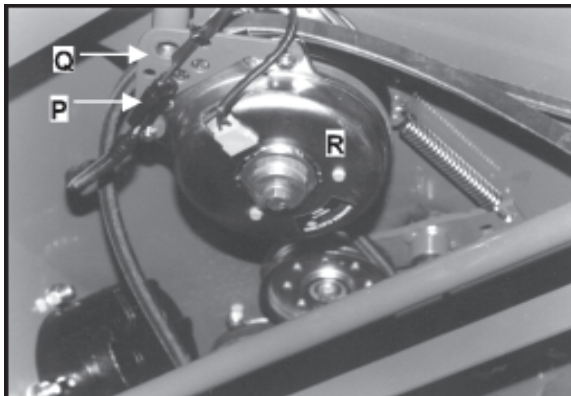



### CUTTERDECK BELT

1. Set the cutterdeck in the lowest height-of-cut position.
2. Remove the engine-cutterdeck belt from the deck idlers and pulley (see engine-cutterdeck belt replacement). Push it aside but don't remove it from the machine.
3. Run the cutterdeck belt off the idler as shown. Remove it from the deck.
4. Install the new belt by performing these steps in reverse order. Take care to get the new belt on the correct side of the belt guides.
5. Re-install engine-cutterdeck belt (see engine-cutterdeck belt replacement).

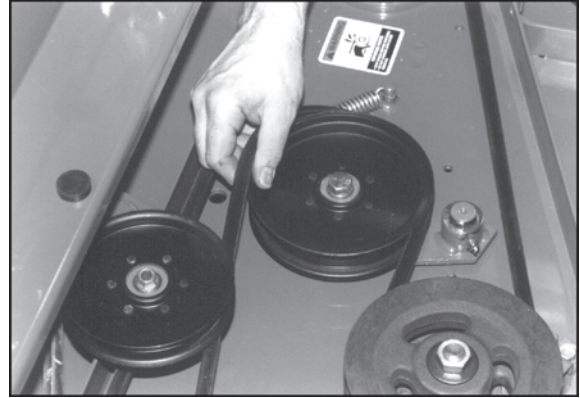

## POWER UNITS

### ENGINES:

**Construction:** Aluminum block with cast iron cylinder liners. Aluminum head.

**Configuration:** 4-stroke, vertical shaft, V-twin cylinder, overhead valve.

### DRIVE SYSTEM:

Full hydrostatic pump and wheel motor combination for independently controlled drive wheels.

**Pump:** Hydrogear PJ-2HCA-EYIX with shock valves 12cc variable displacement piston pump.

**Motors:** Parker/Ross 15 cu.in. displacement MB series. Direct drive 1-1/4" (31.8mm) diameter output shaft.

**Turn Radius:** True Zero

### OPERATOR PRESENCE INTERLOCK SYSTEM:

**Start:** The PTO (blades) must be off, traction levers in neutral lock, and parking brake on for engine to crank.

**Run:** Operator must be in seat to take parking brake off, to move traction levers out of the neutral lock position, or to turn the PTO (blades) on or the engine will kill. The parking brake must be off for the traction levers to move out of the neutral lock position.

The operator may leave the seat with the engine running if the parking brake is on, the PTO (blades) is off, and the traction levers are in the neutral lock position. A time delay eliminates annoying engine cutout from operation over rough terrain.

### WEIGHT:

1025 lbs (465 kg) with 52" or 61" cutterdeck.  
1315 lbs (596 kg) with 72" cutterdeck.

### CONTROLS:

Throttle; choke; power takeoff (PTO) clutch switch; traction levers; parking brake lever; lift lever.

### FUEL SYSTEM:

One tank on each side of operator, each with a shutoff (1/4 turn). Total capacity 12 gallons (45 liters). Fuel selector/shutoff switch on front panel (1/4 turn). Replaceable fuel filters.

### MAXIMUM GROUND SPEEDS:

**Forward:** 10.2 mph (16.4 km/h)  
@ 3600 engine rpm.  
**Reverse:** 4.8 mph (7.7 km/h)  
@ 3600 engine rpm.

### WHEELS & TIRES:

#### Drive wheels:

942240E:	23x10.50-12 4-Ply Turf Tread Tires
942241E, 942242E & 942245E:	24x12.00-12 4-Ply Turf Tread Tires

<b>Casters:</b>	52" Deck	13x5.00-6 4-ply rib tread tires
	61" & 72" Deck	13x6.50-6 4-ply rib tread tires

**Pressure:** 14 p.s.i. (1 kg/cm<sup>2</sup>)

### BRAKING:

Hayes disc type parking brakes. Spring applied for overload protection.

### SEAT:

High back, foam padded full suspension seat with standard armrests. Fore and aft adjusters, hinged for easy tilt-up access to pumps and battery. Internally mounted seat switch.



# PREDATOR-PRO SERIES

# SPECIFICATIONS

ENGINE				
<b>MODEL NUMBERS</b>	942240E	942241E	942242E	942245E
<b>MANUFACTURER</b>	Generac	Generac	Generac	KAWASAKI
<b>MODEL</b>	GTV760	GTV990	GTV990	FD731V
<b>CYLINDERS</b>	2	2	2	2
<b>COOLING</b>	AIR	AIR	AIR	LIQUID COOLED
<b>BORE/STROKE</b>	3.54 X 2.64" (90 X 60 mm)	3.54 X 3.07" (90 X 78mm)	3.54 X 3.07" (90 X 78mm)	2.96 X 2.99 (75.2 X 76mm)
<b>DISPLACEMENT</b>	46 cu. in. (763 cc)	60 cu. in. (992cc)	60 cu. in. (992cc)	41.2 cu. in. (675cc)
<b>COMPRESSION</b>	8.6:1	8.6:1	8.6:1	8.5:1
<b>OUTPUT POWER</b>	26 hp (19.4 kw) @ 3600 rpm	33 hp (24.6 kw) @ 3800 rpm	33 hp (24.6 kw) @ 3800 rpm	26 hp (19.4 kw) @ 3600 rpm
<b>LUBRICATION</b>	FULL PRESSURE	FULL PRESSURE	FULL PRESSURE	FULL PRESSURE
<b>GOVERNOR</b>	Mechanical	Mechanical	Mechanical	Mechanical
<b>AIR CLEANER</b>	Heavy Duty Cyclonic	Heavy Duty Cyclonic	Heavy Duty Cyclonic	Heavy Duty Cyclonic
<b>IGNITION SYSTEM</b>	Electronic	Electronic	Electronic	Electronic
<b>CHARGING SYSTEM</b>	20 amp, regulated	20 amp, regulated	20 amp, regulated	20 amp, regulated
<b>BATTERY</b>	BCI group U1	BCI group U1	BCI group U1	BCI group U1
<b>FUSES</b>	Two, 20 amp blade	Two, 20 amp blade	Two, 20 amp blade	Two, 20 amp blade

FLUID CAPACITIES	QUANTITY	TYPE	FILTER
<b>FUEL</b>	12 gal. (46 l)	REGULAR, UNLEADED GASOLINE	REPLACEABLE
<b>ENGINE OIL</b>	2.1 qts (2.01 l) W/FILTER	SAE 10W30	SPIN-ON REPLACEABLE
<b>HYDRAULIC OIL</b>	2.6 qts (2.46 l)	SAE 15W40 MOTOR OIL, SAE 20W50 MOTOR OIL, 15W50 SYNTHETIC	25 MICRON SPIN-ON REPLACEABLE

CUTTERDECKS			
MODEL NUMBER	942240E	942241E, 942245E	942242E
TYPE	Side Discharge	Side Discharge	Side Discharge
CUTTING WIDTH	52.5" (133 cm)	61" (155 cm)	71.5" (181 cm)
WIDTH	N/A	N/A	N/A
WIDTH (CHUTE UP)	56.25" (143 cm)	62.0" (157 cm)	72.5" (184 cm)
WIDTH (CHUTE DOWN)	64.5" (164 cm)	73.0" (185 cm)	84.0" (213 cm)
BLADE	high lift (low lift optional)	high lift (low lift optional)	high lift (low lift optional)
NUMBER OF BLADES	3	3	3
BLADE LENGTH	18" (46 cm)	21" (53 cm)	24.5" (63 cm)
BLADE THICKNESS	.205" (5.2 mm)	0.25" (6.35 mm)	0.25" (6.35 mm)
TIP SPEED	18397 ft/min 5607 m/min @ 3600 Engine RPM	18100 ft/min 5517 m/min @ 3800 Engine RPM	18153 ft/min 5533 m/min @ 3800 Engine RPM
DAILY PRODUCTION (8 hr @ 6 mph)	Up to 25.5 acres (10.3 ha)	Up to 29.5 acres (11.9 ha)	Up to 34.7 acres (14.0 ha)

### CONSTRUCTION:

52-61 Fabricated and welded 10-gauge, double-layer steel top with 7-gauge side skirts. 72 7ga top with 10 ga stiffener and 7 ga sideskirts. Full floating design.

### CUTTERDECK DRIVE SYSTEM:

Electric clutch/brake drives belt directly from engine to center spindle of cutterdeck. No twists in drive belt.

### SPINDLES:

Top mounted and maintenance free, with 1" shaft in precision machined, aluminum housing

### ANTI-SCALP ROLLERS:

52" Cutterdecks - 6 Roller  
61" Cutterdecks - 7 Rollers  
72" Cutterdecks - 7 Rollers

### CUTTING HEIGHT & PRODUCTION:

**Height:** Spring assisted lift lever allows easy setting of cut heights from 1-1/2" to 4-1/2" in 1/4" increments. "Set and forget" feature allows height of cut to be set and returned to without searching from operator position.

### SPECIFIC TORQUES

BLADE BOLT TORQUE: 70 FT-LBS (95 Nm)  
WHEEL HUB NUTS: 225 FT-LBS (237 Nm)  
ENGINE CRANKSHAFT BOLT: 50 FT-LBS (68 Nm)  
KAWASAKI LIQUID COOLED CRANKSHAFT BOLT  
40 - 45 FT LBS (54 - 61 Nm)



# UPPER ENGINE DECK ASSY

# PREDATOR-PRO SERIES

FIGURE 1

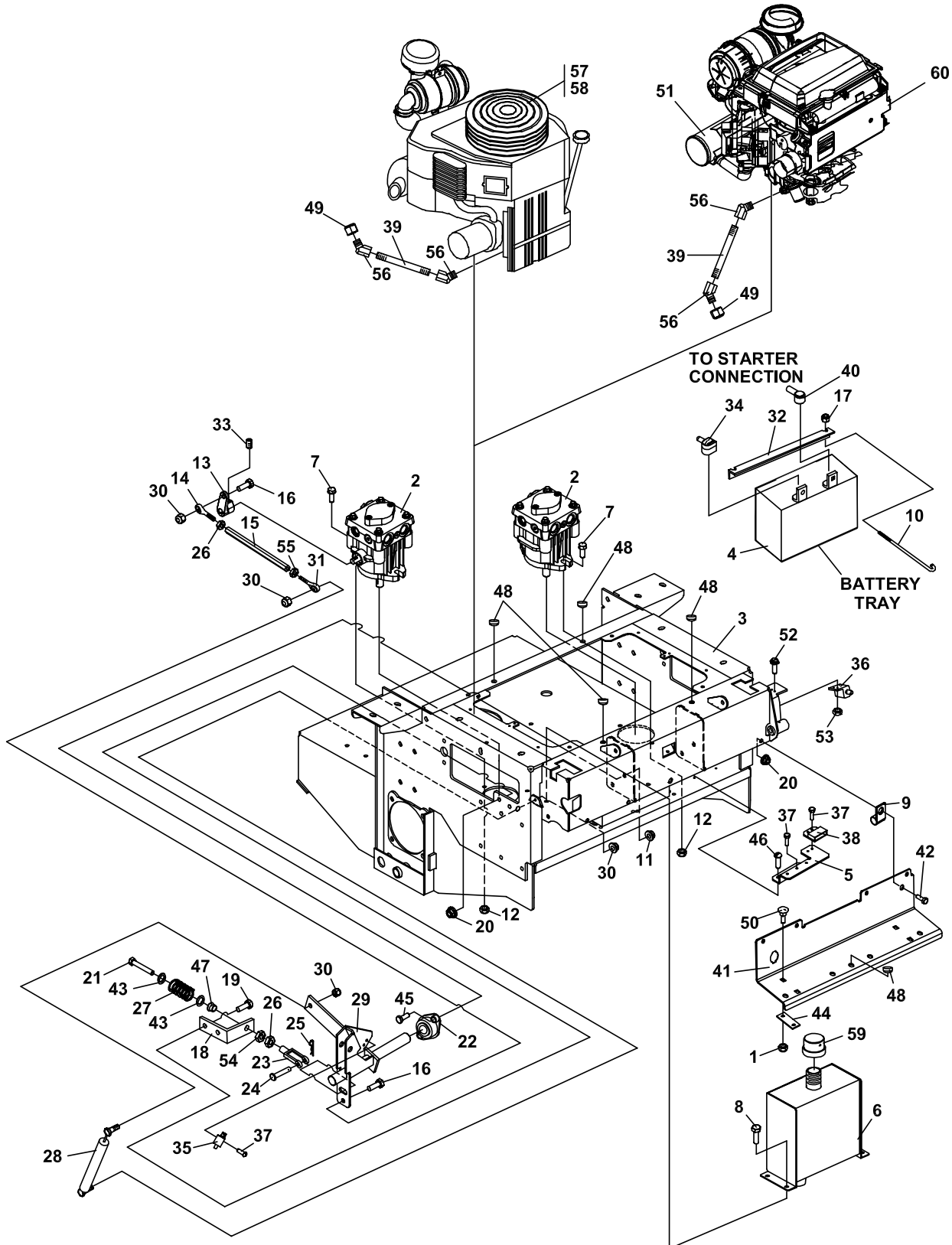

# PREDATOR-PRO SERIES

# UPPER ENGINE DECK ASSY

## FIGURE 1

ITM	PART NO.	DESCRIPTION	QTY	ITM	PART NO.	DESCRIPTION	QTY
1	64268-03	NUT-FL NYLON LOCK 3/8-16	4	49	118036	HEX CAP 3/8 PIPE	1
2	4157242	PUMP-HYDROSTATIC (SEE FIGURE 8 FOR BREAKDOWN)	2	50	64018-23	BLT-CRG 3/8-16X3/4	4
3	4136780	S-ENGINE DECK W/LABS	1	51	4146795	MUFFLER-KAW LC	1
4	108055	BATTERY	1	52	64152-46	SCREW-SLT HH 10-24X1/2	2
5	4138859.7	BRACKET-RELAY MNTG	1	53	64025-15	NUT-HEX #10-24 KEPS	2
6	2186211	S HYD RESERVOIR W/LABS	1	54	64229-08	LOCKNUT NYLON 5/16-24	2
7	64263-013	BLT-FLG HD M10-1.5 X 30	4	55	64025-33	NUT-HEX 5/16-24 LH	2
8	64197-016	BLT-TDFM 3/8-16X1/2	4	56	2722175	FITTING-45 DEG.STR EL 3/8	2
9	48228-2A	CLAMP	1	57	4135206	ENG-26HP GEN GTV760	1
10	831861	BOLT,BENT BATT HOOK	2	*	2198147-01	ELEMENT	1
11	64141-4	NUT-WLF 3/8-16	8	*	4135662	AIR FILTER SECONDARY	1
12	64237-03	LOCKNUT-NYLON M10-1.5	4	*	4135663	OIL FILTER	1
13	4159521	ARM-PUMP	2	*	4136930	SPARK PLUG	1
14	38369-02	ROD END BALL JOINT LH	2	*	4136939	GASKET-VALVE COVER	1
15	2188140	TURNBUCKLE	2	58	4135208	ENG-33HP GEN GTV990	1
16	64205-003	BLT-MET M8-1.25X30	4	*	2198147-01	ELEMENT	1
17	64229-02	LOCKNUT-NYLON 5/16-18	2	*	4135662	AIR FILTER SECONDARY	1
18	2182405.7	BRKT-REVERSE RETURN	2	*	4135663	OIL FILTER	1
19	A1104057	BOLT-M10-1.50X25	4	*	4136930	SPARK PLUG	1
20	64246-03	NUT-WHIZ M10-1.50	8	*	4136939	GASKET-VALVE COVER	1
21	64123-205	BLT-HEX 5/16-24X4	2	59	69216.7	CAP-RESERVOIR	1
22	2188145	BEARING-.75IDSELF-ALIGN	4	60	4147162	ENGINE-26HP KAW L.C.	1
23	38020N	CLEVIS YOKE, 5/16 PLATE	2		4114746	S-AIR FILTER PRIMARY	1
24	64188-02	PIN, CLEVIS 5/16X1	2		4114747	S-AIR FILTER SAFETY	1
25	64168-2	COTTER-HAIRPIN.08X1.19	2		2722214	FILTER-OIL	1
26	64025-03	NUT-HEX 5/16-24	4		38666	FILTER-FUEL	1
27	2188139	SPRING-COMPRESSION	2				
28	2721246	DAMPENER	2				
29	4112105.7	WLDMT-MOTION CTRL RH	1				
*	4112104.7	WLDMT-MOTION CTRL LH	1				
30	64237-05	LOCKNUT-NYLON M8-1.25	8				
31	38369-01	ROD END BALL JOINT RH	2				
32	2182427.7	HOLDDOWN-BATTERY	1				
33	64192-06	SETSCR SQHD 5/16-18X3/4	2				
34	112386	BOOT,BAT TERM POS	1				
35	108208	SWITCH DBL POLE	2				
36	2188156	SWITCH-NONO DBL POLE	1				
37	64197-015	BLT-TDFM 10-32X1/2 TORX	8				
38	2188154	MODULE-DELAY	1				
39	48024-22A	NIPPLE-PIPE 3/8NPTF X 2.5	1				
40	2308095	COVER-TERMINAL	1				
41	4158086.7	PLATE-KICK	1				
42	64263-011	BLT-FLG HD M10-1.5 X 20	4				
43	64163-55	WASHER .328X.75X14 GA	4				
44	2188146	STRIP, WEAR	2				
45	64123-15	BOLT-3/8-16X3/4 HEX	8				
46	64152-23	1/4-20X3/8 LG SP SCREW	2				
47	38304-02	BRG, FLGD PLASTIC	2				
48	810149	BUMPER-RUBBER	8				

\* NOT ILLUSTRATED

# LOWER ENGINE DECK ASSY/CLUTCH

# PREDATOR-PRO SERIES

FIGURE 2

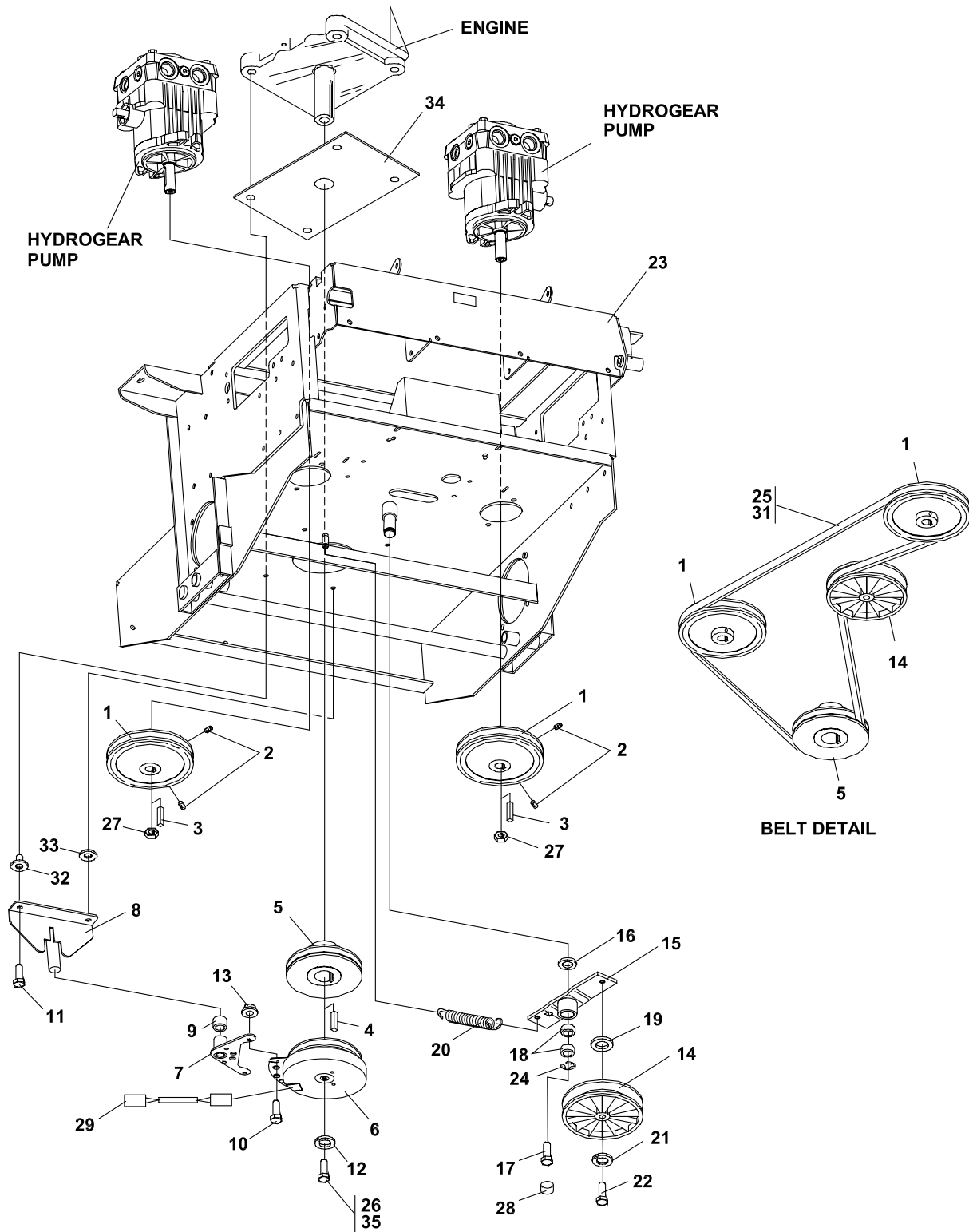

TORQUE TO 50 FT/LBS +/-10%

# PREDATOR-PRO SERIES

# LOWER ENGINE DECK ASSY/CLUTCH

FIGURE 2

ITM	PART NO.	DESCRIPTION	QTY	ITM	PART NO.	DESCRIPTION	QTY
1	4157180	PULLEY-PUMP	2				
2	64044-1	SCREW-SET 1/4-20X1/4	4				
3	64164-29	KEY-3/16 x 3/4 SQ	2				
4	64164-10	1/4X1/4X1-1/4 MACH KEY	1				
5	4157240	PULLEY-4.25 ODX1.25 BORE (USED WITH 33HP MODELS ONLY)	1				
	4157860	PULLEY-4.25 ENGINE (USED WITH 26HP MODEL ONLY)	1				
6	2721337	CLUTCH-ELECTRIC (INCLUDES ITEMS 29 & 30)	1				
7	2721338.7	WLDMT-CLUTCH STOP	1				
8	2186147.7	WLDMT-CLUTCH BRACKET	1				
9	38304-03	BEARING-FLANGED PLSTC	1				
10	64205-001	BOLT-MET M8-1.25X20	2				
11	64197-005	BOLT-TDFM 3/8-16X1-1/4	4				
12	64006-06	LCKWSHER-HELICAL 7/16	1				
13	64265-04	NUT-FL NYL LOCK M8-1.25	2				
14	2308000	PULLEY-IDLER 4.00 EOD	1				
15	4128923	S-ASSY-IDLER ARM PUMP (INCLUDES ITEMS 16, 18 & 24)	1				
16	4127999	SEAL-16 X 24 X 7	1				
17	64270-01	BOLT-MET HEX M10-1.5x30	1				
18	4128004	BEARING-BALL 10 X 26 X 8	2				
19	33148-01	SPACER-0.379X0.750X0.25	1				
20	38219	SPRING-TENSION	1				
21	64006-03	WSHR, 3/8 HELICAL LOCK	1				
22	64123-21	BOLT-HEX 3/8-24X1-1/4	1				
23	4136780	S ENG DECK W/LABS	1				
24	64144-40	SNAP RING-26MM INTRNL	1				
25	4124830	BELT-PUMP DRIVE HA 67.35	1				
26	64123-155	BOLT-HEX 7/16-20X3	1				
27	64025-41	NUT	2				
28	4128002	END CAP-26 X 7	1				
29	2720949	ASSY-CLUTCH WIRE	1				
30*	4121560	KIT-BRAKE POLE RPLCMNT	1				
(ITEMS 31 - 35 USED ON MODEL 942245E ONLY)							
31	4157920	BELT-PUMP DRIVE	1				
32	4144405	PLUG-ENGINE DECK MOUNT	1				
33	64163-31	WASHER	1				
34	4144216.7	PLATE-ENGINE KAW LC	1				
35	64205-079	BLT-MET M10-1.5X70	1				

\* NOT ILLUSTRATED



# BUMPER

# PREDATOR-PRO SERIES

FIGURE 3

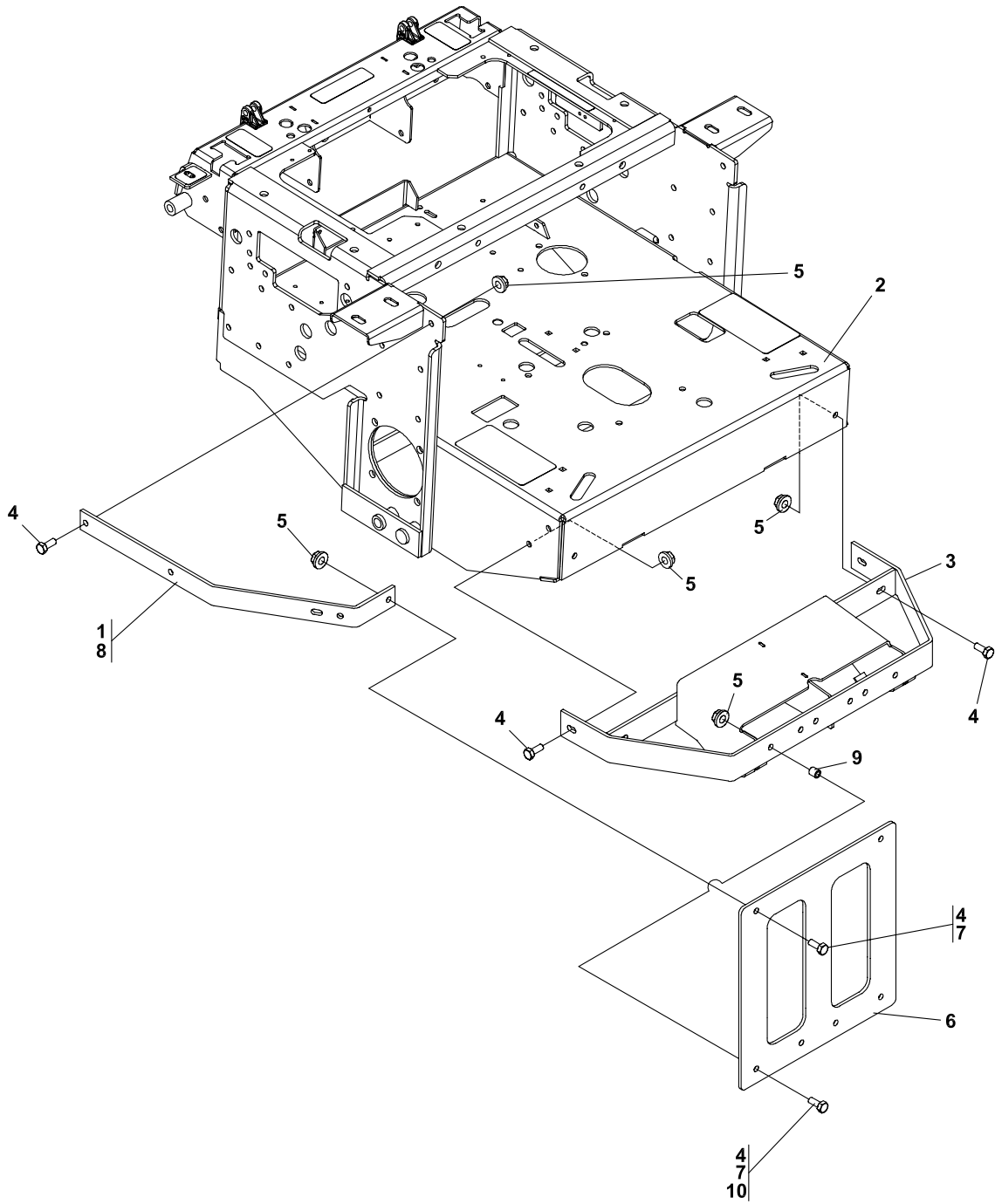

# PREDATOR-PRO SERIES

# BUMPER

## FIGURE 3

ITM	PART NO.	DESCRIPTION	QTY	ITM	PART NO.	DESCRIPTION	QTY
1	2722296.7	ARM-BUMPER	2				
2	4138697	S ENG DECK W/LABS	1				
3	2721324.7	WLDMT-BUMPER	1				
4	64263-013	BLT-FLG HD M10-1.5 X 30 (QTY 12 USED ON 52" & 61" DECKS ONLY) (QTY 6 USED ON 72" DECKS ONLY) (QTY 8 USED ON MODEL 942245E ONLY)					
5	64265-05	NUT-FL NYL LOCK M10-1.5	12				
6	2721932.7	BRACE-VERTICAL (QTY 1 USED ON 52" & 61" DECKS ONLY) (QTY 11 USED ON 72" DECKS ONLY)					
7	64205-012	S BLT-MET M10-1.50 X 90 (USED ON 72" DECKS ONLY)	6				
		(ITEMS 8 - 10 USED ON MODEL 942245E ONLY)					
8	4146349.7	BRACE-BUMPER	2				
9	2183071-03	SPACER	4				
10	64263-023	BLT-MET M10-1.5X50	4				



# PREDATOR-PRO SERIES

# FUEL TANKS/CONTROL PANEL

## FIGURE 4

ITM	PART NO.	DESCRIPTION	QTY	ITM	PART NO.	DESCRIPTION	QTY
1	4142548	TANK-FUEL LH (INCLUDES ITEMS 18 & 19)	1				
2	4142549	TANK-FUEL RH (INCLUDES ITEMS 18 & 19)	1				
3	4159162	S-CONTROL PANEL	1				
4	4136780	S ENG DECK W/LABS	1				
5	4160281	DOC TUBE	1				
6	4130320	CAP-FUEL GASOLINE 3.5	2				
7	4110023	PLUG-SWITCH HOLE (QTY 1 USED ON MODEL 942245E ONLY) (QTY 2 USED MODELS 942240E, 41E & 42E)					
8	64205-007	BLT MET M10-1.50X20	12				
9	38061A	VINYL CAPS	1				
10	2188178	SWITCH-RETAINER	1				
11	64263-001	BLT-FLG HD M6-1.0 X 12	5				
12	88042N	HOSE CLAMP	6				
13	128010	KEY-SWITCH	1				
14	118020-16	CONTROL-THROTTLE 48.0	1				
15	2721505	SWITCH-PTO	1				
16	64025-15	NUT-HEX #10-24 KEPS	2				
17	64152-46	SCR.-SLT HH #10-24X1/2	2				
18	4132325	GROMMET-FUEL TANK	2				
19	38540	VALVE-FUEL W/FILTER	2				
20	800488	LOCKWASHER M10	8				
21	64251-004	WASHER-M10	8				
22	2188161	VALVE-TANK SELECTOR	1				
23	48016-13A	HOSE,.25IDX.50ODX2 LG	1				
24	48016-21A	HOSE-.25IDX.50ODX1.84 LG	1				
25	48016-22A	HOSE-.25IDX.50ODX1.67 LG	1				
26	38666	FILTER, FUEL B&S	1				
27	128010-01	S-KEY SWITCH NYLON NUT	1				
28	128010-03	S-COVERED KEY	1				
29	4158086.7	PLATE-KICK	1				
30	48228-2a	CLAMP-3/4	1				
31	64246-03	NUT-WHIZ M10-1.50	4				
32	4146392	CLUSTER-WARNING LIGHT (USED ON MODEL 942245E ONLY)	1				
33	108009-05	CONTROL-CHOKE 55"	1				
34	64025-04	NUT-HEX 3/8-24	1				
35	64263-002	BOLT-M6-1 X 16	2				
36	4142266	PLUG	1				



# PREDATOR-PRO SERIES

# BRAKES/REAR WHEEL

## FIGURE 5

ITM	PART NO.	DESCRIPTION	QTY	ITM	PART NO.	DESCRIPTION	QTY
1	4136780	S-ENGINE DECK W/LABS	1	31	450767	CAPSCREW 12-1.75X110 (USED ON 52" & 61" DECKS ONLY)	8
2	4158803.7	WLDMT-BRAKE ARM LH	1		64223-10	CAPSCREW- M12-1.75 X 150 (USED ON 72" DECKS ONLY)	8
3	4158801.7	WLDMT-BRAKE ARM RH	1				
4	128102	SPRING,EXTENSION	2				
5	4159241.7	WLDMT-BRAKE LEVER	1				
6	4159701	ROD-SPD CTRL UPPER (USED ON 52" & 61" ONLY)	2	32	64164-08	S-KEY FOR WHEEL MOTOR	2
				33	64025-31	NUT 1-20 UNSLOTTED TRW	2
7	2182387.7	GUIDE-SPRING	2				
8	38020N	CLEVIS YOKE, 5/16 PLATE	2				
9	4159281	ASSY-BRAKE	2				
10	64163-06	WSHR,.768/.756X1.25X14	A/R				
11	4159000	SHAFT, BRAKE	1				
12	4159280	MOTOR-PARKER (INCLUDES ITEMS 32 & 33)	2				
13	4158421	TIRE-23 X 10.5-12 (ITEM 13 USED ON 942240E)	2				
14	4158422	TIRE-24 X 12-12 (ITEM 14 USED ON 942241E, 42E & 45E)	2				
15	64187-03	WHEEL NUT-1/2-20	8				
16	64188-02	PIN, CLEVIS 5/16X1	2				
17	64061-25	ROLL PIN-1/4X1-1/4	2				
18	2188155	GRIP, 1/4X1X4-1/2	1				
19	2183063-01	SPACER, 32MM LONG (USED ON 52" & 61" DECKS ONLY)	8				
	2183063-05	SPACER (USED ON 72" DECKS ONLY)	16				
20	4159700	ROD-BRAKE CONTROL (USED ON 72" DECKS ONLY)	2				
21	85010N	ZERK, 1/4-28 STR SLFTHRD	1				
22	64144-34	SNAP RING.50	1				
23	2188145	BEARING-.75ID SELF ALIGN	2				
24	64123-15	BOLT-3/8-16X3/4 HEX	4				
25	64141-4	NUT-WLF 3/8-16	4				
26	64207-07	NUT-HEX M12-1.75	8				
27	64168-2	COTTER-HAIRPIN.08X1.19	6				
28	64025-03	NUT-HEX 5/16-24	2				
29	64006-05	LOCKWSHR-HELICAL 1/2	8				
30	4159242	WLDMT-PRK BRAKE ROD	1				

# OIL COOLER

# PREDATOR-PRO SERIES

FIGURE 6

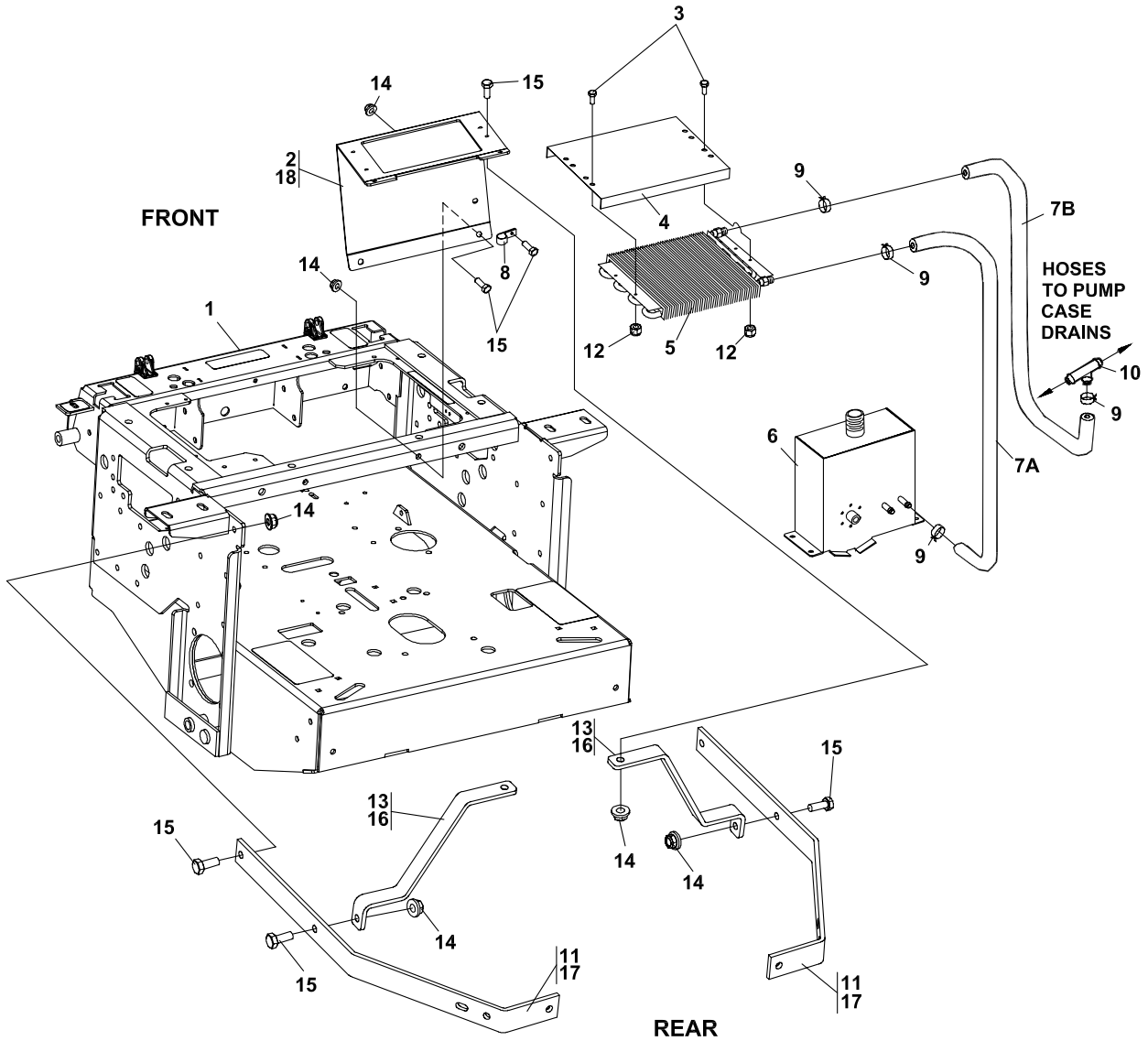



# PREDATOR-PRO SERIES

# OIL COOLER

## FIGURE 6

ITM	PART NO.	DESCRIPTION	QTY	ITM	PART NO.	DESCRIPTION	QTY
1	4136780	S ENGINE DECK W/LABS	1				
2	4139443.7	BRKT-COOLER FRONT	1				
3	64263-002	BLT-FLG HD M6-1.0 X 16	4				
4	2720891.7	SCREEN-OIL COOLER	1				
5	2188173	COOLER-OIL	1				
6	2186211	S HYD RSRVR W/LABS	1				
(69053-05 IS A SERVICEABLE LENGTH OF 55")							
7A	69053-05	3/8 HIGH TEMP HOSE 26"	1				
7B	69053-05	3/8 HIGH TEMP HOSE 22"	1				
8	48228-2A	CABLE-CLIP 3/4 W/INSTN	2				
9	88042-04	CLAMP-3/4 CLIP	4				
10	58026-01	3 WAY CONNECTOR 3/8	1				
11	2722296.7	ARM-BUMPER	2				
12	64237-02	LOCKNUT-NYLON M6-1.00	4				
13	4139367.7	BRACKET-REAR COOLER	2				
14	64265-05	NUT-FL NYL LOCK M10-1.5	9				
15	64263-013	BLT-FLG HD M10-1.5 X 30	9				
(ITEMS 16 - 18 USED ON MODEL 942245E ONLY)							
16	4146309.7	BRKT-REAR OIL COOLER LC	2				
17	4146349.7	BRACE-BUMPER	2				
18	4146310.7	BRKT-MNTNG OIL COOLER	1				

## FIGURE 7

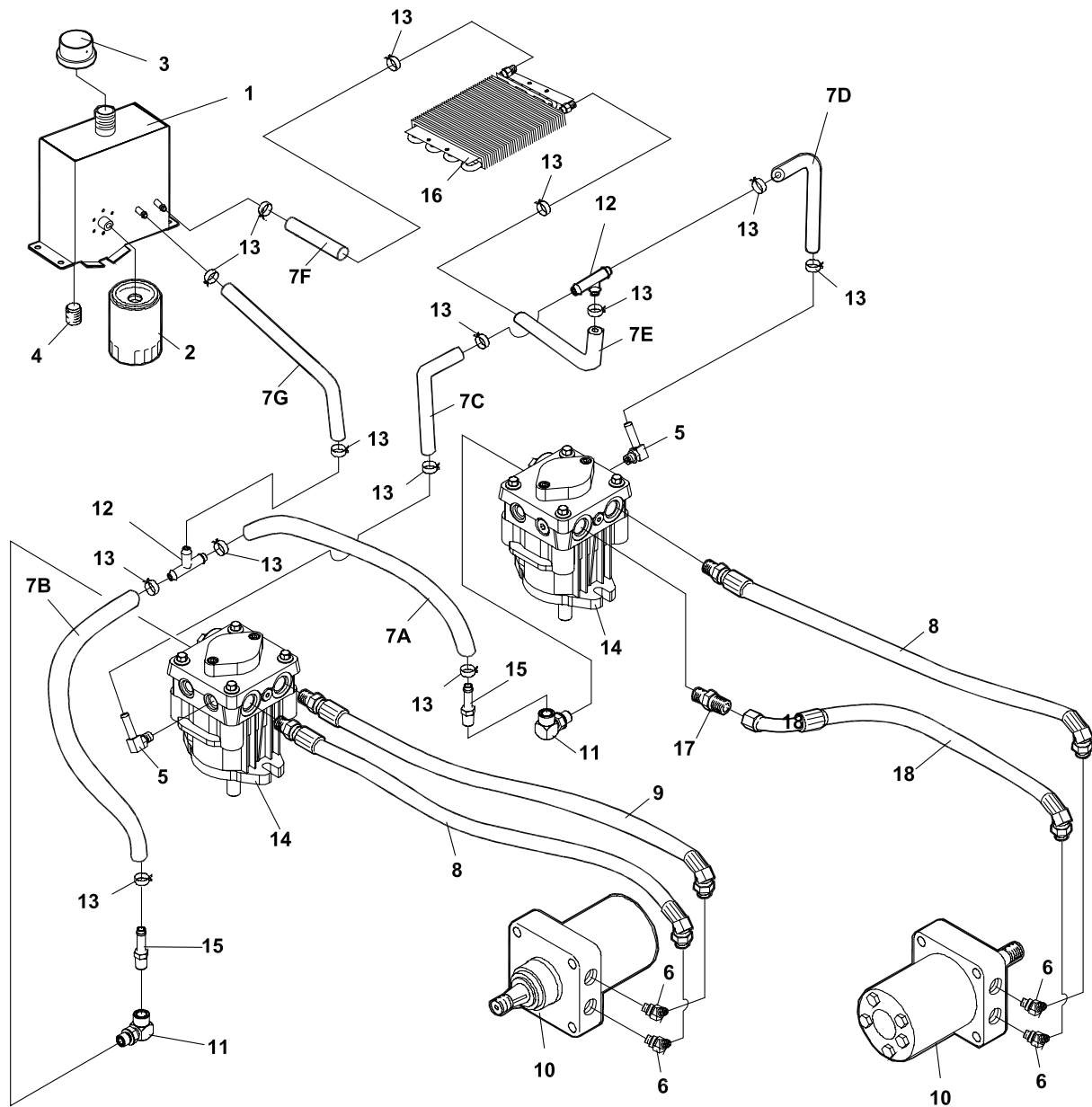

# PREDATOR-PRO SERIES

# HYDRAULICS

## FIGURE 7

ITM	PART NO.	DESCRIPTION	QTY
1	2186211	S HYD RESERVOIR W/LAB	1
2	2720396	FILTER 25 MICRON	1
3	69216.7	CAP-RESERVOIR	1
4	4160243	PLUG-MAGNETIC	1
5	158058-04	FTG-90 BRB 9/16-18X.38	2
6	108205-03	ELBOW-MALE 45 37-ORB	4
(69053-05 IS A SERVICEABLE LENGTH OF 55")			
7A	69053-05	3/8 HIGH TEMP HSE 18"	1
7B	69053-05	3/8 HIGH TEMP HSE 15"	1
7C	69053-05	3/8 HIGH TEMP HSE 19"	1
7D	69053-05	3/8 HIGH TEMP HSE 12"	1
7E	69053-05	3/8 HIGH TEMP HSE (22" USED ON AIR COOLED ENGINES) 26" USED ON LIQUID COOLED ENGINES)	1
7F	69053-05	3/8 HIGH TEMP HSE (26" USED ON AIR COOLED ENGINES) (35" USED ON LIQUID COOLED ENGINES)	1
7G	69053-05	3/8 HIGH TEMP HSE 5"	1
8	2188157-01	HOSE HYD ORB 37-22.38	2
9	2188157-02	HOSE HYD ORB 37-25.00	2
10	4159280	MOTOR-PARKER	2
11	158058-17	FITTING-90 BARB, ADJ.	2
12	58026-01	3 WAY CONNECTOR 3/8	2
13	88042-04	CLAMP-HOSE 5/8	14
14	4157242	PUMP-HYDRO 16CC	2
15	48386-04	FITTING-3/8 BARB 1/4	2
16	2188173	OIL COOLER	1
17	48089-03	FTG-STRT 8 ORB X 8 JIC	1
18	2720320-01	HOSE-1/2 37/45 37 26.25	1

SAE PORT 'O' RING		
PART NUMBER	THREAD SIZE	AS-568#
158061-10	9/16-18	-906
158061-11	3/4-16	-908
158061-12	7/8-14	-910
158061-13	1-1/16-12	-912
158061-14	1-5/16-12	-916
158061-16	1-5/8-12	-920
158061-03	1-7/8-12	-924

FIGURE 8

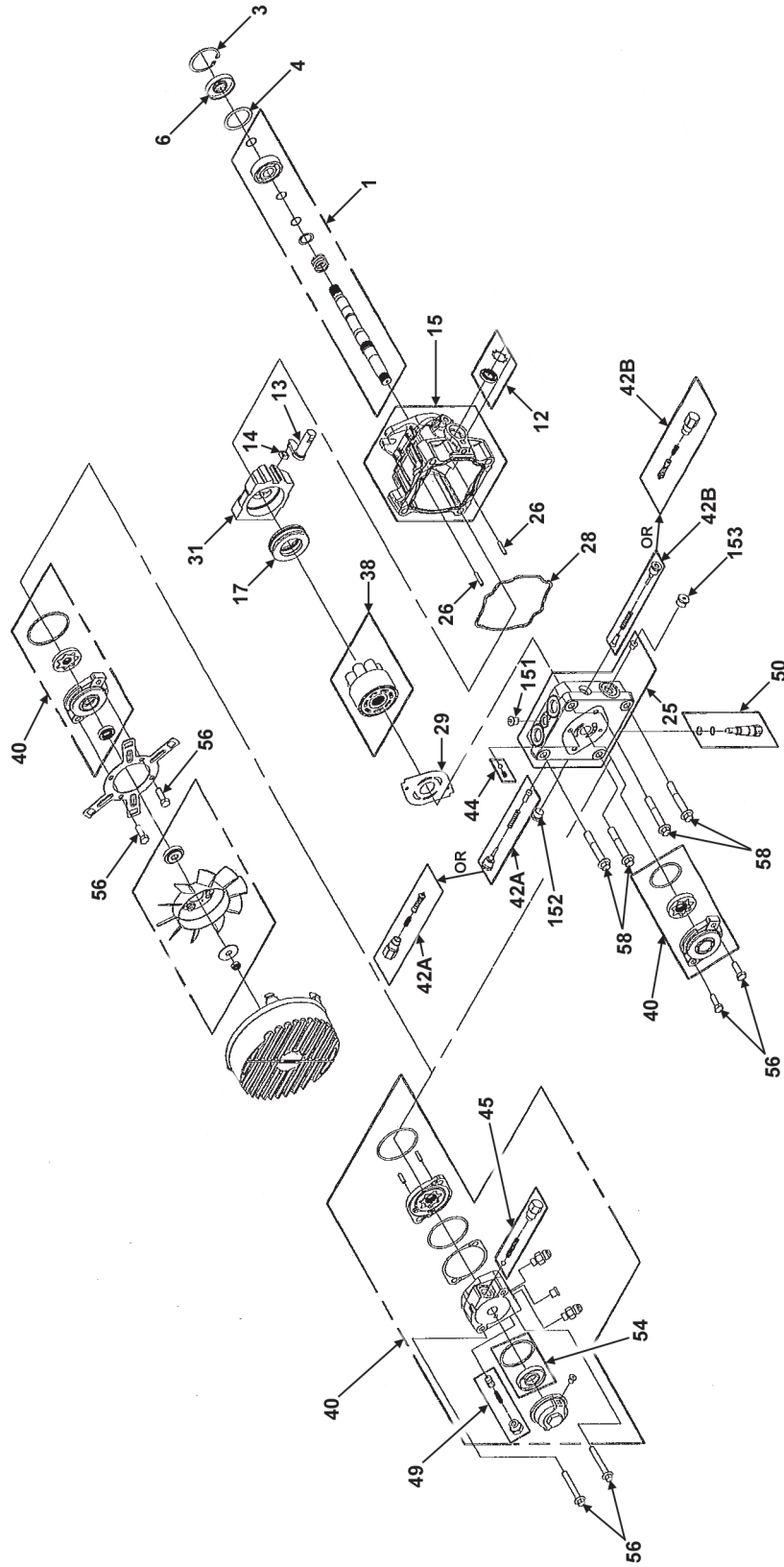

100 - OVERHAUL SEAL KIT

# PREDATOR-PRO SERIES

# HYDROGEAR PUMP

## FIGURE 8

ITEM	HYDROGEAR PART NO.	CGC, INC. PART NO.	DESCRIPTION	QTY
1	71019	4157242-001	PUMP SHAFT KIT-TAPERED	1
3	2000038	4157242-002	RETAINING RING	1
4	2000023	4157242-003	SPACER	1
6	51092	4157242-004	LIP SEAL	1
12	70739	4157242-005	TRUNNION SEAL/RETAINER	1
13	2000014	4157242-006	TRUNNION ARM	1
14	2000015	188059-09	SLOT GUIDE	1
15	70738	4157242-007	HOUSING KIT	1
17	51462	4157242-008	BALL THRUST BEARING	1
25	70736	4157242-009	END CAP KIT W/POPPETS	1
26	50641	4157242-010	STRAIGHT HEADLESS PIN	2
28	51437	4157242-011	HOUSING O-RING	1
29	52371	4157242-012	VALVE PLATE	1
31	51436	4157242-013	SWASHPLATE	1
38	70735	4157242-014	CYL BLOCK KIT (16 cc)	1
40	2510071	4157242-015	CHARGE PUMP KIT	1
42A	70743	4121354	SHOCK VALVE KIT (0.031" ORF)	1
42B	70741	4121355	SHOCK VALVE KIT (BLANK)	1
44	70402	4157242-016	CHARGE RELIEF VALVE KIT	1
45	2510082	4157242-017	AUX RELIEF VALVE KIT	1
49	2510020	4157242-018	AUX BYPASS/CHECK KIT	1
50	2513030	4157242-019	BYPASS VALVE KIT (BLANK)	1
54	2510090	4157242-020	AUX FILTER KIT	1
56	50173	4157242-021	BOLT-M8-1.25 X 25	2
58	51457	4157242-022	FH M10 X 65	4
100	70740	4157242-023	OVERHAUL SEAL KIT	1
151	9005110-4400	4157242-024	STRAIGHT THREAD PLUG	1
152	9005100-5600	4157242-025	9/16 STEEL PLUG	1
153	9005100-5600	4157242-025	9/16 STEEL PLUG	1

# GENERAC WIRE HARNESS

# PREDATOR-PRO SERIES

FIGURE 9

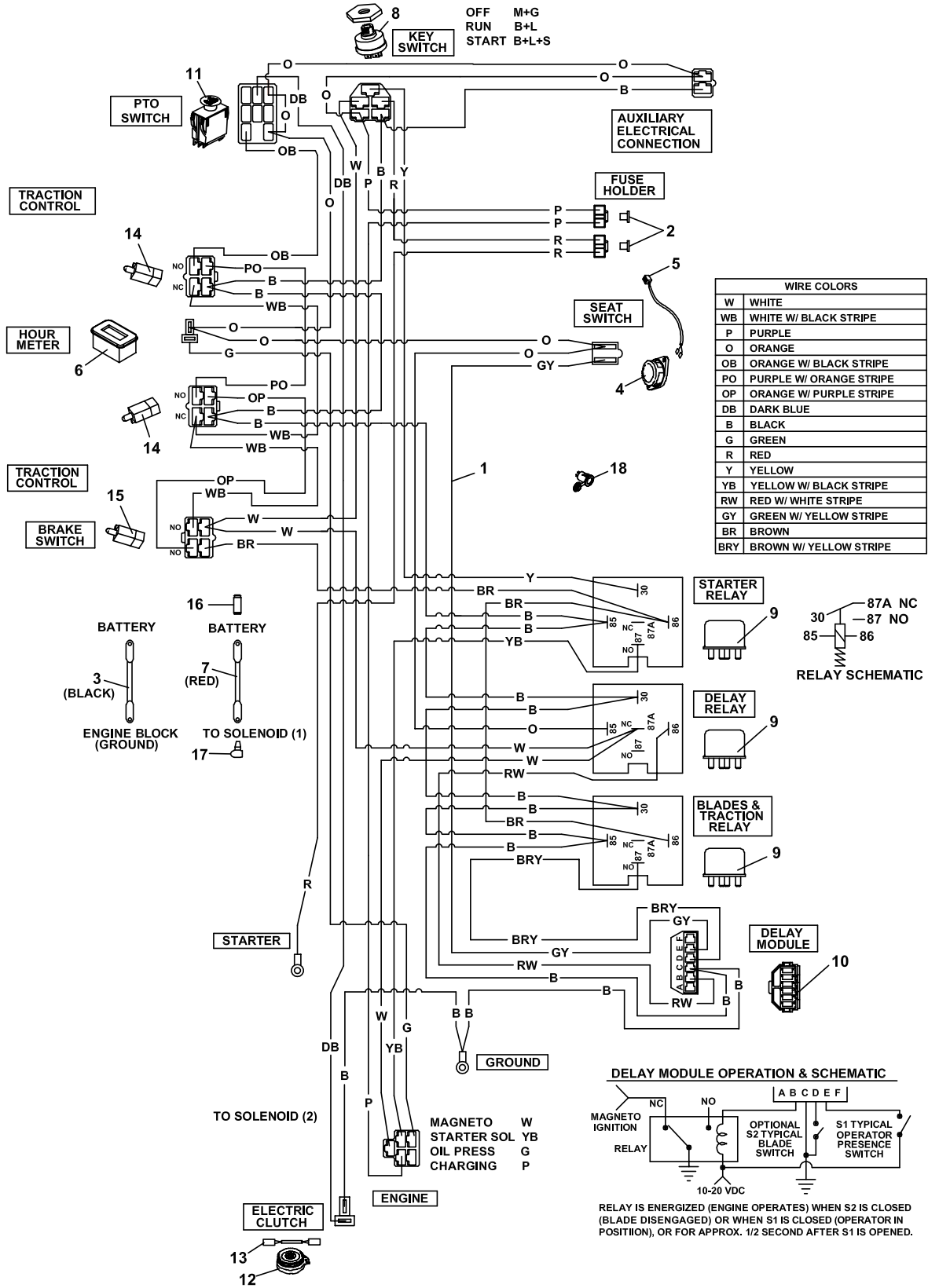

WIRE COLORS	
W	WHITE
WB	WHITE W/ BLACK STRIPE
P	PURPLE
O	ORANGE
OB	ORANGE W/ BLACK STRIPE
PO	PURPLE W/ ORANGE STRIPE
OP	ORANGE W/ PURPLE STRIPE
DB	DARK BLUE
B	BLACK
G	GREEN
R	RED
Y	YELLOW
YB	YELLOW W/ BLACK STRIPE
RW	RED W/ WHITE STRIPE
GY	GREEN W/ YELLOW STRIPE
BR	BROWN
BRY	BROWN W/ YELLOW STRIPE

# PREDATOR-PRO SERIES

# GENERAC WIRE HARNESS

FIGURE 9

ITM	PART NO.	DESCRIPTION	QTY	ITM	PART NO.	DESCRIPTION	QTY
1	4158085	HARNESS-WIRING MAIN	1				
2	148082-20	FUSE-20 AMP	2				
3	108061-13	CABLE-BATTERY 36 BLACK	1				
4	4124009	SWITCH-SEAT, NO	1				
5	4143068	WIRE-SEAT SWITCH	1				
6	4136792	METER-HOUR	1				
7	2722227-02	CABLE-BATT W/CONDUIT (INCLUDES ITEMS 20 & 21)	1				
8	128010	KEY-SWITCH	1				
9	2722325	RELAY-40AMP SEALED	3				
10	2188154	MODULE-DELAY	1				
11	2721505	SWITCH-PTO	1				
12	2721337	CLUTCH-ELECTRIC (INCLUDES 2720949 WIRE ASSY)	1				
13	2720949	ASSY-CLUTCH WIRE	1				
14	108208	SWITCH-DBL POLE	2				
15	2188156	SWITCH-NONO DBL POLE	1				
16	112386	BOOT-BAT TERM POS	1				
17	2308095	COVER-TERMINAL	1				
18	4142266	CONNECTOR-12V	1				



FIGURE 10

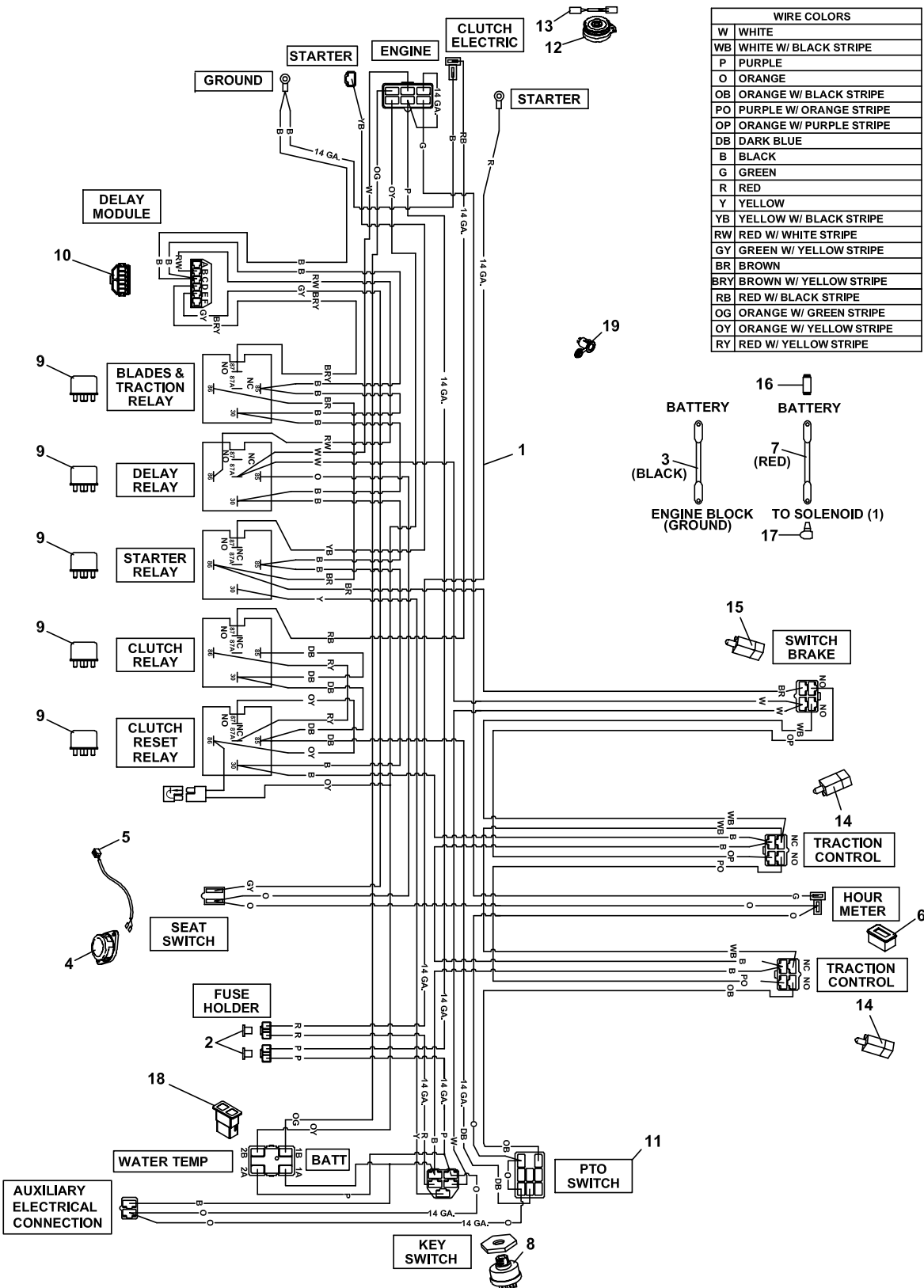

WIRE COLORS	
W	WHITE
WB	WHITE W/ BLACK STRIPE
P	PURPLE
O	ORANGE
OB	ORANGE W/ BLACK STRIPE
PO	PURPLE W/ ORANGE STRIPE
OP	ORANGE W/ PURPLE STRIPE
DB	DARK BLUE
B	BLACK
G	GREEN
R	RED
Y	YELLOW
YB	YELLOW W/ BLACK STRIPE
RW	RED W/ WHITE STRIPE
GY	GREEN W/ YELLOW STRIPE
BR	BROWN
BRY	BROWN W/ YELLOW STRIPE
RB	RED W/ BLACK STRIPE
OG	ORANGE W/ GREEN STRIPE
OY	ORANGE W/ YELLOW STRIPE
RY	RED W/ YELLOW STRIPE

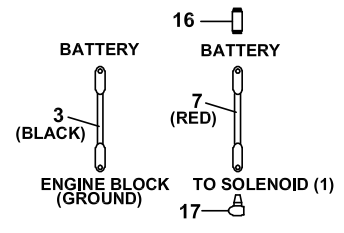

# PREDATOR-PRO SERIES

# KAWASAKI WIRE HARNESS LC

FIGURE 10

ITM	PART NO.	DESCRIPTION	QTY	ITM	PART NO.	DESCRIPTION	QTY
1	4159365	HARNESS-WIRING LC	1				
2	148082-20	FUSE-20 AMP	2				
3	108061-13	CABLE-BATTERY 36 BLACK	1				
4	158135-01	SWITCH-SEAT, NO	1				
5	158136	WIRE-SEAT SWITCH	1				
6	4136792	METER-HOUR	1				
7	2722227-02	CABLE-BATT W/CONDUIT (INCLUDES ITEMS 20 & 21)	1				
8	128010	KEY-SWITCH	1				
9	2722325	RELAY-40AMP SEALED	5				
10	2188154	MODULE-DELAY	1				
11	2721505	SWITCH-PTO	1				
12	2721337	CLUTCH-ELECTRIC (INCLUDES 2720949 WIRE ASSY)	1				
13	2720949	ASSY-CLUTCH WIRE	1				
14	108208	SWITCH-DBL POLE	2				
15	2188156	SWITCH-NONO DBL POLE	1				
16	112386	BOOT-BAT TERM POS	1				
17	2308095	COVER-TERMINAL	1				
18	4146392	CLUSTER-WARNG LIGHT LC	1				
19	4142266	CONNECTOR-12V	1				

FIGURE 11

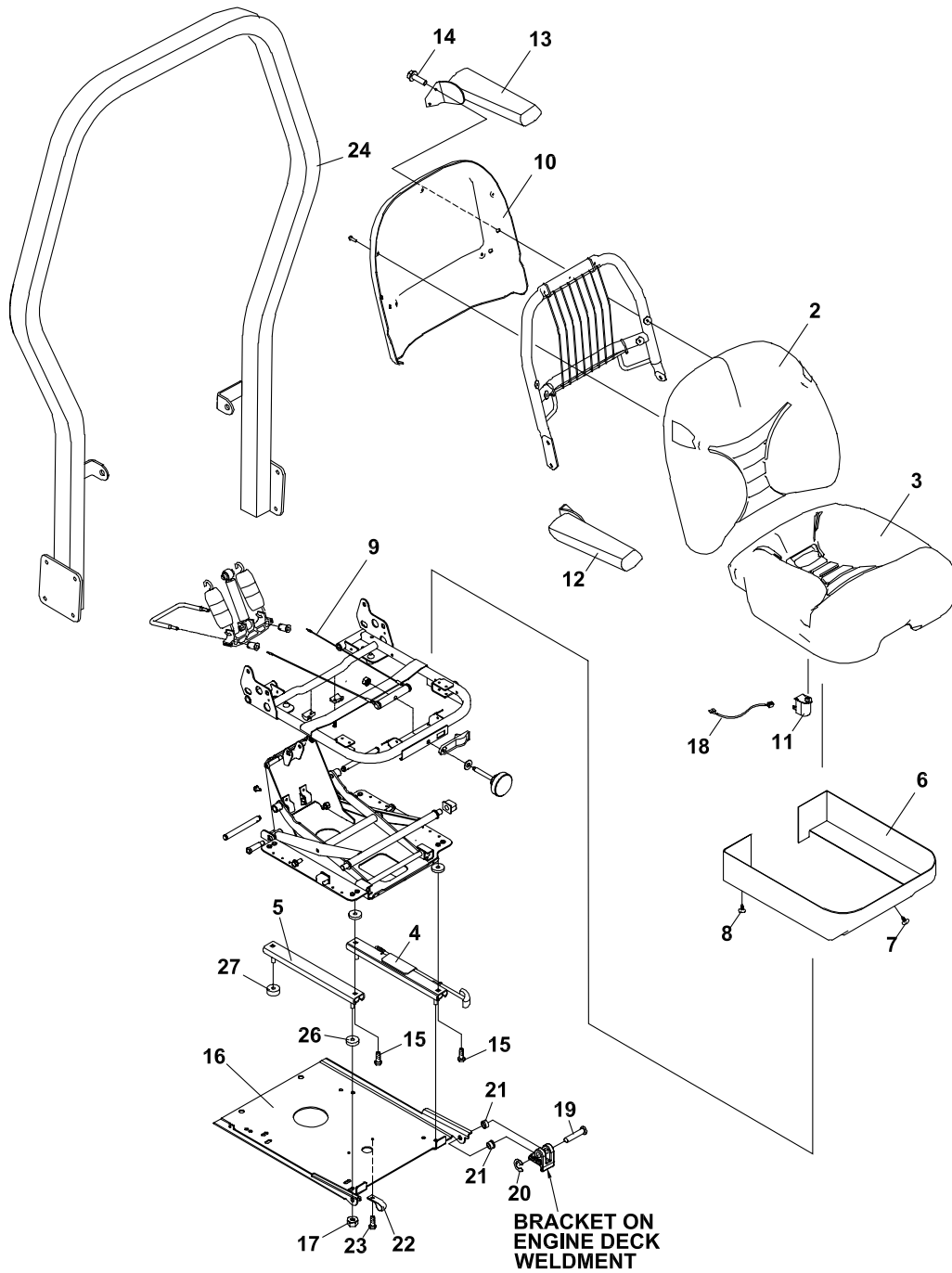

# PREDATOR-PRO SERIES

# SEAT ASSEMBLY & ROPS

FIGURE 11

ITM	PART NO.	DESCRIPTION	QTY	ITM	PART NO.	DESCRIPTION	QTY
1	4122479	SEAT-SUSPENSION (INCLUDES ITEMS 2-15)	1				
2	4122479-01	CUSHION-SEAT BACK	1				
3	4122479-02	CUSHION-SEAT BOTTOM	1				
4	4122479-03	SLIDE RAIL-ADJUSTER	1				
5	4122479-04	SLIDE RAIL-SLAVE	1				
6	4122479-05	SKIRT-SEAT ASSY	1				
7	4122479-06	CLIP-SMALL XMAS TREE	3				
8	4122479-07	CLIP-LARGE XMAS TREE	4				
9	4122479-08	ASSY-CABLE	1				
10	4122479-09	BACK PANEL-SEAT	1				
11	4124009	SWITCH-SEAT NO	1				
12	4122481	ARMREST-RH	1				
13	4122480	ARMREST-LH	1				
14	64123-68	BOLT-HEX 5/16-18X1	4				
15	64123-54	BOLT, 5/16-18X3/4 HEX	4				
16	4121386.7	PLATE-SEAT	1				
17	64141-6	NUT-WLF 5/16-18	4				
18	4143068	WIRE-SEAT SWITCH	1				
19	33138-09	PIN-CLEVIS GRVD	2				
20	64144-30	SNAP RING	2				
21	38371-01	BRG-NYLINER 3/8	4				
22	48228A	CABLE CLIP-INSULATED	2				
23	64152-23	SCREW 1/4-20X3/8	2				
<b>OPTIONAL ROPS:</b>							
24	970162	ATT-ROPS (INCLUDES ITEM 25)					
25*	2208260	S-SEAT BELT	1				
26	2720975-07	SPACER-NYLON 3/8"	2				
27	2720975-09	SPACER-NYLON 1/4"	2				

\* NOT ILLUSTRATED

FIGURE 12

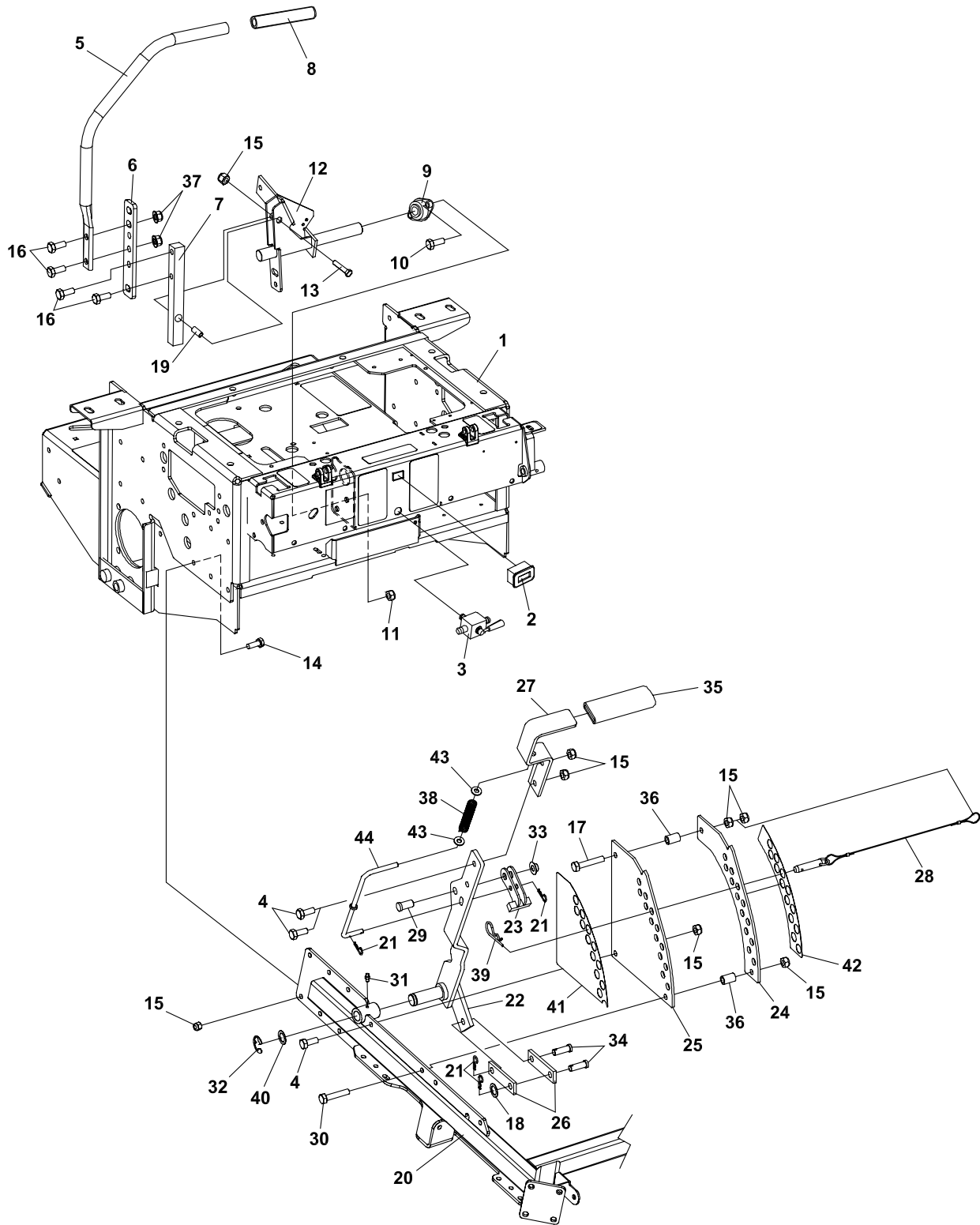

# PREDATOR-PRO SERIES

# STEERING/DECK LIFT

## FIGURE 12

ITM	PART NO.	DESCRIPTION	QTY	ITM	PART NO.	DESCRIPTION	QTY
1	4136780	S ENGINE DECK W/LABS	1				
2	4136792	METER-HOUR	1				
3	2188161	VALVE-TANK SELECTOR	1				
4	A1104057	BOLT-M10-1.50X25	3				
5	4122172.7	LEVER-TRACTION CNTRL	2				
6	4122173.7	BRKT-TRACTION LEVER	2				
7	2183074	BRKT-HANDLE	2				
8	4144705	GRIP-HANDLE	2				
9	2188145	BEARING-.75ID SELF ALIGN	4				
10	64123-15	BOLT-3/8-16X3/4 HEX	8				
11	64141-4	NUT-WLF 3/8-16	8				
12	4112105.7	WLDMT-MTN CONTRL RH	1				
	*4112104.7	WLDMT-MTN CONTRL LH	1				
13	64205-011	BLT-MET M10-1.50X40	2				
14	A110406	SCREW,M10X1.5X30 HH	12				
15	64237-03	LOCKNUT-NYLON M10-1.5	20				
16	64263-013	BLT-FLG HD M10-1.5 X 30	8				
17	64205-008	BLT-MET M10-1.50X55	1				
18	64163-43	WSHR.443/.454X1X11GA	1				
19	2183073	SPACER	2				
20	4159920.7	WLDMT-CRADLE	1				
21	64168-2	COTTER-HAIRPIN.08X1.19	4				
22	2720551.7	WLDMT-DECK LIFT LEVER	1				
23	2720511.7	WLDMT-LVR STOP LATCH	1				
24	2720517.7	BRKT-INNER DECK LIFT	1				
25	2720516.7	BRKT-OUTER DECK LIFT	1				
26	4116590.7	BRACKET-LIFT LINK	2				
27	2720501.7	HANDLE-LIFT ARM	1				
28	4159060	ASSY, PIN & LANYARD	1				
29	64188-53	PIN-CLEVIS 1/2X1.0	1				
30	64205-052	BLT-MET M10-1.5X50	1				
31	85010N	ZERK, 1/4-28 STR SELF TH	1				
32	64221-04	E-RING .875	1				
33	64175-05	NUT-PUSH 1/2	1				
34	64188-36	PIN, CLEVIS 7/16X1-1/4	2				
35	2188143	GRIP	1				
36	2183071-03	SPACER-15.88X10.32X24	2				
37	64265-05	NUT-FL NYL LOCK M10-1.5	4				
38	2720544	SPRING-COMPRESSION	1				
39	64168-1	COTTER-HAIRPIN.12X2-3/8	1				
40	64163-65	WSHR .890X1.375X18GA	3				
41	2720742	LBL-ZT200 HT CUT OUTER	1				
42	2720743	LBL-ZT200 HT CUT INNER	1				
43	64163-29	WASHER-21/64 X 1 X 11GA	2				
44	4159284	ROD-LIFT STOP	1				

\* NOT ILLUSTRATED

# CRADLE ASSEMBLY

# PREDATOR-PRO SERIES

FIGURE 13

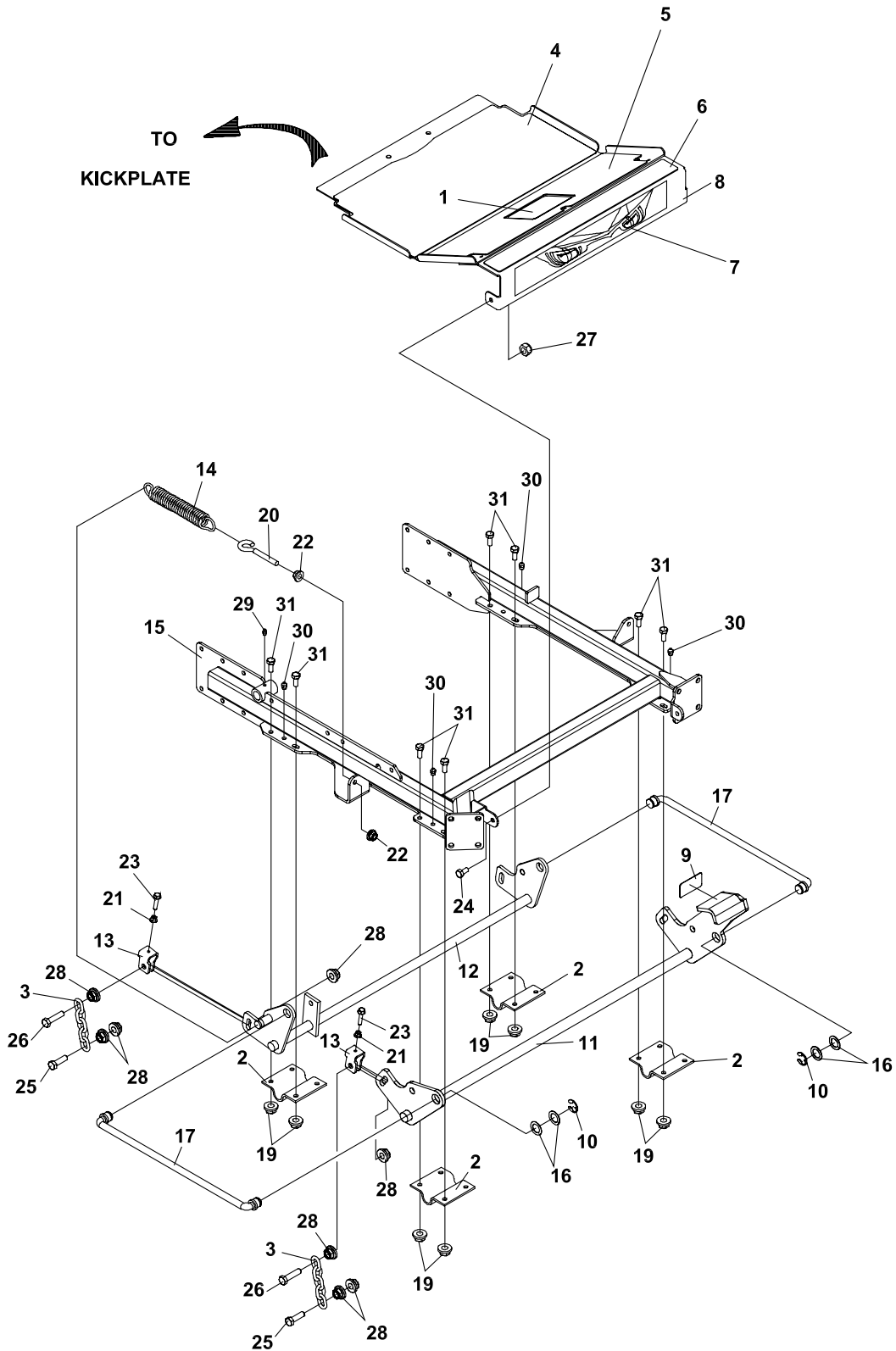



# PREDATOR-PRO SERIES

# CRADLE ASSEMBLY

## FIGURE 13

ITM	PART NO.	DESCRIPTION	QTY	ITM	PART NO.	DESCRIPTION	QTY
1	4118843	LBL - WARN/USING	1				
2	2182356.7	BRACKET-SHAFT HANGER	4				
3	2188127	CHAIN-6.35 (.250) 5 LINKS	4				
	2722454	CHAIN-6.35 (1/4) 3 LINKS	2				
	(USED ON 72" MODEL ONLY)						
4	2721859	MAT-FOOT PLATE LOWER	1				
5	4129955	MAT-FOOT PLATE MIDDLE	1				
6	2721861	MAT-FOOT PLATE UPPER	1				
7	4143966	LABEL-PREDATOR EYES	1				
8	4144111	S-FOOT PLATE	1				
	(INCLUDES 4-7, 9 & 16)						
9	4139785	MAT-FOOT LIFT	1				
10	64221-04	E-RING.875	4				
11	4159283.7	WLDMT-DECK LIFT, FRONT	1				
12	2722559.7	WLDMT-DECK LIFT, REAR	1				
13	2722630	CLIP-DECK HEIGHT ADJ	4				
14	2722719	SPRING-DECK LIFT	2				
15	4159920.7	WLDMT-CRADLE	1				
16	64163-65	WASHER-.890X1.375X18GA	8				
17	4109960	WLDMT-DECK LIFT ROD	2				
18*	4111842.7	BRKT-SPRING ANCHOR LH	1				
19	64265-05	NUT-FL NYLN LCK M10-1.5	15				
20	4113682	ROD-SPRING MOUNT	2				
21	64141-2	NUT-WLF 1/4-20	4				
22	64141-4	NUT-WLF 3/8-16	4				
23	64197-020	BLT-TDFM 1/4-20X1-1/2	4				
24	64205-007	BLT MET M10-1.50X20	2				
25	64205-029	BLT-MET M12X1.75X40	4				
26	64205-060	BOLT-MET M12-1.75X50	4				
27	64237-03	LOCKNUT-NYLON M10-1.5	2				
28	64246-04	NUT-WHIZ M12-1.75	16				
29	85010N	ZERK, 1/4-28 STR SLFTHRD	1				
30	85051	ZERK-1/8 PIPE	6				
31	64263-013	BLT-FLG HD M10-1.5 X 30	15				

**\*NOT ILLUSTRATED**

# CRADLE & CASTER ASSEMBLY

# PREDATOR-PRO SERIES

FIGURE 14

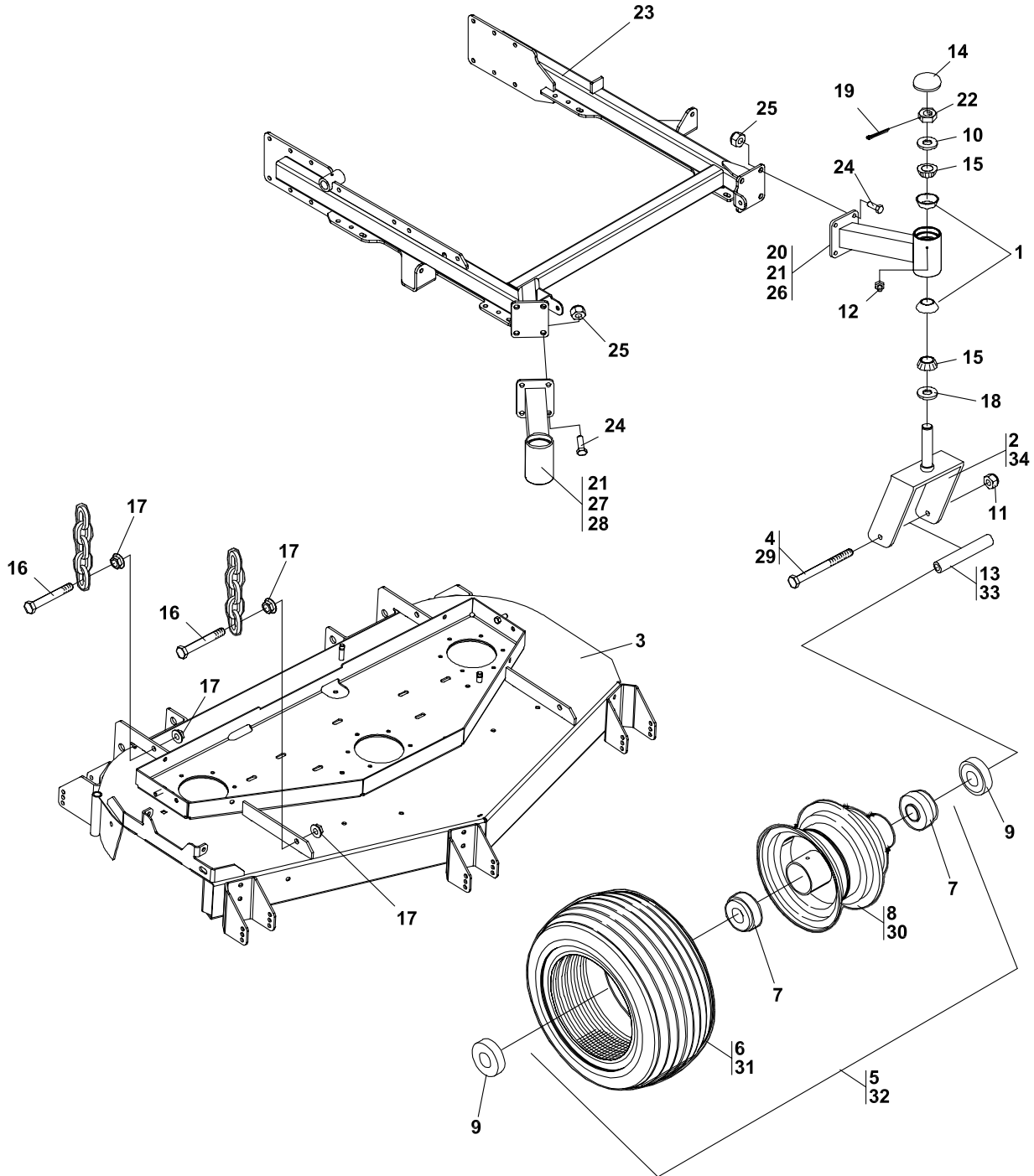

# PREDATOR-PRO SERIES

# CRADLE & CASTER ASSEMBLY

## FIGURE 14

ITM	PART NO.	DESCRIPTION	QTY	ITM	PART NO.	DESCRIPTION	QTY
1	48043-03C	CUP, OUTER BEARING	4	28	4113902.7	WLDMT-CASTER ARM 61RH1 (ITEMS 21 & 28 USED WITH 61" DECKS)	
2	2721306.7	WLDMT-CASTER YOKE	2				
3		DECK/W LABS					
4	64123-215	BOLT-HEX 3/4-10X7 1/2	2	29	64123-223	BOLT-3/4-10 X 10	2
5	2722228	WHEEL-13X5.00-6 ASSY (INCLUDES ITEMS 6-8) (USED ON 52" ONLY)	2	30	2722326-02	RIM ASM-W/VALVE STEM	2
				31	2722326-01	TIRE-13X6.50-6 SMTH TRD	2
				32	2722326	ASSY-WHL 13X6.5-6 SMOOTH 2 (INCLUDES ITEMS 7, 31 & 32)	2
6	2720475-01	TIRE-13X5.00-6 SMOOTH (USED ON 52" ONLY)	1				
				33	2722230-03	SPANNER-13X6.5 WHEEL	2
				34	2722452.7	WLDMT-CASTER YOKE (ITEMS 29-34 USED ON 61" & 72" DECKS)	2
7	2722228-03	BEARING	2				
8	2722228-01	RIM-13"ASSY W/VALVE (USED ON 52" ONLY)	1				
9	2722231	SPACER-END	4				
10	64163-64	WSHR 1.015X1.500X14GA	2				
11	64229-07	LOCKNUT-NYLON 3/4-10	2				
12	85010N	ZERK, 1/4-28 STR SLF THD	2				
13	2722230-02	SPANNER-13" WHEEL (USED ON 52" ONLY)	2				
14	2188135	DUST COVER	2				
15	48043-04C	CONE, OUTER BEARING	4				
16	64205-029	BLT-MET M12X1.75X40	4				
17	64246-04	NUT-WHIZ M12-1.75	8				
18	48480	SEAL CR 12411	2				
19	64140-5	COTTER PIN	2				
20	2722399.7	WLDMT-CASTER ARM 52LH (ITEM 20 USED WITH 52" DECKS)	1				
21	2722398.7	WLDMT-CASTER ARM 52/61	1				
22	64025-20	NUT-HEX 3/4-16 SLOT U	2				
23	4159920.7	WLDMT-CRADLE	1				
24	A1105061	BOLT-M12-1.75X30	8				
25	64237-06	LOCKNUT-NYLON M12-1.75	8				
26	2722431.7	WLDMT-CASTER ARM 72LH	1				
27	2722432.7	WLDMT-CASTER ARM 72RH (ITEMS 26 & 27 USED WITH 72" DECKS)	1				

# 52" SIDE DISCHARGE

# PREDATOR-PRO SERIES

## FIGURE 15

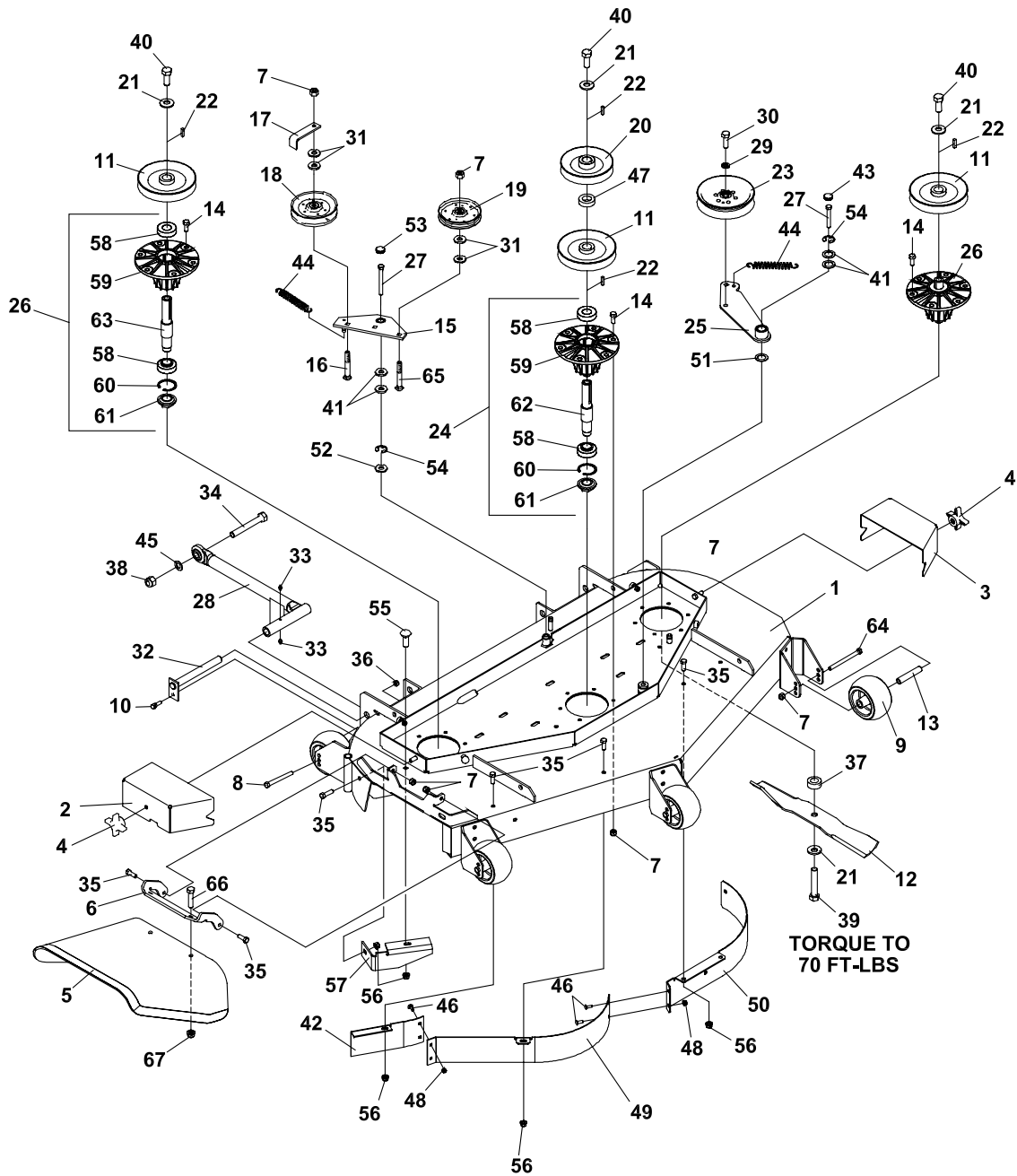

# PREDATOR-PRO SERIES

# 52" SIDE DISCHARGE

## FIGURE 15

ITM	PART NO.	DESCRIPTION	QTY	ITM	PART NO.	DESCRIPTION	QTY
1	4131501	S-52" DECK	1	42	4134343.7	BAFFLE-RIGHT FRONT 52-54	1
2	2722574.2	COVER-BELT RH	1	43	4128002	CAP-26 X 7, END	1
3	2722575.2	COVER-BELT LH	1	44	2188131	SPRING-EXTENSION	2
4	38524	KNOB-4 PRONG 3/8-16	2	45	64163-73	WSHR-.625IDX1.12ODX.06	A/R
5	4147115	CHUTE-RUBBER ASSY 32-54	1	46	64018-2	BLT-CRG 1/4-20X3/4	4
6	4149017.7	HINGE-CHUTE_RUBBER	1	47	64163-64	WSHR 1.015X1.500X14	1
7	64229-03	LOCKNUT NYLON 3/8-16	32	48	64229-01	LOCKNUT-1/4-20	2
8	64123-173	BLT-HEX 3/8-16X4-1/2	2	49	4134338.7	BAFFLE-FRONT RH	1
9	2721512	ROLLER-5X2.75 CENTERED	6	50	4118427.7	BAFFLE-FRONT LH	1
10	64123-68	BOLT-HEX 5/16-18X1	2	51	4127999	SEAL	1
11	2308140	PULLEY ENGINE	3	52	4128000	SEAL	1
12	112111-02	BLADE 18.00 OFFST HLFT	3	53	4128001	END CAP	1
13	2720685	SPACER-ROLLER	6	54	64144-40	SNAP RING	2
14	64262-012	BLT-FLG HD 3/8-16 X 1-1/4	18	55	64018-3	BOLT-3/8-16X1 CARRIAGE	1
15	4129074	ASSY-IDLER ARM PTO (INCLUDES ITEMS 41, 52 & 54)	1	56	64229-01	NUT-FL NYLN LOCK 3/8-16	6
16	64018-18	BOLT-CARRIAGE 3/8-16X2	1	57	4115864.7	BAFFLE-DISCHARGE	1
17	2302125.7	GUIDE-BELT	1	58	38348-01	BEARING-SPINDLE SEALED	6
18	48393	PULLEY, V IDLER	1	59	2721096	HOUSING-SPINDLE 6 HOLE	3
19	38297	IDLER, 5.0 OD FLNGD	1	60	64144-38	SNAP RING	3
20	2228034	PULLEY-5.25 DEEP GRV	1	61	38315	NUT-SPINDLE	3
21	64209-03	SPRING WSHR .67 ID	6	62	2183070-01	SHAFT-SPINDLE LONG (USED ON 4115849 CENTER SPINDLE ONLY)	1
22	64164-12	1/4X1/4X1 SQ END KEY	4	63	2183070-02	SHAFT-SPINDLE (USED ON 4115850 OUTER SPINDLE ONLY)	2
23	128169	PULLEY, IDLER 5.50	1	64	64018-30	BOLT-CRG 3/8-16 X 4-1/2	3
24	4115849	S-ASSYSPNDL ZT200 CNTR (INCLUDES ITEMS 58-62)	1	65	64018-5	BLT-CRG 3/8-16X1-3/4	1
25	4129075	ASSY-DECK IDLER (INCLUDES ITEMS 41,42, 51 & 54)	1	66	64262-013	BLT-FLG HD 3/8-16 X 1-1/2	2
26	4115850	S-ASSYSPNDL ZT200 OUTR (INCLUDES ITEMS 58-61 & 63)	2	67	64268-03	NUT-FL NYLON LOCK 3/8-16	2
27	64270-01	BOLT, 3/8-16X2-3/4 HEX	2	68*	64123-217	BLT-HEX 3/8-16X4-1/4 CTR	1
28	4133155.7	WLDMT-PUSHBAR	2				
29	64006-05	LOCKWSHR-HELICAL 1/2	1				
30	64123-05	BLT-HEX 1/2-20X1-1/2	1				
31	64163-46	WASHER.383/.393X.88X7	4				
32	2186125	WLDMT-LOCK, PUSHBAR	2				
33	85010N	ZERK, 1/4-28 STR SLF THD	4				
34	64123-152	BLT-HEX 5/8-16X4-1/4	2				
35	64123-50	BOLT-HEX 3/8-16X1	9				
36	64229-02	LOCKNUT-NYLON 5/16-18	2				
37	4118314	SPACER-BLADE 16MM	3				
38	64229-06	LOCKNUT, NYLON 5/8-11	2				
39	64123-187	BLT-HEX 5/8-18X3.75	3				
40	64123-208	BLT-HEX 5/8-18X1.5	3				
41	4128004	BEARING	4				

\* NOT ILLUSTRATED

# 61" SIDE DISCHARGE

# PREDATOR-PRO SERIES

## FIGURE 16

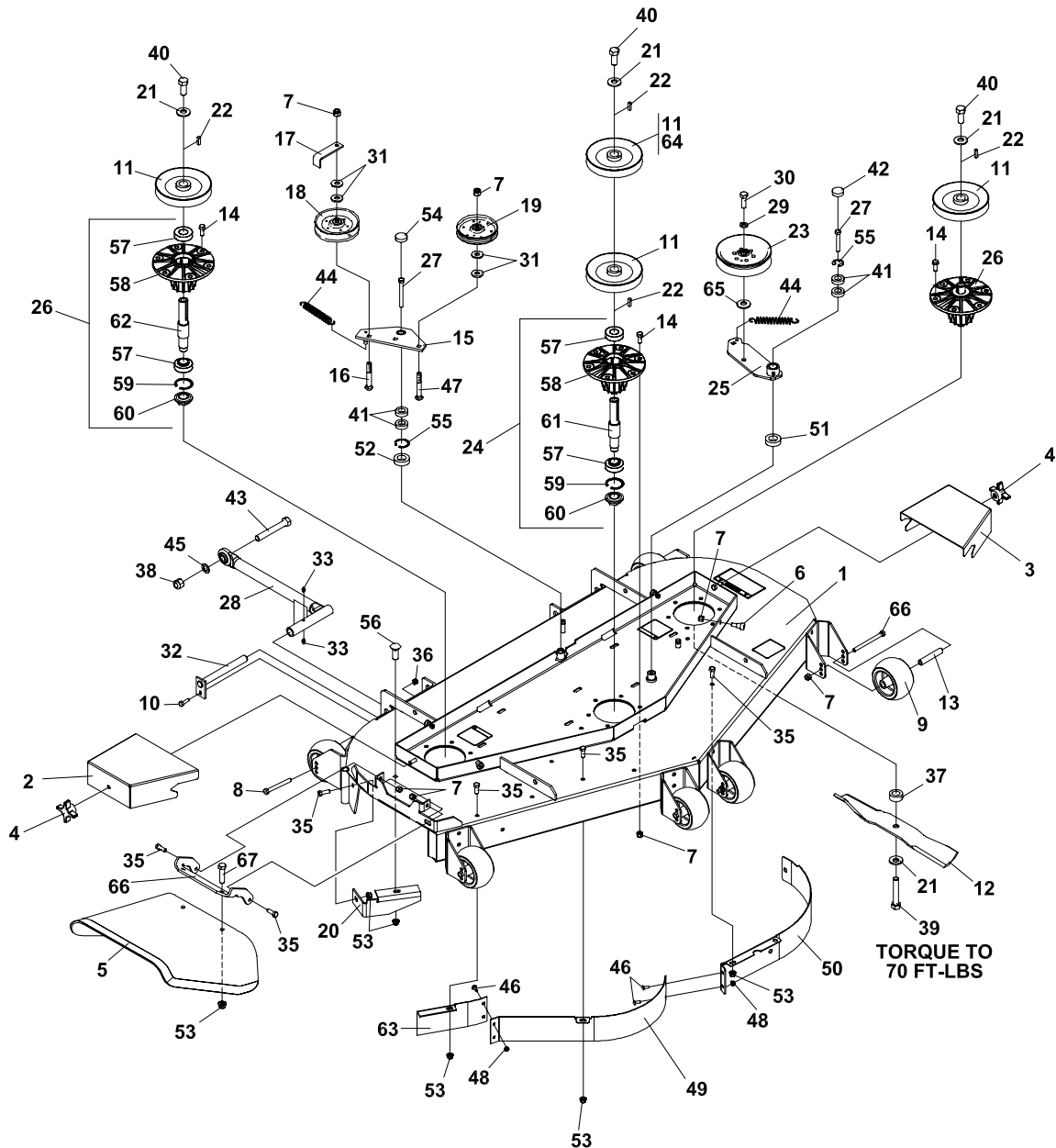

# PREDATOR-PRO SERIES

# 61" SIDE DISCHARGE

## FIGURE 16

ITM	PART NO.	DESCRIPTION	QTY	ITM	PART NO.	DESCRIPTION	QTY
1	4131517	S-61" DECK	1	39	64123-187	BLT-HEX 5/8-18X3.75	3
2	2182352.2	BELT COVER RH	1	40	64123-208	BLT-HEX 5/8-18X1.5	3
3	2182351.2	BELT COVER LH	1	41	4128004	BEARING	4
4	38524	KNOB-4 PRONG 3/8-16	2	42	4128002	END CAP	1
5	4147115	CHUTE-RUBBER ASSY	1	43	64123-152	BLT-HEX 5/8-11X 5	2
6	64166-17	BLT-SHLDR 3/8-16X1.12	4	44	2188131	SPRING-EXTENSION	2
7	64229-03	LOCKNUT NYLON 3/8-16	35	45	64163-73	WSHR-.625IDX1.12ODX.06	A/R
8	64123-173	BLT-HEX 3/8-16X4-1/2	2	46	64018-2	BLT-CRG 1/4-20X3/4	4
9	2721512	ROLLER-5X2.75 CENTERED	7	47	64018-5	BLT-CRG 3/8-16X1-3/4	1
10	64123-68	BOLT, 5/16-18 X 1 HEX	2	48	64229-01	LOCKNUT-1/4-20	4
11	2308140	PULLEY ENGINE		49	4134340.7	BAFFLE-FRONT CENTER	1
		(QTY 3 USED ON 33HP GENERAC MODELS)		50	4117663.7	BAFFLE-FRONT LH	1
		(QTY 4 USED ON KAWASAKI MODEL)		51	4127999	SEAL	1
				52	4128000	SEAL	1
12	112111-03	BLADE 21.00 OFFST HLFT	3	53	64268-03	NUT-FL NYL N LOCK 3/8-16	10
13	2720685	SPACER-ROLLER	7	54	4128001	END CAP	1
14	64262-012	BLT-FLG HD 3/8-16 X 1-1/4	18	55	64144-40	SNAP RING	2
15	4129074	ASSY-IDLER ARM PTO	1	56	64018-3	BOLT-3/8-16X1 CARRIAGE	1
		(INCLUDES ITEMS 41, 52, 54 & 55)		57	38348-01	BEARING-SPINDLE SEALED	6
				58	2721096	HOUSING-SPINDLE 6 HOLE	3
16	64018-18	BOLT-CARRIAGE 3/8-16X2	1	59	64144-38	SNAP RING	3
17	2302125.7	GUIDE-BELT	1	60	38315	NUT-SPINDLE	3
18	48393	PULLEY, V IDLER	1	61	2183070-01	SHAFT-SPINDLE LONG	1
19	38297	IDLER, 5.0 OD FLNGD	1			(USED ON 4115849 CENTER SPINDLE ONLY)	
20	4115864.7	BAFFLE-DISCHARGE	1				
21	64209-03	SPRING WSHR .67 ID	6	62	2183070-02	SHAFT-SPINDLE	2
22	64164-12	1/4X1/4X1 SQ END KEY	4			(USED ON 4115850 OUTER SPINDLE ONLY)	
23	128169	PULLEY, IDLER 5.50	1				
24	4115849	S-ASSYSPNDL ZT200 CNTR	1	63	4134344.7	BAFFLE-RIGHT FRONT 61	1
		(INCLUDES ITEMS 57-61)		64	4130120	PULLEY	1
						(USED ON 33HP GENERAC MODELS)	
25	4129076	ASSY-DECK IDLER 61"	1				
		(INCLUDES ITEMS 41, 51, 54 & 63)		65	64163-36	WASHER	1
				66	4149017.7	HINGE-CHUTE RUBBER	1
26	4115850	S-ASSYSPNDL ZT200 OUT	2	67	64262-013	BLT-FLG HD 3/8-16 X 1-1/2	2
		(INCLUDES ITEMS 57-60 & 62)					
27	64270-01	BOLT-M10-1.5 X 30	2				
28	4133155.7	WLDMT-PUSHBAR	2				
29	64006-05	LOCKWSHR-HELICAL 1/2	1				
30	64123-05	BLT-HEX 1/2-20X1-1/2	1				
31	64163-46	WSHR.383/.393X.88X7	4				
32	2186125	WLDMT-LOCK, PUSHBAR	2				
33	85010N	ZERK, 1/4-28 STR SLF THD	4				
34	64123-217	BLT-HEX 3/8-16X4-1/4	5				
35	64123-50	BOLT-HEX 3/8-16X1	9				
36	64229-02	LOCKNUT-NYLON 5/16-18	2				
37	4118314	SPACER-BLADE 16MM	3				
38	64229-06	LOCKNUT, NYLON 5/8-11	2				



# 72" SIDE DISCHARGE

# PREDATOR-PRO SERIES

## FIGURE 17

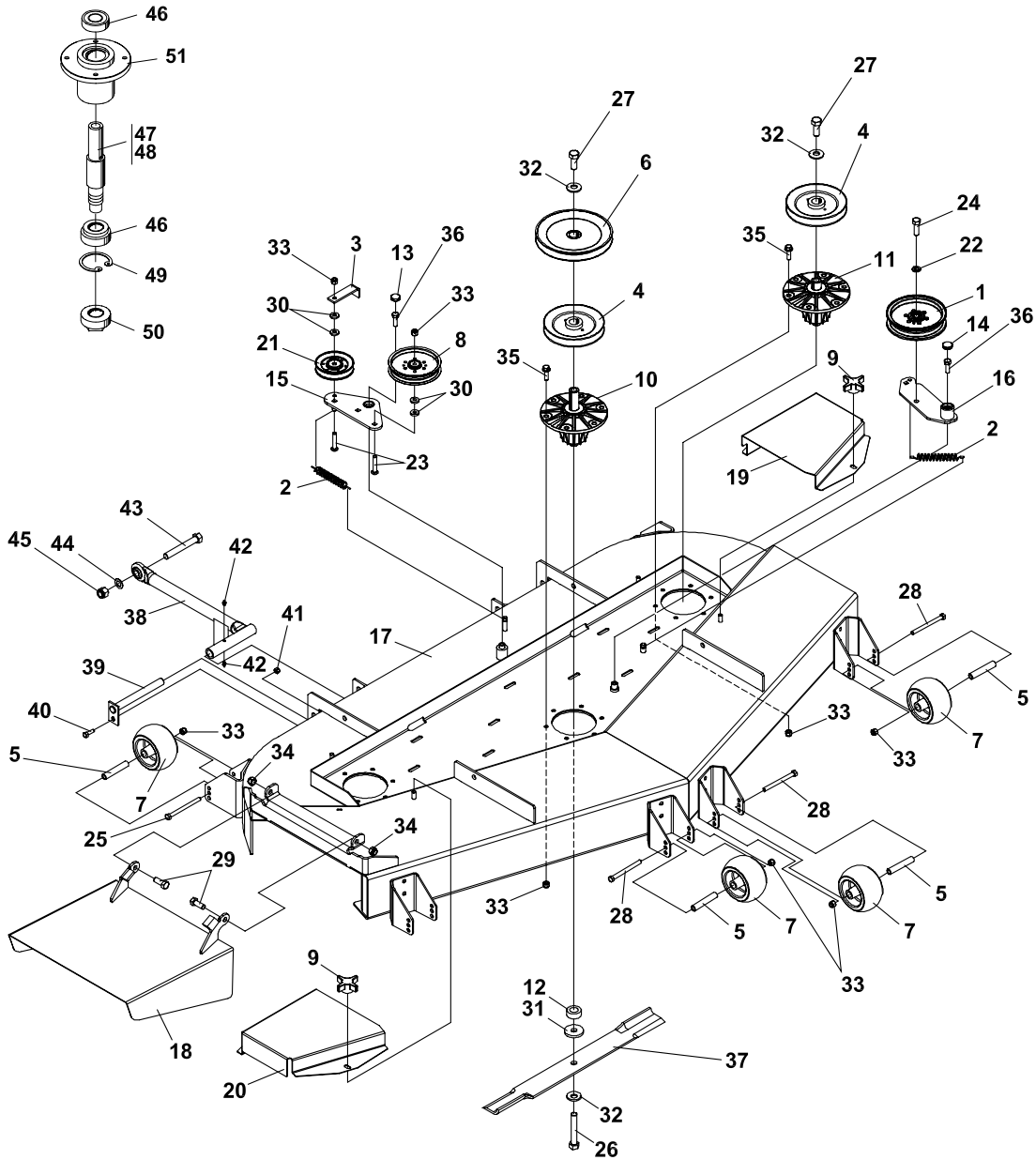

# PREDATOR-PRO SERIES

# 72" SIDE DISCHARGE

## FIGURE 17

ITM	PART NO.	DESCRIPTION	QTY	ITM	PART NO.	DESCRIPTION	QTY
1	128169	PULLEY-IDLER	1	37	3970261	BLADE-HIGH LIFT	3
2	2188131	SPRING-EXTENSION	2	38	4133155.7	WLDMT-PUSH ARM	2
3	2302125.7	GUIDE-BELT	1	39	2186125	WLDMT-LOCK, PUSHBAR	2
4	2308140	PULLEY-ENGINE	3	40	64123-68	BOLT-HEX 5/16-18X1	2
5	2720685	SPACER-ROLLER	7	41	64229-02	LOCKNUT-5/16-18	2
6	2721415	PULLEY	1	42	85010N	ZERK-1/4-28	4
7	2721512	ROLLER	7	43	64123-152	BLT-HEX 5/8-11 X 5	2
8	38297	IDLER	1	44	64163-73	WASHER	2
9	38524	KNOB-4 PRONG	4	45	64229-06	LOCKNUT-5/8-11	2
10	4115849	S-ASSY SPINDLE CENTER	1	46	38348-01	BEARING	6
11	4115850	S-ASSY SPINDLE OUTER	2	47	2183070-01	SHAFT-SPINDLE LONG	1
12	4118314	SPACER-BLADE	3	48	2183070-02	SHAFT-SPINDLE	2
13	4128001	END CAP	1	49	64144-38	SNAP RING	3
14	4128002	END CAP	1	50	38315	NUT-SPINDLE	3
15	4129074	ASSY-IDLER ARM PTO	1	51	2721096	HOUSING-SPINDLE 6 HOLE	3
	4128004	BEARING	2				
	64144-40	SNAP RING	1				
	4128000	SEAL	1				
16	4129076	ASSY-DECK IDLER 61"	1				
	4127999	SEAL	1				
	4128004	BEARING	2				
	64144-40	SNAP RING	1				
17	4136784	S-CUTTERDECK	1				
18	4131902.2	WLDMT-CHUTE 72 SD	1				
19	4131945.2	GUARD-BELT LH	1				
20	4131946.2	GUARD-BELT RH	1				
21	48393	PULLEY-V IDLER	1				
22	64006-05	LOCKWASHER-1/2	1				
23	64018-18	BOLT-CRG 3/8-16 X 2	2				
24	64123-05	BLT-HEX 1/2-20X1-1/2	1				
25	64123-173	BLT-HEX 3/8-16X4-1/2	2				
26	64123-187	BLT-HEX 5/8-18 X 3 3/4	3				
27	64123-208	BLT-HEX 5/8-18X1.5	3				
28	64123-217	BLT-HEX 3/8-16X4-1/4	5				
29	64123-39	BOLT-HEX 1/2-13X1-1/4	2				
30	64163-46	WASHER	4				
31	64163-78	WASHER	3				
32	64209-03	SPRING WASHER	6				
33	64229-03	LOCKNUT-3/8-16	27				
34	64229-05	LOCKNUT-1/2-13	2				
35	64262-012	BLT-FLG HD 3/8-16 X 1-1/4	18				
36	64270-01	BOLT-MET M10-1.5x30	2				

**FIGURE 18**

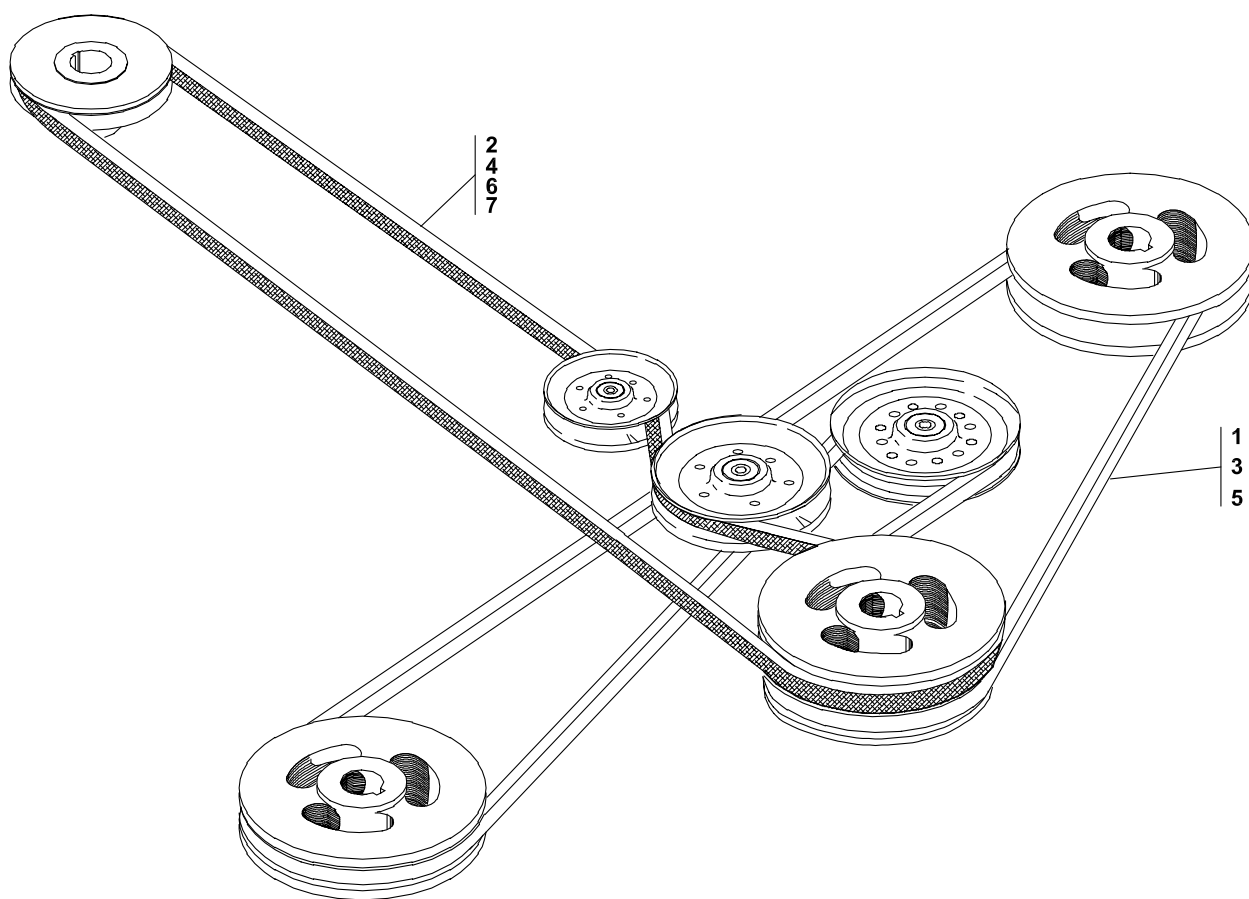

# PREDATOR-PRO SERIES

# BELTS-CUTTERDECK

FIGURE 18

ITM	PART NO.	DESCRIPTION	QTY	ITM	PART NO.	DESCRIPTION	QTY
1	2188176	BELT-CUTTERDECK 54	1				
2	2720815	BELT-PTO 54 (USE ON 52" SD DECK)	1				
3	128003	BELT-CUTTERDECK 61	1				
4	2722224	BELT-PTO 61 (USE ON 61" SD DECK)	1				
5	4135683	BELT-CUTTERDECK 72	1				
6	2722554	BELT-PTO 72 (USE ON 72" SD DECK)	1				
7	2720881	BELT-61 DECK DRIVE (USED ON MODEL 942245E ONLY)	1				

FIGURE 19

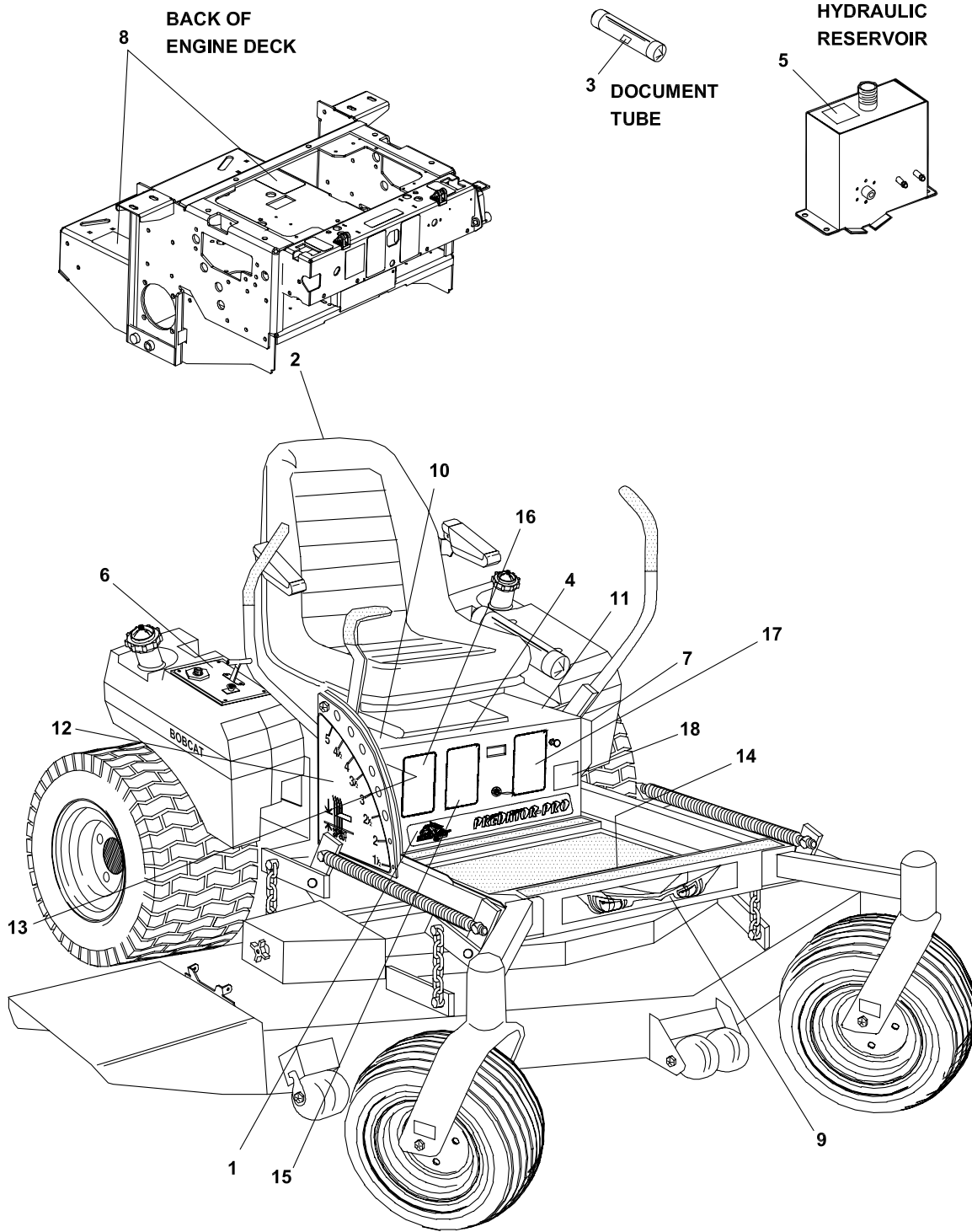

# PREDATOR-PRO SERIES

# DECALS-POWER UNIT

FIGURE 19

ITM	PART NO.	DESCRIPTION	QTY	ITM	PART NO.	DESCRIPTION	QTY
1	4157862	LABEL- PREDATOR PRO	1				
2	4158401	LABEL-BOBCAT PRED PRO	1				
3	2000735	LABEL-OPER MAN	1				
4	2000590	LABEL-WARN BATTERY	1				
5	2000691	LABEL-HYDR OIL FILL	1				
6	4124415	LABEL-CNTRL PNL ZT200	1				
7	2000693	LABEL-PARK BRAKE	1				
8	2000698	LABEL-FUEL/LEAKS	2				
9	4143966	LABEL-BOBCAT EYES	1				
10	2000700	LABEL-RH TRACTION	1				
11	2000701	LABEL-LH TRACTION	1				
12	2720742	LABEL-HT CUT OUTER	1				
13	2720743	LABEL-HT CUT INNER	1				
14	4118843	LABEL-WARNING	1				
15	2000706	LABEL-FUEL	1				
16	340830	LABEL-CAUTION SPANISH	1				
17	4114158	LABEL-TIRES	1				
18	4116761	LABEL-MADE IN USA	1				

FIGURE 20

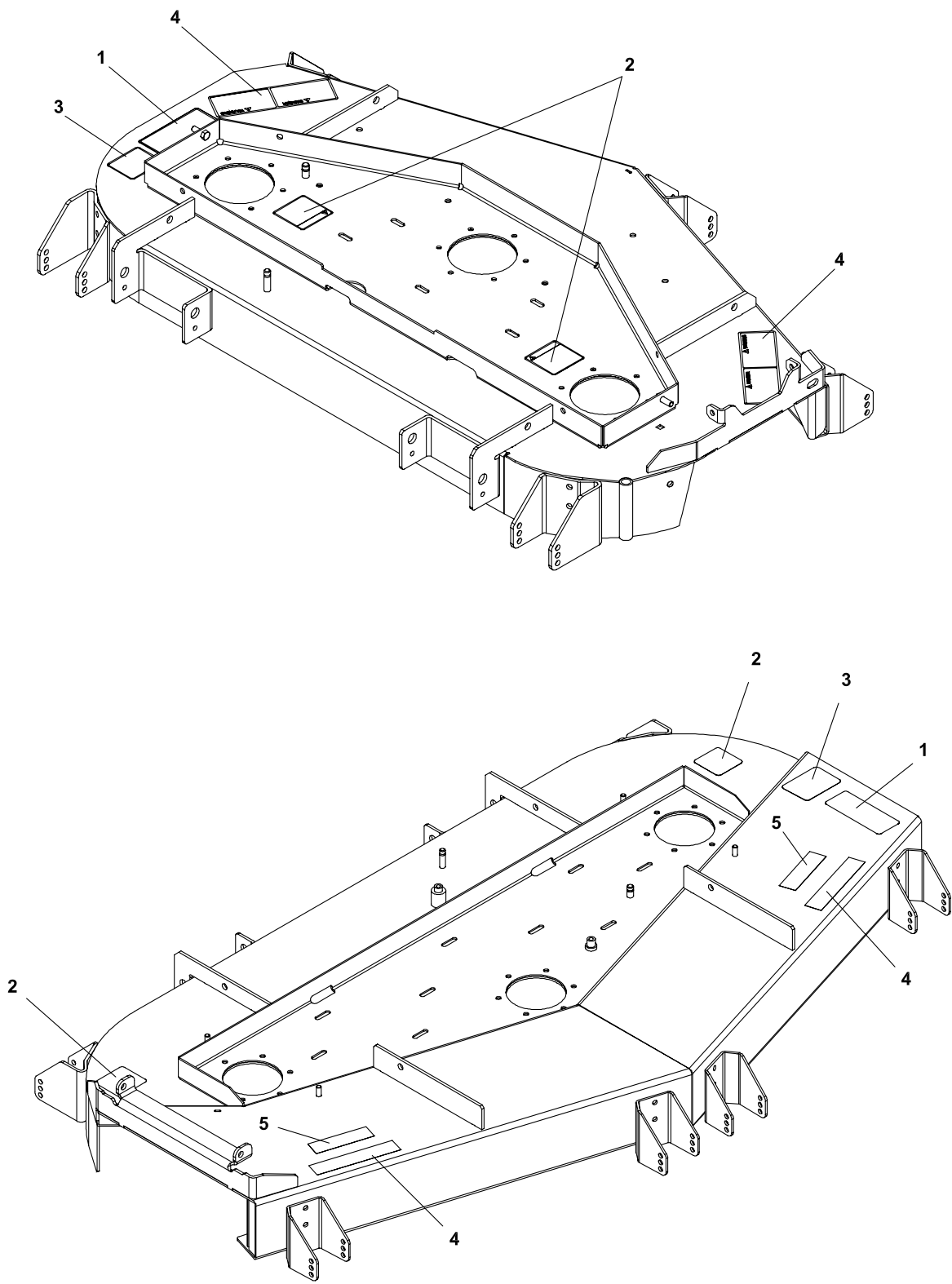



# PREDATOR-PRO SERIES

# DECALS-CUTTERDECKS

FIGURE 20

ITM	PART NO.	DESCRIPTION	QTY	ITM	PART NO.	DESCRIPTION	QTY
1	2000572	LABEL-WARNING BLADES	1				
2	2000577	LABEL-WARNING	2				
3	2000696	LABEL-BLADE INSTALL	1				
4	2000677	LABEL-DANGER/WARNING	2				
5	2000787	DECAL-NO STEP (USED ON 72" DECKS ONLY)	2				

FIGURE 21

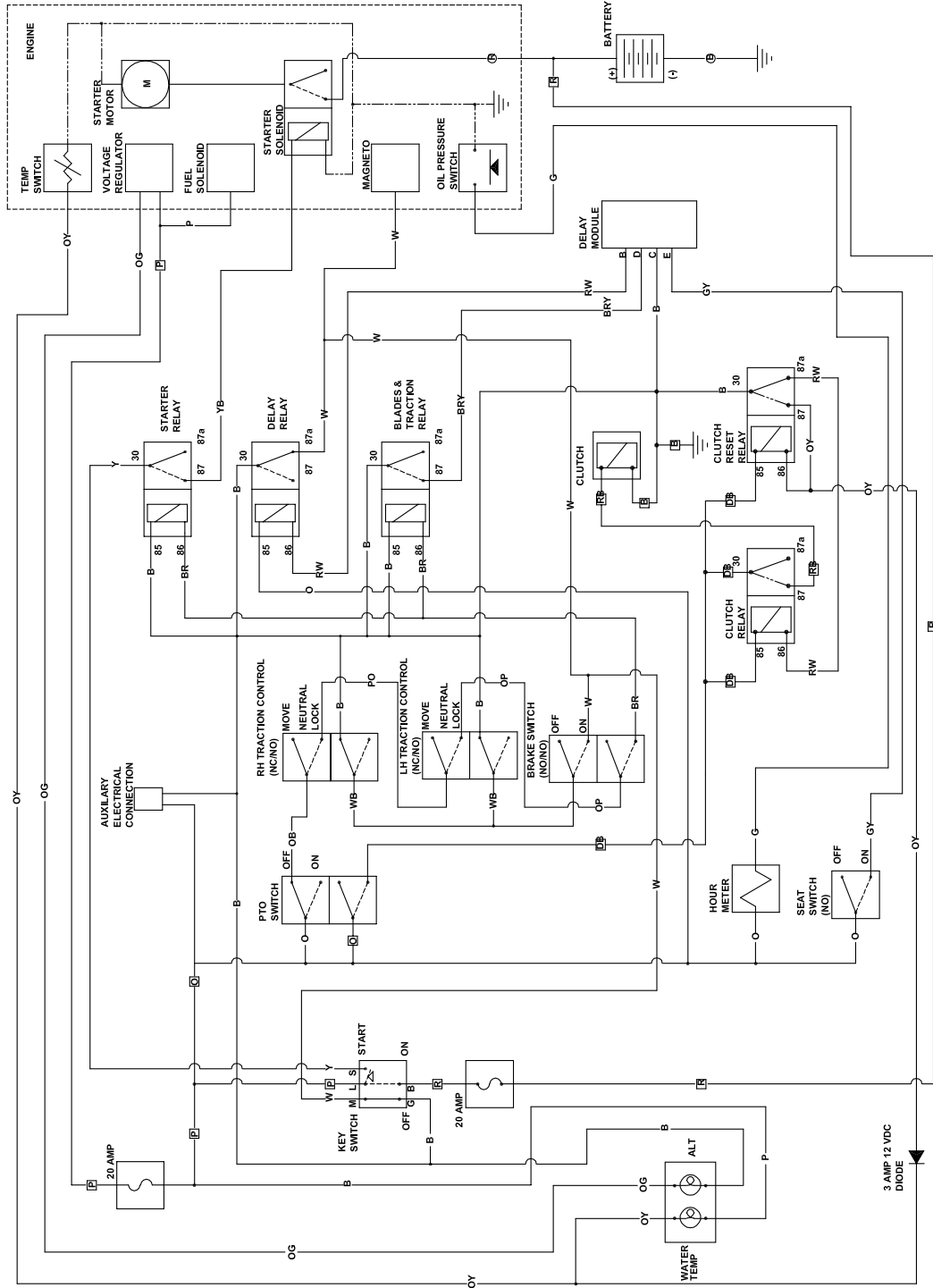

## World Class Quality, Performance And Support



Equipment from Commercial Grounds Care, Inc. is built to exacting standards ensured by ISO 9001 and ISO 14001 registration at all our manufacturing locations.

A worldwide dealer network and factory-trained technicians provide reliable, high-quality product support.



---

*BOB-CAT BUNTON RYAN STEINER*